

**STEGE SANITARY DISTRICT
CONTRA COSTA COUNTY
CALIFORNIA**

PROJECT SPECIFICATIONS



STANDARD SEWER REHABILITATION PROJECT

**PROJECT NO. 12201
JULY 2012**

STEGE SANITARY DISTRICT
7500 SCHMIDT LANE
EL CERRITO, CA 94530

510-524-4668
510-524-4667 FAX
www.stegesd.dst.ca.us

(This page left blank intentionally)

PART I

BID DOCUMENTS

STEGE SANITARY DISTRICT
PROJECT NO. 12201
JULY 2012

**STEGE SANITARY DISTRICT
PROJECT NO. 12201 – JULY 2012
TABLE OF CONTENTS**

PART I	BID DOCUMENTS	<u>WHITE</u>
	Notice to Contractors	NC.1
	Instruction to Bidders	IB.1
	BID PROPOSAL	<u>BLUE</u>
	Bid Proposal	BP.1
	Bid Schedule	BP.3
	List of Subcontractors	BP.9
	Receipt of Addenda	BP.10
	Bidder's Experience Statement	BP.11
	Personnel Experience Statement	BP.12
	Contractor's License Statement	BP.13
	Non-Collusion Affidavit	BP.14
	Security for Compensation Certificate	BP.15
	Bid Bond	BP.17
	Contractor's/Subcontractor's Certification Concerning State Labor Standards and Prevailing Wages	BP.19
	Nondiscrimination Clause	BP.20
	Safety Program Qualification Criteria Experience Modification Rate (EMR or Exmod)	BP.23
	Safety Program Qualification Criteria Recordable Incident Rate (RIR)	BP.24
	Safety Program Qualification Criteria Lost Time Incident Rate (LTIR)	BP.25
	Bond of Faithful Performance	BP.27
	Labor and Material Bond	BP.29
	Agreement	BP.31
PART II	GENERAL CONDITIONS	<u>WHITE</u>
Section 1	Definition and Terms	GC.1
	G1.01 General	GC.1
	G1.02 Definitions	GC.1
	G1.03 Abbreviations	GC.3
Section 2	Proposal Requirements	GC.5
	G2.01 Obtaining Proposal Forms	GC.5
	G2.02 Engineer's Estimate	GC.5
	G2.03 Examination of Contract Documents and Site of Work	GC.5
	G2.04 Surface Topography; Subsurface Conditions Data	GC.5
	G2.05 Explanations	GC.5
	G2.06 Preparation of Proposals	GC.5
	G2.07 Submission of Proposals	GC.6

	G2.08 List of Subcontractors	GC.6
	G2.09 Proposal Guaranty	GC.6
	G2.10 Withdrawal of Proposals	GC.6
	G2.11 Public Opening of Proposals	GC.6
	G2.12 Rejection of Proposals	GC.6
	G2.13 Licensing of Bidders	GC.7
	G2.14 Engineer of Work	GC.7
Section 3	Award and Execution of Contract	GC.9
	G3.01 Award of Contract	GC.9
	G3.02 Time of Award	GC.9
	G3.03 Execution of Contract	GC.9
	G3.04 Contract Bonds	GC.9
	G3.05 Failure to Execute Contract	GC.9
	G3.06 Return of Proposal Guaranty	GC.10
Section 4	Scope of Work	GC.11
	G4.01 Intent of Contract Documents	GC.11
	G4.02 Examination and Verification of Contract Documents	GC.11
	G4.03 Changes; Contract Change Order	GC.11
	G4.04 Request for Quotations for Change in Work	GC.12
	G4.05 Proposed Contract Change Order	GC.12
	G4.06 Executed Contract Change Order	GC.12
	G4.07 Contract Price Adjustment	GC.12
	G4.08 Protest Procedure	GC.13
	G4.09 Continuance of Construction	GC.13
	G4.10 Detours	GC.13
	G4.11 Archaeological Discoveries	GC.13
	G4.12 Preservation and Cleaning	GC.13
	G4.13 Guaranty of Work	GC.14
	G4.14 Correction of Work During Warranty Period	GC.14
Section 5	Control of Work	GC.15
	G5.01 Authority of Engineer	GC.15
	G5.02 Contract Drawings	GC.15
	G5.03 Shop Drawings	GC.15
	G5.04 Conformity with Contract Documents	GC.16
	G5.05 Coordination and Interpretation of Contract Documents	GC.16
	G5.06 Order of Work	GC.17
	G5.07 Superintendence	GC.17
	G5.08 Lines and Grades	GC.17
	G5.09 Inspection	GC.17
	G5.10 Documents on Job Site	GC.18
	G5.11 Correction, Removal of Rejected Work	GC.18
	G5.12 Equipment and Plants	GC.19
	G5.13 Character of Workers	GC.19
	G5.14 Final Inspection	GC.19
	G5.15 Submittal of As-Built Data	GC.19
	G5.16 Emergencies	GC.19
Section 6	Control of Materials	GC.21

G6.01	Source of Supply and Quality of Materials	GC.21
G6.02	Owner-Furnished Materials	GC.21
G6.03	Storage of Materials	GC.21
G6.04	Defective Materials	GC.22
G6.05	Material and Equipment Specified by Name	GC.22
G6.06	Plant Inspection	GC.22
G6.07	Product and Reference Standards	GC.22
G6.08	Samples	GC.22
G6.09	Testing of Materials or Work	GC.23
G6.10	Certificate of Compliance	GC.23
Section 7	Legal Relations and Responsibilities	GC.25
G7.01	Laws to be Observed	GC.25
G7.02	Labor Code Requirements	GC.25
G7.03	Contractors' Licensing Laws	GC.27
G7.04	Air Pollution Control	GC.27
G7.05	Water Pollution Control	GC.27
G7.06	Sound Control Requirements	GC.29
G7.07	Use of Pesticides	GC.29
G7.08	Weight Limitations	GC.29
G7.09	Payment of Taxes	GC.29
G7.10	Permits and Licenses	GC.30
G7.11	Subsurface Excavations, Notification	GC.30
G7.12	Patents	GC.30
G7.13	Safety Requirements	GC.31
G7.14	Trench Excavation Safety Plan	GC.33
G7.15	Sanitary Provisions	GC.33
G7.16	Public Convenience	GC.33
G7.17	Public Safety	GC.34
G7.18	Preservation of Property	GC.34
G7.19	Responsibility for Damage	GC.34
G7.20	Responsibility for Work and Materials	GC.35
G7.21	General Liability of Contractor	GC.35
G7.22	Prevailing Wage Indemnity and Waiver	GC.35
G7.23	Public Liability Insurance	GC.36
G7.24	Worker's Compensation Insurance	GC.37
G7.25	Property Insurance	GC.37
G7.26	Deductibles and Self-Insured Retentions	GC.37
G7.27	Evidences and Cancellation of Insurance, and Insurer Qualifications	GC.37
G7.28	Disposal of Material Outside the Work Site	GC.38
G7.29	Cooperation	GC.38
G7.30	Occupancy Prior to Acceptance	GC.38
G7.31	Acceptance of the Work	GC.39
G7.32	Property Rights in Materials	GC.39
G7.33	Rights in Land and Improvements	GC.39
G7.34	Antitrust Claims	GC.39
G7.35	Access to the Work	GC.39
G7.36	Personal Liability	GC.39
G7.37	Third Party Rights	GC.39
G7.38	Independent Contractor Status	GC.39

Section 8	Prosecution and Progress	GC.40
	G8.01 Subcontracting	GC.40
	G8.02 Assignment	GC.40
	G8.03 Notice to Proceed	GC.40
	G8.04 Beginning of Work	GC.41
	G8.05 Schedules and Progress Reports	GC.41
	G8.06 Site Meetings	GC.41
	G8.07 Time of Completion	GC.41
	G8.08 Additional Shift Work	GC.41
	G8.09 Unusual Materials in Excavations	GC.41
	G8.10 Owner's Right to Stop the Work	GC.42
	G8.11 Liquidated Damages	GC.42
	G8.12 Delays and Extensions of Time	GC.43
	G8.13 Termination of Right to Proceed	GC.44
	G8.14 Termination of Contract	GC.44
	G8.15 Existing Utilities	GC.46
	G8.16 Temporary Utilities	GC.46
	G8.17 Office of Contractor at Site	GC.46
	G8.18 Preservation of Stakes and Marks	GC.46
	G8.19 Suggestions to Contractor	GC.47
	G8.20 Use of Explosives	GC.47

Section 9	Measurement and Payment	GC.48
	G9.01 Measurement of Quantities	GC.48
	G9.02 Scope of Payment	GC.48
	G9.03 Force Account Payment	GC.48
	G9.04 Records	GC.48
	G9.05 Notice of Potential Claim	GC.49
	G9.06 Stop Notices	GC.49
	G9.07 Payment Schedules	GC.49
	G9.08 Invoice for Work Completed	GC.49
	G9.09 Retention	GC.50
	G9.10 Partial Payments	GC.50
	G9.11 Payment of Withheld Funds	GC.50
	G9.12 Final Payment and Claims	GC.50
	G9.13 Claims Procedures	GC.51

PART III SPECIAL CONDITIONS WHITE

Section 1	Special Conditions	SC.1
	S1.01 Patents, Royalties, Licensing (Additional Conditions)	SC.1
	S1.02 Representative Sewer Rehabilitation Section	SC.1
	S1.03 Variations in the Representative Sewer Rehabilitation Section	SC.2
	S1.04 Contract Duration	SC.3
	S1.05 Contract Amount	SC.3
	S1.06 Invoice Form	SC.3
	S1.07 Payment	SC.3
	S1.08 Notification	SC.4
	S1.09 Mobilization Costs and Payment	SC.4
	S1.10 Preliminary Inspection	SC.4
	S1.11 Time for Completion	SC.4

S1.12	Occupancy Prior to Acceptance	SC.4
S1.13	Liquidated Damages	SC.4
S1.14	Contract Termination	SC.5
	Standard Sewer Rehabilitation Invoice	SC.7

PART IV	TECHNICAL CONDITIONS	<u>WHITE</u>
Section 1A	Instructions	1A.1
	1. Definitions	1A.1
	2. Licensing of Bidders	1A.1
	3. Permits	1A.1
	4. Project Signs	1A.1
	5. Public Notification	1A.1
	6. Work Within Easements	1A.2
	7. Preservation of Property and Cleaning	1A.2
	8. Storage of Materials	1A.2
	9. Debris Removal From Pipeline Construction Operations	1A.3
	10. Arbitration	1A.3
	11. Inspection	1A.3
	12. Work Hours	1A.3
Section 2A	Excavation, Trenching and Backfilling	2A.1
	Part 1 General	2A.1
	1. Application Publications	2A.1
	2. Definitions	2A.1
	3. Soils Report	2A.1
	4. Trench Excavation Safety Plans	2A.2
	5. Maintaining Traffic	2A.2
	6. Archeological Discoveries	2A.3
	Part 2 Execution	2A.5
	7. Utility Crossings	2A.5
	8. Pavement Cutting	2A.5
	9. Trench Excavation	2A.5
	10. Earthwork	2A.7
	11. Structure Excavation	2A.7
	12. Backfill	2A.7
	13. Surplus Material	2A.8
	14. Dust Control	2A.8
	15. Existing Facilities	2A.9
	16. Measurement and Pavement	2A.9
Section 2B	Sanitary Sewers	2B.1
	Part 1 General	2B.1
	1. Applicable Publications	2B.1
	Part 2 Products	2B.2
	2. General	2B.2
	Part 3 Execution	2B.5

	3.	Pipe Installation	2B.5
	4.	Manholes	2B.8
	5.	Manhole Rehabilitation	2B.10
	6.	Manhole Abandonment	2B.11
	7.	Manhole Removal	2B.11
	8.	Manhole Frame Repair	2B.11
	9.	Junction Boxes	2B.12
	10.	Stubs	2B.13
	11.	Testing of Sewers	2B.14
Section 2C		Paving	2C.1
	Part 1	General	2C.1
	1.	General	2C.1
	Part 2	Products	2C.1
	2.	Aggregate Base	2C.1
	3.	Asphalt Concrete	2C.1
	4.	Concrete	2C.1
	5.	Traffic Markings	2C.1
	Part 3	Execution	2C.1
	6.	Trench Resurfacing	2C.1
	7.	Traffic Markings	2C.1
	8.	Inductive Loop Detectors	2C.1
	9.	Measurement and Payment	2C.2
Section 2D		Concrete	2D.1
	Part 1	General	2D.1
	1.	Applicable Publications	2D.1
	2.	General	2D.1
	3.	Storage	2D.1
	Part 2	Products	2D.1
	4.	Materials	2D.1
	5.	Concrete Quality	2D.2
	Part 3	Execution	2D.2
	6.	Form Work	2D.2
	7.	Reinforcement	2D.2
	8.	Installation of Anchorage Items	2D.3
	9.	Placing	2D.3
	10.	Consolidation of Concrete	2D.3
	11.	Field Quality Control Tests	2D.3
	12.	Finishes	2D.3
	13.	Curing	2D.3
Section 2E		Trenchless Replacement (Pipe Sliplining/Bursting)	2E.1
	Part 1	General	2E.1
	1.	General	2E.1
	2.	Applicable Publications	2E.1
	3.	Approvals	2E.1

Part 2	Equipment	2E.2
4.	Pipe Sliplining/Bursting Unit	2E.2
5.	Sliplining/Bursting	2E.2
6.	Pulling Unit	2E.3
Part 3	Material	2E.4
7.	Pipe and Fitting	2E.4
8.	Pipe Joint	2E.4
9.	Concrete	2E.4
10.	Manholes	2E.4
Part 4	Execution	2E.5
11.	Sewage Bypassing	2E.5
12.	Method of Sliplining/Bursting	2E.5
13.	Manhole Connections	2E.5
14.	Insertion and Pulling Pits	2E.5
15.	Pipe Insertion	2E.6
16.	Laterals	2E.6
17.	Manholes	2E.7
18.	Backfill and Compaction	2E.7
19.	Testing	2E.7
20.	Restoration	2E.8
Section 2F	Trenchless Replacement - Cured-in-Place Pipe (CIPP)	2F.1
Part 1	General	2F.1
1.	General	2F.1
2.	Applicable Publications	2F.1
3.	Approvals	2F.1
Part 2	Description	2F.2
4.	Cured-in-Place Pipe	2F.2
Part 3	Materials	2F.3
5.	Tube	2F.3
6.	Resin/Catalyst	2F.3
7.	Finished and Cured Liner Properties	2F.3
8.	Concrete	2F.4
9.	Manholes	2F.4
Part 4	Execution	2F.5
10.	Sewage Bypassing	2F.5
11.	Installation	2F.5
12.	Laterals	2F.5
13.	Manholes	2F.6
14.	Testing	2F.6
15.	Restoration	2F.7
16.	Warranty and Quality Assurance	2F.7
17.	Measurement and Payment	2F.8

PART V DRAWINGS

- A. Detail 1 – Representative Sanitary Sewer Pipe Section

	Detail 2 – Bedding and Backfill	1 / 4
B.	Detail 3 – Manhole Connections for HDPE Liner Pipe	
	Detail 4 – Lateral Reconnection for HDPE Liner Pipe	2 / 4
C.	Detail 5 – Standard Main Manhole Structure	
	Detail 6 – Rodding Inlet Structure	3 / 4
D.	Detail 7 – Cleanout with Backflow Prevention Device	
	Detail 8 – Point Repair	4 / 4

(This page left blank intentionally)

STEGE SANITARY DISTRICT
CONTRA COSTA COUNTY, CALIFORNIA

**NOTICE TO CONTRACTORS
INVITING SEALED PROPOSALS**

NOTICE IS HEREBY GIVEN that sealed proposals or bids will be received by the Stege Sanitary District (Owner) at the District's Office at 7500 Schmidt Lane, El Cerrito, California 94530 until Tuesday, **JULY 24, 2012 @ 2:00 P.M.**, at which time they will be publicly opened and read for performing work as follows:

**STEGE SANITARY DISTRICT
STANDARD SEWER REHABILITATION PROJECT
PROJECT NO. 12201 – JULY 2012**

Bids may be delivered to the District Secretary at the District Office at the above address between 9:00 A.M and 4:30 P.M., Monday through Friday or mailed to Stege Sanitary District at 7500 Schmidt Lane, El Cerrito, California 94530.

The principal items of work are:

Sewer Rehabilitation of Existing Sewers at Various Locations in the Stege Sanitary District

The basis of Award of Contract is the lowest Total Amount Bid by a responsible Contractor. No bid will be received unless it is made on the proposal form furnished by the Owner in the bid documents. The contract, if awarded, will be awarded within one-hundred twenty (120) days from the opening of the bids.

No bidder may withdraw his proposal for a period of one-hundred twenty (120) days after the date set for opening of proposals.

All bids are to be compared on the basis of the Engineer's estimate of the quantities of work to be done. The Engineer's estimate is available upon request.

Bids must be accompanied by a proposal guaranty in the amount of **twenty (20) percent** of the bid as described in the specifications. Said guaranty shall be in the form of a certified check, cashier's check, or bid bond executed on the prescribed form in the amount not less than **twenty (20) percent** of the amount bid. Said guaranty shall be forfeited to the Owner in case the bidder depositing the same does not, within ten (10) days after written notice that the contract has been awarded to the bidder, 1) enter into a contract with the District, and 2) furnish Performance Bond, Labor and Materials Bonds, Insurance Certificates, Contractor Safety Orientation and Contractor Self Certification Worksheet as described in the specifications.

Pursuant to California Code of Civil Procedures Section 995.311, the District will verify all bonds for this Project are issued and executed by a California admitted surety.

The special attention of prospective bidders is called to the "Instructions to Bidders" of the specifications for full directions as to bidding and related matters.

A pre-bid meeting will be held at 10:00 A.M on Tuesday, July 17, 2012 at the Stege Sanitary District Offices, 7500 Schmidt Lane, El Cerrito, California. Attendance at the pre-bid meeting is mandatory. Any bid submitted by a contractor who did not attend the pre-bid meeting will be deemed to be not responsive and shall be rejected.

The Owner reserves the right to reject any or all proposals or to waive any irregularities or informalities in any proposal or in the bidding.

Time of completion for this work is three hundred and sixty five (365) calendar days from the date of the start of

work designated in the "Notice to Proceed" but may be extended, by mutual agreement, between the OWNER and bidder for an additional three hundred and sixty five (365) calendar days.

The District has determined the general prevailing rate of per diem wages in the locality in which this work is to be performed for each craft or type of work needed to execute the contract to be as published by the State of California, Department of Industrial Relations, Division of Labor Statistics and Research, a copy of which is on file in the office of the District.

It shall be mandatory upon the Contractor to whom the contract is awarded and upon any subcontractor working under his supervision to pay not less than the above rates to all workmen employed by them in the execution of the contract. The successful bidder shall post a copy of such determinations at each job site.

The successful bidder intending to use a craft or classification not shown on the prevailing rate determinations may be required to pay the rate of the craft or classification most closely related to it.

The Contract Documents may be examined at the following locations:

Builders Exchange of Alameda County, San Leandro
Builders Exchange of Contra Costa County, Concord
Reed Construction Data, Norcross, GA
Sierra Contractors Exchange, Burson
Placer County Builders Exchange, Auburn
Nevada County Contractors, Grass Valley
Construction Bidboard, San Diego
Stege Sanitary District, El Cerrito

Copies of the plans and specifications, forms of proposals, bonds and contract may be obtained at the office of the Stege Sanitary District, 7500 Schmidt Lane, El Cerrito, California 94530 (510) 524-4668, upon payment of \$30.00 per set if picked up or upon payment of \$40.00 per set if mailed. All payments are non-refundable.

In accordance with the provisions of California Public Contract Code Section 3300, the Owner has determined that the Contractor shall possess a valid Engineering Class A, Pipeline Class C-34, or Sewer Contractor Class C-42 license at the time that the contract is awarded. Failure to possess the specified license(s) shall render the bid as non-responsive and shall act as a bar to award of the contract to any bidder not possessing said license(s) at the time of award.

Stege Sanitary District

Date: 6/07/2012

STEGE SANITARY DISTRICT
Contra Costa County, California

INSTRUCTION TO BIDDERS

1. Bidder's attention is directed to the conditions of the General Conditions for the requirements and conditions which must be adhered to in the preparation of the proposal form and submission of this proposal.
2. Proposals shall be submitted in a sealed envelope, addressed to STEGE SANITARY DISTRICT. Each sealed envelope containing a Bid must be plainly marked on the outside as:

**STEGE SANITARY DISTRICT
STANDARD SEWER REHABILITATION PROJECT
PROJECT NO. 12201 – JULY 2012**

and the envelope should bear the Bidder's address, and Contractor's license number on the outside. If forwarded by mail, the sealed envelope containing the Bid must be enclosed in another envelope addressed to STEGE SANITARY DISTRICT, 7500 SCHMIDT LANE, EL CERRITO, CALIFORNIA 94530.

3. Bidder's attention is directed to the requirements to complete and sign the following documents **WHICH ARE TO BE SUBMITTED WITH THE BID**:
 1. List of Subcontractors.
 2. Receipt of Addenda.
 3. Bidder's Experience Statement.
 4. Personnel Experience Statement.
 5. Contractor's License Statement.
 6. Non-Collusion Affidavit. (to be Notarized)
 7. Security for Compensation Certification.
 8. Bid Bond.
 9. Certification Concerning State Labor Standards and Prevailing Wages.
 10. Non-Discrimination Clause.
 11. Safety Program Qualification Criteria – Experience Modification Rate (EMR or Exmod).
 12. Safety Program Qualification Criteria – Recordable Incident Rate (RIR).
 13. Safety Program Qualification Criteria – Lost Time Incident Rate (LTIR).

The forms for the **Performance Bond, Labor and Material Bond** and the **Agreement** are attached herein for information and reference only and are to be filled out by the successful bidder upon instructions by the Owner. The **Contractor Safety Orientation** and **Contractor Self Certification Worksheet**, provided during the Pre-Bid meeting, are also to be completed and signed by the successful bidder upon instructions by the Owner prior to award.

4. All Bids shall be made on the required Bid forms supplied herein. All blank spaces for Bid prices must be filled in, in ink or typewritten, and the Bid forms must be fully completed and executed when submitted. Only one copy of the Bid forms is required.
5. The District (the OWNER) may waive any informalities or minor defects or reject any or all Bids. Any Bid may be withdrawn prior to the scheduled time for the opening of Bids or authorized postponement thereof. Any Bid received after the time and date specified shall not be considered. Should there be reasons why the contract cannot be awarded within the specified period; the time may be extended by mutual agreement between the OWNER and the Bidder.

6. Bidders must satisfy themselves of the accuracy of the estimated quantities in the Bid schedule by examination of the site and a review of the drawings and specifications including Addenda. After Bids have been submitted, the Bidder shall not assert that there was a misunderstanding concerning the quantities of work or of the nature of the work to be done.
7. The Contract Documents contain the conditions required for the construction of the Project. Information obtained from an officer, agent, or employee of the OWNER or any other person shall not affect the risks or obligations assumed by the Contractor or relieve the Contractor from fulfilling any of the conditions of the contract.
8. Each Bid must be accompanied by a **Proposal Guaranty** payable to the OWNER in the amount of not less than **twenty (20) percent** of the Bid. Such guaranty shall be in the form of a certified check, cashier's check, or bid bond executed on the prescribed form in the amount not less than **twenty (20) percent** of the amount bid. As soon as the Bid prices have been compared and reported to the Owner, the Owner will return the Proposal Guaranties of all except the three lowest responsive, responsible Bidders. When the Agreement is executed the Proposal Guaranties of the two remaining Bidders will be returned.
9. A **Performance Bond** and a **Labor and Material Bond** each in the amount of **one million dollars (\$1,000,000)**, with a corporate surety approved by the OWNER will be required for the faithful performance of the contract. The bond forms provided in this document must be used.
10. Attorneys-in-fact who sign Bid Bonds or Performance Bonds and Labor and Material Bonds must file with each Bond a certified and effective dated copy of their power of attorney.
11. If the surety on any bond furnished by the Bidder is declared bankrupt, or becomes insolvent, or its right to do business is terminated, the Bidder shall, within five (5) days thereafter, notify the OWNER and substitute another bond and surety, both of which must be acceptable to the OWNER.
12. The party to whom the contract is awarded will be required to execute the Agreement and provide the necessary insurance certifications within ten (10) calendar days from the date the Notice of Award is delivered to the Bidder. The Notice of Award shall be accompanied by the necessary Agreement.

The amount payable to the Owner under the proposal guaranty bond shall be forfeited to the Owner as liquidated damages in case of a failure of the Bidder to furnish, execute and deliver to the Owner the required performance bond, labor and material bond, evidence of insurance, and to enter into, execute and deliver to the Owner the Agreement on the form provided herewith within ten (10) days after being notified in writing by the Owner that the award has been made and the Agreement is ready for execution.
13. The OWNER within ten (10) days of receipt of an acceptable Performance Bond, Labor and Material Bond and Agreement signed by the party to whom the Agreement was awarded, shall sign the Agreement and return to such party an executed duplicate of the Agreement. Should the OWNER not execute the Agreement within such period, the Bidder may by Written Notice withdraw the signed Agreement. Such notice of withdrawal shall be effective upon receipt of the notice by the OWNER.
14. The OWNER may make such investigations as deemed necessary to determine the ability of the Bidder to perform the work, and the Bidder shall furnish to the OWNER all such information and data for this purpose as the OWNER may request. A Bidders prior history of unsatisfactory performance on work for the District shall constitute grounds for disqualifying a Bidder.
15. The OWNER reserves the right to reject any Bid if the evidence submitted by, or investigation of such Bidder fails to satisfy the OWNER that such Bidder is properly qualified to carry out the obligations of the Agreement and to complete the work contemplated therein.
16. In accordance with Section 4104 of the California Public Contract Code, each bidder, in its Bid, shall set forth: (1) the name and location of the place of business of each subcontractor who will perform work or labor, render services to the contractor in or about the construction of the work, or improvement, in an

amount in excess of one-half of one percent of the Contractor's total bid; and (2) the portion of the work which will be done by each such subcontractor. In accordance with Section 4107 of the California Public Contract Code, no Contractor whose bid is accepted shall without consent of the OWNER either: (1) substitute any person as a subcontractor in place of the subcontractor designated in the original bid; or (2) permit any such subcontract to be assigned or transferred, or allowed it to be performed by anyone other than the original subcontractor listed in the bid; or (3) Sublet or subcontract any portion of the work in excess of one-half of one percent of the Contractor's total bid as to which his original bid did not designate a subcontractor. Penalties for failure to comply with the foregoing sections of the California Public Contract Code are set forth in Section's 4106, 4110 and 4111 of the Public Contract Code.

17. Notice is hereby given that, pursuant to Section 1773 of the Labor Code of the State of California, the Owner has obtained from the Director of the Department of Industrial Relations the general prevailing rate of per diem wages and the general prevailing rate for holidays and overtime work for each craft, classification, or type of worker required to execute the contract. A copy of said prevailing rate of per diem wages is on file in the principal office of the OWNER, to which reference is hereby made for further particulars. Said prevailing rate of per diem wages will be made available to any interested party upon request, and a copy thereof shall be posted at each job site.
18. Bid specifications and contracts and other procedures in connection with bids or contracts shall be subject to modification to comply with revisions in federal minimum wage schedules without the necessity of republication of duplication of other formal statutory requirements.
19. In accordance with Section 1775 of the California Labor Code, the Contractor shall as a penalty to the State of political subdivision on whose behalf a contract is made or awarded, forfeit fifty dollars (\$50.00) for each calendar day or portion thereof, for each worker paid less than the stipulated prevailing rates for any public work done under the Contract by the Contractor or by any subcontractor under the Contractor.
20. In accordance with Section 1814 of the California Labor Code, the Contractor shall as a penalty to the State or political subdivision on whose behalf the Contractor is made or awarded, forfeit twenty-five (\$25.00) dollars for each worker employed in the execution of the Contract by the Contractor or by any subcontractor for each calendar day during which said worker is required or permitted to work more than eight (8) hours in any one calendar day and forty (40) hours in any one calendar week in violation of Section's 1810-1815 of the California Labor Code.
21. As required by Section 1860 of the California Labor Code and in accordance with the provisions of Section 3700 of the Labor Code, every contractor will be required to secure the payment of worker's compensation to its employee.
22. In accordance with Section 1860 of the California Labor Code, the Contractor shall furnish the Owner a notarized statement as follows: "I am aware of the provisions of Section 3700 of the Labor Code which requires every employer to be insured against liability for worker's compensation or to undertake self-insurance in accordance with the provisions of that code, and I will comply with such provisions before commencing the performance of the Work of this Contract."
23. Contractor agrees to comply with Section's 1777.5, 1777.6 and 1777.7 (as amended) of the California Labor Code relating to the employment of apprentices. The responsibility for compliance with these provisions is fixed with the prime contractor for all apprentice-able occupations. Under these sections of the law, contractors and sub-contractors must employ apprentices in apprentice-able occupations, where journeymen in the craft are employed on the public work, in a ration of not less than one hour of apprentice work for every five hours of labor performed by a journeyman (unless an exemption is granted in accordance with Section 1777.5) and contractors and subcontractors shall not discriminate among otherwise qualified employees as indentured apprentices on any public work solely on the ground of race, religious creed, color, national origin, ancestry, sex, or age, except as provided in Section 3077 of the Labor Code. Only apprentices, as defined in Section 3077, who are in training under apprenticeship standards and who have signed written apprentice agreements will be employed on public works in apprentice-able occupations.

24. Attention is specifically directed to all provisions of the Labor Code of the State of California and the federal Davis-Beacon Act with regard to workmen and wages. Wages shall not be less than the prevailing wage rates determined for the County of Contra Costa at the time of the bid, pursuant to said provisions and as listed in the "Wage Scales." Contractors must comply with provision of the Work Hours and Safety Standards Act (40 U.S.C. 327 ET SEQ.) and the regulations issued there-under.

As required by Section 1773.8 of the California Labor Code, the Contractor shall pay travel and subsistence payments to each worker needed to execute the work, as such travel and subsistence payments are defined in the applicable collective bargaining agreements filed in accordance with Section 1773.8.

To establish such travel and subsistence payments, the representative of any craft, classification, or type of workman needed to execute the contracts shall file with the Department of Industrial Relations fully executed copies of collective bargaining agreements for the particular craft, classification or type or work involved. Such agreements shall be filed with ten (10) days after their execution and thereafter shall establish such travel and subsistence payments whenever filed thirty (30) days prior to the call for bids.

25. The Bidders' attention is directed to Part III of the Specifications, "Special Conditions," associated with this project. The bidders shall review and understand these special requirements of the project as described under this section.

26. In accordance with Sections 20162, 20783 and 20803 of the California Public Contract Code, the following safety qualification guidelines shall be used to determine the responsible BIDDER. For a BIDDER to be considered responsible with regards to their safety record and for the BIDDER's bid to be considered, both the BIDDER and their first tier subcontractors listed on the bidders list of subcontractors shall each meet at least two of the three minimum safety standards as specified in paragraphs 26.1 through 26.3 hereinafter. BIDDER shall submit the appropriate proposal forms on pages BP.23 through BP.25 as part of the bid to demonstrate the BIDDER's and their first tier subcontractor's safety qualifications. If either BIDDER or first tier subcontractor cannot satisfy two of the three minimum safety standards, BIDDER's will be allowed the option of meeting only one of the minimum safety standards, but in doing so, the BIDDER will be required to provide the services of a third-party safety consultant specializing in the type of work to be performed that is acceptable to the Agency.

The third party safety consultant will be used in the capacity of reviewing the Contractor's Site Safety and Project Safety Plans, providing periodic monitoring of site safety at a frequency to be determined by the Agency, reviewing special safety hazards not addressed in the Contractor's safety plans and reviewing and evaluating the safety incidents that occur during the project.

26.1 Experience Modification Rate (EMR or Exmod): Experience modification rates are calculated by the insurance industry as a way to determine equitable workers' compensation insurance premiums. It is calculated as a three-year moving average. Due to the particular safety hazards inherited in working in a wastewater collection, handling, treatment and/or disposal environment, the OWNER has deemed it necessary that a BIDDER shall have a current three-year average EMR of **1.0** or lower to be considered a responsible bidder.

26.2 Recordable Incident Rate (RIR): The RIR is a measure of the frequency of injuries and is a measure of all occupational injuries and illnesses that occur within an organization. It is calculated from the OSHA Log 300 form. Due to the particular safety hazards inherited in working in a wastewater collection, handling, treatment and/or disposal environment, the OWNER has deemed it necessary that a BIDDER shall have a current three-year average RIR of **7.0** or lower to be considered a responsible bidder.

26.3 Lost Time Incident Rate (LTIR): The LTIR is an indicator of the severity of a company's occupational injuries. The LTIR deals only with incidents that result in lost work time. Like the RIR, the information needed to calculate the LTIR is derived OSHA Log 300 form. Due to the particular safety hazards inherited in working in a wastewater collection, handling, treatment and/or disposal environment, the OWNER has deemed it necessary that a BIDDER shall have a current three-year average RIR of **3.5** or lower to be considered a responsible bidder.

The **Contractor Safety Orientation** and **Contractor Self Certification Worksheet**, provided during the Pre-Bid meeting, are also to be completed and signed by the successful bidder upon instructions by the Owner prior to award.

27. Instructions to Bidders are hereby made a part of the contract documents.

(This page left blank intentionally)

BID PROPOSAL

STEGE SANITARY DISTRICT
PROJECT NO. 12201
JULY 2012

(This page left blank intentionally)

PROPOSAL FORM

**STEGE SANITARY DISTRICT
CONTRA COSTA COUNTY, CALIFORNIA**

**STANDARD SEWER REHABILITATION PROJECT
PROJECT NO. 12201 – JULY 2012**

To the Honorable Board of Directors
Stege Sanitary District
7500 Schmidt Lane
El Cerrito, California 94530-0530

Attention: Mr. Rex Delizo, District Manager

Gentlemen:

Pursuant to the contract plans and specifications, the undersigned, as bidder declares that he has carefully examined the location of the proposed work as evidenced by the attached executed statement of inspection of sites, and the specifications pertaining thereto, and he proposes and agrees if this proposal is accepted that he will contract with the Stege Sanitary District to provide all the labor, materials, necessary machinery tools, apparatus, and other means of construction and do all the work specified in the contract in the manner and time herein set forth required for the completion construction of:

**STEGE SANITARY DISTRICT
STANDARD SEWER REHABILITATION PROJECT
PROJECT NO. 12201 – JULY 2012**

Construction shall be in strict conformity with the plans and specifications dated, **JULY 2012** prepared by the Stege Sanitary District and on file at the District offices at 7500 Schmidt Lane, El Cerrito, CA. Said plans and specifications are hereby made a part hereof.

The bidder has attended the pre-bid meeting held on **Tuesday, JULY 17, 2010**, at the Stege Sanitary District Offices, 7500 Schmidt Lane, El Cerrito, CA. Attendance at the pre-bid meeting is a requirement for submitting a bid for the work.

The bidder proposes to contract with the Stege Sanitary District to perform all of the above work, including subsidiary obligations as defined in said specifications, for the following price, to wit:

(This page left blank intentionally)

**BID SCHEDULE
STANDARD SEWER REHABILITATION PROJECT
PROJECT NO. 12201**

A. BID SCHEDULE

ITEM	QTY	UNIT	DESCRIPTION	UNIT PRICE	TOTAL AMOUNT
1.	--	LS	MOBILIZATION, EXCAVATION, BEDDING, BACKFILL, COMPACTION AND SURFACE RESTORATION (INCLUDING LABOR, EQUIPMENT, SHEETING AND SHORING AND ALL DISPOSAL), COMPLETE IN PLACE, FOR THE LUMP SUM OF		\$ _____
2.	200	LF	PIPE BURST EXISTING 6"Ø PIPE WITH 6"Ø HDPE SDR17 GRAY LINER PIPE EASEMENT SECTION, COMPLETE IN PLACE, PER LINEAR FOOT AT	\$ _____	\$ _____
3.	2000	LF	PIPE BURST EXISTING 6"Ø PIPE WITH 8"Ø HDPE SDR17 GRAY LINER PIPE EASEMENT SECTION, COMPLETE IN PLACE, PER LINEAR FOOT AT	\$ _____	\$ _____
4.	200	LF	PIPE BURST EXISTING 8"Ø PIPE WITH 8"Ø HDPE SDR17 GRAY LINER PIPE EASEMENT SECTION, COMPLETE IN PLACE, PER LINEAR FOOT AT	\$ _____	\$ _____
5.	200	LF	PIPE BURST EXISTING 10"Ø PIPE WITH 10"Ø HDPE SDR17 GRAY LINER PIPE EASEMENT SECTION, COMPLETE IN PLACE, PER LINEAR FOOT AT	\$ _____	\$ _____
6.	200	LF	PIPE BURST EXISTING 12"Ø PIPE WITH 12"Ø HDPE SDR17 GRAY LINER PIPE EASEMENT SECTION, COMPLETE IN PLACE, PER LINEAR FOOT AT	\$ _____	\$ _____
7.	200	LF	PIPE BURST EXISTING 6"Ø PIPE WITH 6"Ø HDPE SDR17 GRAY LINER PIPE RIGHT-OF-WAY SECTION, COMPLETE IN PLACE, PER LINEAR FOOT AT	\$ _____	\$ _____
8.	2000	LF	PIPE BURST EXISTING 6"Ø PIPE WITH 8"Ø HDPE SDR17 GRAY LINER PIPE RIGHT-OF-WAY SECTION, COMPLETE IN PLACE, PER LINEAR FOOT AT	\$ _____	\$ _____

9.	200	LF	PIPE BURST EXISTING 8"Ø PIPE WITH 8"Ø HDPE SDR17 GRAY LINER PIPE RIGHT-OF-WAY SECTION, COMPLETE IN PLACE, PER LINEAR FOOT AT	\$ _____	\$ _____
10.	200	LF	PIPE BURST EXISTING 10"Ø PIPE WITH 10"Ø HDPE SDR17 GRAY LINER PIPE RIGHT-OF-WAY SECTION, COMPLETE IN PLACE, PER LINEAR FOOT AT	\$ _____	\$ _____
11.	200	LF	PIPE BURST EXISTING 12"Ø PIPE WITH 12"Ø HDPE SDR17 GRAY LINER PIPE RIGHT-OF-WAY SECTION, COMPLETE IN PLACE, PER LINEAR FOOT AT	\$ _____	\$ _____
12.	200	LF	CURED-IN-PLACE-PIPE (CIPP) LINE EXISTING 6"Ø PIPE EASEMENT OR RIGHT-OF-WAY SECTION, COMPLETE IN PLACE, PER LINEAR FOOT AT	\$ _____	\$ _____
13.	200	LF	CURED-IN-PLACE-PIPE (CIPP) LINE EXISTING 8"Ø PIPE EASEMENT OR RIGHT-OF-WAY SECTION, COMPLETE IN PLACE, PER LINEAR FOOT AT	\$ _____	\$ _____
14.	200	LF	CURED-IN-PLACE-PIPE (CIPP) LINE EXISTING 10"Ø PIPE EASEMENT OR RIGHT-OF-WAY SECTION, COMPLETE IN PLACE, PER LINEAR FOOT AT	\$ _____	\$ _____
15.	200	LF	CURED-IN-PLACE-PIPE (CIPP) LINE EXISTING 12"Ø PIPE EASEMENT OR RIGHT-OF-WAY SECTION, COMPLETE IN PLACE, PER LINEAR FOOT AT	\$ _____	\$ _____
16.	20	EA	RECONNECT AND SEAL PIPE CONNECTIONS TO EXISTING MANHOLE STRUCTURE EASEMENT OR RIGHT-OF-WAY SECTION, COMPLETE IN PLACE, EACH AT	\$ _____	\$ _____
17.	20	EA	REINFORCED CONCRETE MANHOLE STRUCTURE EASEMENT SECTION, COMPLETE IN PLACE, EACH	\$ _____	\$ _____
18.	20	EA	REINFORCED CONCRETE MANHOLE STRUCTURE RIGHT-OF-WAY SECTION, COMPLETE IN PLACE, EACH	\$ _____	\$ _____

19.	20	EA	REINFORCED CONCRETE MANHOLE FRAME & COVER REPAIR IN PAVED CONCRETE AREAS, COMPLETE IN PLACE, INCL. MOBILIZATION, EACH	\$ _____	\$ _____
20.	10	EA	POLYETHYLENE MANHOLE STRUCTURE, COMPLETE IN PLACE EASEMENT SECTION, EACH AT	\$ _____	\$ _____
21.	10	EA	MANHOLE STRUCTURE REHABILITATION, COMPLETE IN PLACE RIGHT-OF-WAY SECTION, EACH AT	\$ _____	\$ _____
22.	5	EA	LOCATE AND REPLACE RODDING INLET STRUCTURE, COMPLETE IN PLACE EASEMENT SECTION, EACH	\$ _____	\$ _____
23.	5	EA	LOCATE AND REPLACE RODDING INLET STRUCTURE, COMPLETE IN PLACE RIGHT- OF-WAY SECTION, EACH	\$ _____	\$ _____
24.	5	EA	LOCATE AND ABANDON MANHOLE STRUCTURE, COMPLETE IN PLACE EASEMENT SECTION, EACH	\$ _____	\$ _____
25.	5	EA	LOCATE AND ABANDON MANHOLE STRUCTURE, COMPLETE IN PLACE RIGHT- OF-WAY SECTION, EACH	\$ _____	\$ _____
26.	40	EA	LOCATE AND RECONNECT SEWER LATERALS TO HDPE PIPE EASEMENT SECTION, COMPLETE IN PLACE, EACH AT	\$ _____	\$ _____
27.	40	EA	LOCATE AND RECONNECT SEWER LATERALS TO HDPE PIPE RIGHT-OF-WAY SECTION, COMPLETE IN PLACE, EACH AT	\$ _____	\$ _____
28.	4	EA	LOCATE AND RECONNECT SEWER LATERALS TO CIPP PIPE EASEMENT OR RIGHT-OF-WAY SECTION, COMPLETE IN PLACE, EACH AT	\$ _____	\$ _____
29.	4	EA	PIPE BURST UP TO 60LF OF EXISTING 4"Ø SEWER LATERAL PIPE WITH 4"Ø HDPE SDR17 LINER PIPE EASEMENT SECTION, COMPLETE IN PLACE, EACH AT	\$ _____	\$ _____
30.	4	EA	PIPE BURST UP TO 60LF OF EXISTING 4"Ø SEWER LATERAL PIPE WITH 4"Ø HDPE SDR17 LINER PIPE RIGHT-OF-WAY SECTION, COMPLETE IN PLACE, EACH AT	\$ _____	\$ _____

31.	4	EA	INSTALL CLEANOUT WITH BACKFLOW PREVENTION DEVICE (BPD) EASEMENT SECTION, COMPLETE IN PLACE, EACH AT	\$ _____	\$ _____
32.	4	EA	POINT REPAIR (IN CONJUNCTION WITH PIPE REPLACEMENT) RIGHT-OF-WAY OR EASEMENT SECTION, COMPLETE IN PLACE, EACH AT	\$ _____	\$ _____
33.	10	EA	POINT REPAIR (INDEPENDENT OF PIPE REPLACEMENT) RIGHT-OF-WAY OR EASEMENT SECTION, COMPLETE IN PLACE, INCL. MOBILIZATION, EACH AT	\$ _____	\$ _____
34.	100	CY	AC PAVING, COMPLETE IN PLACE, PER CUBIC YARD AT	\$ _____	\$ _____
35.	400	CY	CLASS 2 AGGREGATE BASE, COMPLETE IN PLACE, PER CUBIC YARD AT	\$ _____	\$ _____
36.	100	CY	SIDEWALK CONCRETE PAVING, COMPLETE IN PLACE, PER CUBIC YARD AT	\$ _____	\$ _____
37.	20	CY	CONCRETE ENCASE PIPE, COMPLETE IN PLACE, PER CUBIC YARD AT	\$ _____	\$ _____
38.	--	LS	PERMIT FEES (Actual fees to be reimbursed by OWNER)		\$ <u> N/A </u>

TOTAL AMOUNT BID:

	\$ _____
(FIGURE IN WORDS)	(IN FIGURES)

BASIS OF AWARD: The basis of Award of Contract is the lowest Total Base Bid by a responsible Contractor. The Owner reserves the right to reject any and all proposals and to waive any informality in any proposal or bid. A Contractor's prior history of unsatisfactory performance on work for the OWNER constitutes grounds for disqualifying the Contractor's bid for the work.

The undersigned understands the estimate of construction items hereinbefore set forth is approximate only, being given as a basis for the comparison of bids and the Stege Sanitary District does not expressly or by implication agree that the actual amount of work will correspond therewith, but reserves the right to increase or decrease the extent of any item of the work or to omit items of the work as may be deemed necessary or expedient by the Engineer or required by funding limitations.

The undersigned understands all bids will be compared on the basis of the Engineer's Estimate of the items of the work to be done. The undersigned has checked carefully all of the above figures and understands that the Stege Sanitary District shall not be responsible for any errors or omissions on the part of the undersigned in making up this bid.

In accordance with Section 4552 of the California Public Contract Code, the bidder agrees that if the bid is accepted, it will assign to the Owner all rights, title and interest in and to all causes of action it may have under Section 4 of the Clayton Act (15 U.S.C. Section 15) or under the Cartwright Act (Chapter 2 (commencing Section 16700) of Part 2 of Division 7 of the California Business and Professions Code), arising from purchase of goods, materials, or services by the bidder for sale to the Owner pursuant to the bid. Such assignment shall be made and become effective at the time the Owner tenders final payment to the bidder.

The undersigned understands that the Stege Sanitary District reserves the right to reject any or all bids and to waive any information or irregularities in bids received and may at its option make the award that in the judgment of the Owner is in the best interest of the Owner.

It is agreed that this bid may not be withdrawn for a period of one-hundred twenty (120) days from the opening thereof. The terms and conditions of the final contract when executed shall control and supersede anything herein to the contrary or inconsistent with such contract.

Attached is the proposal guaranty bond form bound herewith, duly executed in the amount of **twenty (20) percent** of the bid as described in the specifications; or alternately there is attached a certified or cashier's check payable to the Owner in the amount not less than **twenty (20) percent** of the amount bid. If we choose to attach a proposal bond, we understand and agree that the Owner may reject our proposal if the surety does not meet the requirements of Section G2.09, or if Owner has cause to believe the surety is likely to be incapable of fulfilling its obligations under the bond.

As part of this proposal the undersigned has filled out, executed and notarized where indicated the forms included herein and listed as follows:

1. List of Subcontractors
2. Receipt of Addenda.
3. Bidder's Experience Statement.
4. Personnel Experience Statement.
5. Contractor's License Statement.
6. Non-Collusion Affidavit (To be notarized)
7. Security for Compensation Certification.
8. Bid Bond.
9. Certification Concerning State Labor Standards and Prevailing Wages.
10. Non-Discrimination Clause.
11. Safety Program Qualification Criteria – Experience Modification Rate (EMR or Exmod).
12. Safety Program Qualification Criteria – Recordable Incident Rate (RIR).
13. Safety Program Qualification Criteria – Lost Time Incident Rate (LTIR).

Name under which business is conducted _____

Business Address: _____ ZIP: _____

Telephone No.: _____ Fax: _____

Contractor's License No.: _____ Exp. Date: _____

NOTE: If bidder, or other interested person is a corporation, the legal name of the corporation shall be set forth together with the names of the president, secretary, treasurer, and manager thereof; also, signature of the officer or officers authorized to sign contracts on behalf of the corporation.

If the bidder is a co-partnership, state true name of firm; also, names of all individual co-partners composing the firm and the signature of the partner or partners authorized to sign contracts in behalf of the co-partnership.

If the bidder is an individual, state first and last name in full, together with signature.

IF SOLE OWNER, sign here:

I sign as sole owner of the business named above.

_____ Date: _____

IF PARTNERSHIP, sign here:

The undersigned certify that they sign the contract proposal with full and proper authorization so to do.
(One or more partners sign)

_____ Date: _____

_____ Date: _____

IF CORPORATION, execute here:

The undersigned certify that they sign this contract proposal with full and proper authorization so to do:

Corporate Name: _____

By: _____ Title: _____

By: _____ Title: _____

Incorporated under the laws of the State of _____

LIST OF SUBCONTRACTORS

In compliance with the provisions of Sections 4100-4107 of the Public Contract Code of the State of California and any amendments thereof, the name and location of the mill, shop or office of each Subcontractor who will perform work or labor or render services to the Contractor in or about the construction of the work or improvement to be performed under these specifications and which work will be in excess of 1/2 of 1 percent of the total proposal and the portion of the work which will be done by each Subcontractor are set forth below.

NAME AND PLACE OF BUSINESS OF SUBCONTRACTOR	PORTION OF WORK TO BE DONE (%)
1. _____	_____
2. _____	_____
3. _____	_____
4. _____	_____
5. _____	_____

Signature of Bidder

Company Name

Date

CONTRACTOR'S LICENSE STATEMENT

Contractor: _____

Address: _____

Telephone No. (_____) _____

License No.: _____

Classification: _____

License Expiration Date: _____

"I declare under the penalty of perjury under the laws of the State of California that the foregoing is true and correct."

Executed this _____ day of _____, 20____, at _____, California.

Signature of Contractor

NON-COLLUSION AFFIDAVIT

NON-COLLUSION AFFIDAVIT
TO BE EXECUTED BY BIDDER AND SUBMITTED WITH BID

State of California

County of _____

_____ ; being first duly sworn, deposes and says that he or she is

_____ of _____

the party making the foregoing bid, that the bid is not made in the interest of, or on behalf of, any undisclosed person, partnership, company, association, organization, or corporation; that the bid is genuine and not collusive or sham; that the bidder has not directly or indirectly induced or solicited any other bidder to put in a false or sham bid, and has not directly or indirectly colluded, conspired, connived, or agreed with any bidder or anyone else to put in a sham bid, or that anyone shall refrain from bidding; that the bidder has not in any manner, directly or indirectly, sought by agreement, communication, or conference with anyone to fix the bid price of the bidder or any other bidder, or to fix any overhead, profit, or cost element of the bid price, or of that of any other bidder, or to secure any advantage against the public body awarding the contract of anyone interested in the proposed contract; that all statements contained in the bid are true; and, further, that the bidder has not, directly or indirectly, submitted his or her bid price or any breakdown thereof, or the contents thereof, or divulged information or data relative thereto, or paid, and will not pay, any fee to any corporation, partnership, company association, organization, bid depository, or to any member or agent thereof to effectuate a collusive or sham bid.

By _____

personally known to me OR proved to me on the basis of satisfactory evidence to be the person(s) whose name(s) is/are subscribed to the within instrument and acknowledged to me that he/she/they executed the same in his/her/their authorized capacity(ies), and that by his/her/their signatures(s) on the instrument the person(s), or entity upon behalf of which the person(s) acted, executed the instrument.

Subscribed and sworn to before me on _____

(Notary Public)

SECURITY FOR COMPENSATION CERTIFICATE

TO: _____

I am aware of the provisions of Section 3700 of the Labor Code of the State of California which require every employer to be insured against liability for workman's compensation or to undertake self insurance in accordance with the provisions of that Code, and I will comply with such provisions before commencing the performance of the work of this Contract.

(Signature of Bidder)

Business Address

Place of Residence

The successful bidder prior to the award of contract must execute this certificate. The bidder shall execute the certificate on this page at the time of submitting his bid proposal.

(This page left blank intentionally)

BID BOND
(20% of Bid Price)

KNOW ALL MEN BY THESE PRESENTS:

THAT _____, hereinafter called the Principal, and _____, hereinafter called the Surety, are jointly and severally held and firmly bound unto Stege Sanitary District, hereinafter call the Obligee, each in the penal sum of **twenty (20) percent** of the total amount of the bid proposal of the Principal for the work, this sum not to exceed _____dollars of lawful money of the United States for the payment whereof unto the Obligee the Principal and Surety jointly and severally bind themselves forever by these presents.

WHEREAS the Principal is herewith submitting its offer for the fulfillment of the Stege Sanitary District contract for STANDARD SEWER REHABILITATION PROJECT NO. 12201 – JULY 2012 as provided for in the Contract Documents.

NOW THEREFORE, the condition of the obligation is such that if the Principal is awarded the contract, and if the Principal within the time specified in the proposal for such contract enters into, executes and delivers to the Obligee an agreement in the form provided herein complete with evidences of insurance, then this obligation shall be void; otherwise, the Principal and Surety will pay unto the Obligee the difference in money between the total amount of the proposal of the principal and the amount for which the Obligee legally contracts with another party to fulfill the contract if the latter amount be in excess of the former, but in no event shall the Surety's liability exceed the penal sum hereof.

AND IT IS HEREBY DECLARED AND AGREED that the Surety shall be liable under this obligation as Principal and that nothing of any kind or nature whatsoever that will not discharge the Principal shall operate as a discharge or a release of liability of the Surety.

IT IS HEREBY FURTHER DECLARED AND AGREED that this obligation shall be binding upon and inure to the benefit of the Principal, the Surety and the Obligee and their respective heirs, executors, administrators, successors and assigns.

SIGNED AND SEALED THIS _____ day of _____, 20__.

(This page left blank intentionally)

**CONTRACTOR'S/SUBCONTRACTOR'S CERTIFICATION
CONCERNING STATE LABOR STANDARDS AND PREVAILING WAGES**

All contractors and subcontractors shall give the following certifications to the grantee and forward this certification to the grantee within ten (10) days after the execution of any contract or subcontract.

- A. "I am aware of the provisions of Section 1720 et seq. of the California Labor Code which requires that the State prevailing wage rate shall be paid to employees where this rate exceeds the federal wage rate."

- B. "I am aware of the provisions of Section 3700 of the Labor Code which require every employer to be insured against liability for workers' compensation or to undertake self-insurance in accordance with the provisions of that Code, and I will comply with such provisions before commencing the performance of the work of this contract."

- C. "Contractor stipulates and agrees to conform with all provisions of Labor Code, Sections 1810 through 1815, eight (8) hours labor shall constitute a legal day's work, and no worker shall be required or permitted to work more than eight (8) hours in any one (1) calendar day and forty (40) hours in any one (1) calendar week, except as provided for under Section 1815. Nothing in this provision shall be construed to relate to wage determination or in any way affect contractual provisions related to compensation.

Notwithstanding the Labor Code provision set forth above, pursuant to Labor Code, Section 1815, work performed by employees of Contractor in excess of eight (8) hours per day and forty (40) hours during any one (1) week shall be permitted provided that compensation shall be made for all hours worked in excess of eight (8) hours per day at not less than one and one-half (1-1/2) times the basic rate of pay.

(Contractor/Subcontractor)

By: _____
(Signature)

(Typed Name and Title)

NON-DISCRIMINATION CLAUSE

During the performance of this contract, the contractor agrees as follows:

(1) The contractor will not discriminate against any employee or applicant for employment because of race, color, religion, sex, or national origin. The contractor will take affirmative action to ensure that applicants are employed, and that employees are treated during employment, without regard to their race, color, religion, sex, or national origin. Such action shall include, but not be limited to the following: Employment, upgrading, demotion, or transfer, recruitment or recruitment advertising; layoff or termination; rates of pay or other forms of compensation; and selection for training, including apprenticeship. The contractor agrees to post in conspicuous places, available to employees and applicants for employment, notices to be provided by the contracting officer setting forth the provisions of this nondiscrimination clause.

(2) The contractor will, in all solicitations or advertisements for employees placed by or on behalf of the contractor, state that all qualified applicants will receive consideration for employment without regard to race, color, religion, sex, or national origin.

(3) The contractor will send to each labor union or representative of workers with which he has a collective bargaining agreement or other contract or understanding, a notice to be provided by the agency contracting officer, advising the labor union or workers' representative of the contractor's commitments under section 202 of Executive Order 11246 of September 24, 1965, and shall post copies of the notice in conspicuous places available to employees and applicants for employment.

(4) The contractor will comply with all provisions of Executive Order 11246 of September 24, 1965, and of the rules, regulations, and relevant orders of the Secretary of Labor.

(5) The contractor will furnish all information and reports required by Executive Order 11246 of September 24, 1965, and by the rules, regulations, and orders of the Secretary of Labor, or pursuant thereto, and will permit access to his books, records, and accounts by the contracting agency and the Secretary of Labor for purposes of investigation to ascertain compliance with such rules, regulations, and orders.

(6) In the event of the contractor's non-compliance with the nondiscrimination clauses of this contract or with any of such rules, regulations, or orders, this contract may be canceled, terminated or suspended in whole or in part and the contractor may be declared ineligible for further Government contracts in accordance with procedures authorized in Executive Order 11246 of September 24, 1965, and such other sanctions may be imposed and remedies invoked as provided in Executive Order 11246 of September 24, 1965, or by rule, regulation, or order of the Secretary of Labor, or as otherwise provided by law.

(7) The contractor will include the provisions of paragraphs (1) through (7) in every subcontract or purchase order unless exempted by rules, regulations, or orders of the Secretary of Labor issued pursuant to section 204 of Executive Order 11246 of September 24, 1965, so that such provisions will be binding upon each subcontractor or vendor. The contractor will take such action with respect to any subcontract or purchase order as may be directed by the Secretary of Labor as a means of enforcing such provisions including sanctions for noncompliance: Provided, however, that in the event the contractor becomes involved in, or is threatened with, litigation with a subcontractor or vendor as a result of such direction, the contractor may request the United States to enter into such litigation to protect the interests of the United States.

(b) Federally assisted construction contracts. (1) Except as otherwise provided, each administering agency shall require the inclusion of the following language as a condition of any grant, contract, loan, insurance, or guarantee involving federally assisted construction which is not exempt from the requirements of the equal opportunity clause: The applicant hereby agrees that it will incorporate or cause to be incorporated into any contract for construction work, or modification thereof, as defined in the regulations of the Secretary of Labor at 41 CFR Chapter 60, which is paid for in whole or in part with funds obtained from the Federal Government or borrowed on the credit of the Federal Government pursuant to a grant, contract, loan insurance, or guarantee, or undertaken pursuant to any Federal program involving such grant, contract, loan, insurance, or guarantee, the following equal opportunity clause:

During the performance of this contract, the contractor agrees as follows:

1. The contractor will not discriminate against any employee or applicant for employment because of race, color, religion, sex, or national origin. The contractor will take affirmative action to ensure that applicants are employed, and that employees are treated during employment without regard to their race, color, religion, sex, or national origin. such action shall include, but not be limited to the following: Employment, upgrading, demotion, or transfer; recruitment or recruitment advertising; layoff or termination; rates of pay or other forms of compensation; and selection for training, including apprenticeship. The contractor agrees to post in conspicuous places, available to employees and applicants for employment, notices to be provided setting forth the provisions of this nondiscrimination clause.

2. The contractor will, in all solicitations or advertisements for employees placed by or on behalf of the contractor, state that all qualified applicants will receive considerations for employment without regard to race, color, religion, sex, or national origin.

3. The contractor will send to each labor union or representative of workers with which he has a collective bargaining agreement or other contract or understanding, a notice to be provided advising the said labor union or workers' representatives of the contractor's commitments under this section, and shall post copies of the notice in conspicuous places available to employees and applicants for employment.

4. The contractor will comply with all provisions of Executive Order 11246 of September 24, 1965, and of the rules, regulations, and relevant orders of the Secretary of Labor.

5. The contractor will furnish all information and reports required by Executive Order 11246 of September 24, 1965, and by rules, regulations, and orders of the Secretary of Labor, or pursuant thereto, and will permit access to his books, records, and accounts by the administering agency and the Secretary of Labor for purposes of investigation to ascertain compliance with such rules, regulations, and orders.

6. In the event of the contractor's noncompliance with the nondiscrimination clauses of this contract or with any of the said rules, regulations, or orders, this contract may be canceled, terminated, or suspended in whole or in part and the contractor may be declared ineligible for further Government contracts or federally assisted construction contracts in accordance with procedures authorized in Executive Order 11246 of September 24, 1965, and such other sanctions may be imposed and remedies invoked as provided in Executive Order 11246 of September 24, 1965, or by rule, regulation, or order of the Secretary of Labor, or as otherwise provided by law.

7. The contractor will include the portion of the sentence immediately preceding paragraph (1) and the provisions of paragraphs (1) through (7) in every subcontract or purchase order unless exempted by rules, regulations, or orders of the Secretary of Labor issued pursuant to section 204 of Executive Order 11246 of September 24, 1965, so that such provisions will be binding upon each subcontractor or vendor. The contractor will take such action with respect to any subcontract or purchase order as the administering agency may direct as a means of enforcing such provisions, including sanctions for noncompliance: Provided, however, That in the event a contractor becomes involved in, or is threatened with, litigation with a subcontractor or vendor as a result of such direction by the administering agency the contractor may request the United States to enter into such litigation to protect the interests of the United States.

The applicant further agrees that it will be bound by the above equal opportunity clause with respect to its own employment practices when it participates in federally assisted construction work: Provided, that if the applicant so participating is a State or local government, the above equal opportunity clause is not applicable to any agency, instrumentality or subdivision of such government which does not participate in work on or under the contract.

The applicant agrees that it will assist and cooperate actively with the administering agency and the Secretary of Labor in obtaining the compliance of contractors and subcontractors with the equal opportunity clause and the rules, regulations, and relevant orders of the Secretary of Labor, that it will furnish the administering agency and the Secretary of Labor such information as they may require for the supervision of such compliance, and that it will otherwise assist the administering agency in the discharge of the agency's primary responsibility for securing compliance.

The applicant further agrees that it will refrain from entering into any contract or contract modification subject to Executive Order 11246 of September 24, 1965, with a contractor debarred from, or who has not demonstrated eligibility for, Government contracts and federally assisted construction contracts pursuant to the Executive order and will carry out such sanctions and penalties for violation of the equal opportunity clause as may be imposed upon contractors and subcontractors by the administering agency or the Secretary of Labor pursuant to Part II, Subpart D of the Executive order. In addition, the applicant agrees that if it fails or refuses to comply with these undertakings, the administering agency may take any or all of the following actions: Cancel, terminate, or suspend in whole or in

part this grant (contract, loan, insurance, guarantee); refrain from extending any further assistance to the applicant under the program with respect to which the failure or refund occurred until satisfactory assurance of future compliance has been received from such applicant; and refer the case to the Department of Justice for appropriate legal proceedings.

(c) Subcontracts. Each nonexempt prime contractor or subcontractor shall include the equal opportunity clause in each of its nonexempt subcontracts.

(d) Incorporation by reference. The equal opportunity clause may be incorporated by reference in all Government contracts and subcontracts, including Government bills of lading, transportation requests, contracts for deposit of Government funds, and contracts for issuing and paying U.S. savings bonds and notes, and such other contracts and subcontracts as the Deputy Assistant Secretary may designate.

(e) Incorporation by operation of the order. By operation of the order, the equal opportunity clause shall be considered to be a part of every contract and subcontract required by the order and the regulations in this part to include such a clause whether or not it is physically incorporated in such contracts and whether or not the contract between the agency and the contractor is written.

(f) Adaptation of language. Such necessary changes in language may be made in the equal opportunity clause as shall be appropriate to identify properly the parties and their undertakings. [43 FR 49240, Oct. 20, 1978, as amended at 62 FR 66971, Dec. 22, 1997]

1. During the performance of this contract, contractor and its subcontractors shall not unlawfully discriminate against any employee or applicant for employment because of sex, race, religion, color, national origin, ancestry, physical disability (including HIV and AIDS), mental disability, medical condition (cancer), marital status, age (over 40) or denial of family care leave. Contractors and subcontractors shall insure that the evaluation and treatment of their employees and applicants for employment are free of such discrimination and harassment. Contractors and subcontractors shall comply with the provisions of the Fair Employment and Housing Act (Government Code Section 12900 (a-f) et seq.) and the applicable regulations promulgated there under (California Administrative Code, Title 2, Section 7285.0 et seq.). The applicable regulations of the Fair Employment and Housing Commission implementing Government Code, Section 12900 (a-f), set forth in Chapter 5 of Division 4 of Title 2 or the California Administrative Code are incorporated into this contract by reference and made a part hereof as if set forth in full. Contractor and its subcontractor shall give written notice of their obligations under this clause to labor organizations with which they have a collective bargaining or other agreement.

2. The contractor shall include the nondiscrimination and compliance provisions of this clause in all subcontracts to perform work under the contract.

THE UNDERSIGNED CERTIFIES THAT THE CONTRACTOR WILL COMPLY WITH THE ABOVE REQUIREMENTS.

CONTRACTOR OR
SUBCONTRACTOR NAME: _____

CERTIFIED BY:

NAME: _____ TITLE: _____

SIGNATURE: _____ DATE: _____

**SAFETY PROGRAM QUALIFICATION CRITERIA
Experience Modification Rate (EMR or Exmod)**

The following information will be used to determine if you meet the minimum safety requirements for this project. To qualify, you must not have a three-year average Workers' Compensation Experience Modification Rate greater than 1.0. This form shall be submitted by the primary contractor and first tier subcontractors.

Enter your Experience Modification Rate for the last three complete years (available from your insurance carrier).	
20_____	EMR = _____
20_____	EMR = _____
20_____	EMR = _____
Three Year Average EMR = _____	

Company Name _____

Contact Name _____ Telephone _____

To verify the above information, we will contact your workers' compensation insurance carrier. Please authorize your carrier to release this information. Failure to do so will result in automatic disqualification.

Workers' Compensation Insurance Company _____

Contact Person _____ Telephone _____

Do not write in this space		
Qualified []	Not qualified []	EMR information verified []

**SAFETY PROGRAM QUALIFICATION CRITERIA
Recordable Incident Rate (RIR)**

The following information will be used to determine if you meet the minimum safety requirements for this project. To qualify, you must not have a three-year average Recordable Incident Rate greater than **7.0**. Incident rate information is on your OSHA Log 300. Please calculate the RIR for the last three complete years as follows. This form shall be submitted by the primary contractor and first tier subcontractors.

$$\frac{\text{Total number of recordable incidents} \times 200,000}{\text{Total employees hours worked}} = \text{RIR}$$

Year	Number of Recordable Incidents	Total Employee Hours Worked	Recordable Incident Rate (RIR)
20 _____	_____	_____ hrs.	RIR = _____
20 _____	_____	_____ hrs.	RIR = _____
20 _____	_____	_____ hrs.	RIR = _____
Three Year Average RIR = _____			

Company Name _____

Contact Name _____ Telephone _____

To verify the above information, we will contact your workers' compensation insurance carrier. Please authorize your carrier to release this information. Failure to do so will result in automatic disqualification.

Workers' Compensation Insurance Company _____

Contact Person _____ Telephone _____

Qualified []	Do not write in this space Not qualified []	RIR information verified []
----------------------	---	-------------------------------------

**SAFETY PROGRAM QUALIFICATION CRITERIA
Lost Time Incident Rate (LTIR)**

The following information will be used to determine if you meet the minimum safety requirements for this project. To qualify, you must not have a three-year average Lost Time Incident Rate greater than **3.5**. Incident rate information is on your OSHA Log 300. Please calculate the LTIR for the last three complete years as follows. This form shall be submitted by the primary contractor and first tier subcontractors.

$$\frac{\text{Total number of lost-time incidents} \times 200,000}{\text{Total employees hours worked}} = \text{LTIR}$$

Year	Number of Lost-time Incidents	Total Employee Hours Worked	Lost Time Incident Rate (LTIR)
20 _____	_____	_____ hrs.	LTIR = _____
20 _____	_____	_____ hrs.	LTIR = _____
20 _____	_____	_____ hrs.	LTIR = _____
Three Year Average			LTIR = _____

Company Name _____

Contact Name _____ Telephone _____

To verify the above information, we will contact your workers' compensation insurance carrier. Please authorize your carrier to release this information. Failure to do so will result in automatic disqualification.

Workers' Compensation Insurance Company _____

Contact Person _____ Telephone _____

Qualified []	Do not write in this space Not qualified []	LTIR information verified []
---------------	---	-------------------------------

(This page left blank intentionally)

BOND OF FAITHFUL PERFORMANCE
(For Successful Bidder)

KNOW ALL MEN BY THESE PRESENTS, that, WHEREAS, Stege Sanitary District, 7500 Schmidt Lane, El Cerrito, California 94530-0530 has awarded to _____ hereinafter designated as the "Principal," a contract for the STANDARD SEWER REHABILITATION PROJECT NO. 12201 – JULY 2012.

WHEREAS said Principal is required under the terms of said contract to furnish a bond for the faithful performance of said contract:

NOW, THEREFORE, WE the principal, and _____ as Surety, are held and firmly bound unto the Stege Sanitary District, State of California, in the penal sum of **one million dollars (\$1,000,000)** lawful money of the United States, for the payment of which sum well and truly to be made, we bind ourselves, our heirs, executors, administrators and successors, jointly and severally, firmly by these presents.

THE CONDITION OF THIS OBLIGATION IS SUCH that if the above bounden Principal, his or its heirs, executors, administrators, successors, or assigns, shall in all things stand to and abide by, and well and truly keep and faithfully perform the covenants, conditions and agreements in the said contract and any alterations made as therein provided, on his or their part, to be part, to be kept and performed at the time and in the manner therein specified, and in all respects according to their true intent and meaning, and shall indemnify and save harmless Stege Sanitary District, its Directors, officers and agents as therein stipulated, then this obligation shall become null and void; otherwise it shall be and remain in full force and virtue and Principal and Surety, in the event suit is brought on this bond, will pay to Stege Sanitary District such reasonable attorney's fees as shall be fixed by the court.

As a condition precedent to the satisfactory completion of the said contract, the above obligation in said amount shall hold good for a period of one (1) year after the completion and acceptance of the said work, during which time if the above bounden Principal, his or its heirs, executors, administrators, successors or assigns shall fail to make full, complete and satisfactory repair and replacements or totally protect Stege Sanitary District from loss or damage made evident during said period of one (1) year from the date of acceptance of said work, and resulting from or caused by defective materials or faulty workmanships in the prosecution of the work done, the above obligation in the said sum shall remain in full force and effect. However, nothing in this paragraph to the contrary notwithstanding, the obligations of the Surety hereunder shall continue so long as any obligation of the Principal remains.

And the said Surety, for value received, hereby stipulates and agrees that no change, extension of time, alteration or addition to the terms of the contract or to the work to be performed there under or to the specifications accompanying the same, shall in any way affect its obligations on this bond, and it does hereby waive notice of any such change, extension of time, alternation or addition to the terms of the contract or to the work or to the specifications.

IN WITNESS WHEREOF the bounden parties have executed this instrument under their seals this _____ day of _____, 20____, the name and corporate seal of each corporate party being hereto affixed and these presents duly signed by its undersigned representative, pursuant to authority of its governing body.

(Seal)

By:

Principal

(Seal)

By:

Surety

LABOR AND MATERIAL BOND

(For Successful Bidder)

KNOW ALL MEN BY THESE PRESENTS, that, WHEREAS, Stege Sanitary District, 7500 Schmidt Lane, El Cerrito, California 94530-0530, has awarded to _____ hereinafter designated as the "Principal," a contract for the STANDARD SEWER REHABILITATION PROJECT NO. 12201 – JULY 2012.

WHEREAS said Principal is required to furnish a bond in connection and with said contract, providing that if said Principal or any of his or its subcontractors, shall fail to pay for any materials provisions, provender, or other supplies or teams used in, upon, for or about the performance of the work contracted to be done, or for any work or labor done thereon of any kind, the Surety of this bond will pay the same to the extent hereinafter set forth:

NOW, THEREFORE, WE the principal, and _____ as Surety, are held and firmly bound unto the Stege Sanitary District, State of California, in the penal sum of **one million dollars (\$1,000,000)** lawful money of the United States, for the payment of which sum well and truly to be made, we bind ourselves, our heirs, executors, administrators and successors, jointly and severally, firmly by these presents.

THE CONDITION OF THIS OBLIGATION IS SUCH that if said Principal, his, or its heirs, executors, administrators, successors, or assigns, shall fail to pay for any materials, provisions, provender, or other supplies or teams used in, upon, for, or about the performance of the work contracted to be done, or for any work or labor thereon of any kind or for amount due under the Employment Act with respect to such work or labor, as required by the provisions of Chapter 7, Title XV, Part 4, Division III of the Civil Code of the State of California, and provided that the persons, companies or corporations so furnishing said materials, provisions, provender or other supplies, teams, appliances or power used, in, upon, of or about the performance of the work contracted to be executed or performed, or any person who supplies both work and materials thereto, shall have complied with the provisions of said Civil Code, then said Surety will pay the same in or to an amount not exceeding the amount hereinabove set forth, and also will pay in case suit is brought upon this bond, such reasonable attorney's fee to Stege Sanitary District as shall be fixed by the court.

The bond shall inure to the benefit of any and all persons, companies, and corporations entitled to file claims under said Civil Code, so as to give a right of action to them or their assigns in any suit brought upon this bond.

And the said Surety, for value received, hereby stipulates and agrees that no change, extension of time, alteration or addition to the terms of the contract or to the work to be performed there under or to the specifications accompanying the same shall in any way affect its obligations on this bond, and it does hereby waive notice of any such change, extensions of time, alteration or addition to the terms of the contract or to the work or to the specifications.

IN WITNESS WHEREOF the bounden parties have executed this instrument under their seals this _____ day of _____, 20____, the name and corporate seal of each corporate party being hereto affixed and these presents duly signed by its undersigned representative, pursuant to authority of its governing body.

(Seal) By: _____
Principal

(Seal) By: _____
Surety

(This page left blank intentionally)

AGREEMENT
(For Successful Bidder)

THIS AGREEMENT, made this _____ day of _____, 20____, by and between the Stege Sanitary District, El Cerrito, California 94530, hereinafter called the "Owner" and _____ hereinafter called the "Contractor".

WITNESSETH:

WHEREAS the Owner has caused specifications, drawings and other contract documents to be prepared for certain work as described therein entitled

**STEGE SANITARY DISTRICT
STANDARD SEWER REHABILITATION PROJECT
PROJECT NO. 12201 – JULY 2012**

WHEREAS the Contractor has offered to perform the proposed work in accordance with the terms of the contract documents.

NOW THEREFORE, in consideration of the mutual covenants and agreements of the parties herein contained and to be performed, the Contractor hereby agrees to complete the work described in the proposal at the price and on the terms and conditions herein contained, and the Owner agrees to pay the Contractor the contract price provided herein at the unit prices shown in the bid proposal for the fulfillment of the work described and the performance of the covenants set forth herein.

The further terms, conditions and covenants of the contract are set forth in the following exhibit parts each of which is attached hereto or referenced and made a part hereof:

- Notice Inviting Sealed Proposals
- Instruction to Bidders
- Proposal
- General Conditions
- Special Conditions
- Technical Conditions
- Drawings
- Issued Addenda to the Contract Documents

IN WITNESS WHEREOF, this agreement has been executed in quadruplicate this _____ day of _____, 20____.

Stege Sanitary District:

Attest: _____

Contractor:

(This page left blank intentionally)

PART II

GENERAL CONDITIONS

STEGE SANITARY DISTRICT
PROJECT NO. 12201
JULY 2012

(This page left blank intentionally)

SECTION 1

DEFINITIONS AND TERMS

G1.01 GENERAL. Whenever the following abbreviations and terms, or pronouns in place of them, appear in the Contract Documents, the intent and meaning shall be interpreted as provided in this Section 1. Working titles having a masculine gender, such as "workman" and "flagman" and the pronoun "he," are utilized for the sake of brevity, and are intended to refer to persons of either sex.

G1.02 DEFINITIONS. As used herein, unless the context otherwise requires, the following terms have the following meaning:

Acceptance: The formal written acceptance by the Owner of an entire contract that has been completed in all respects in accordance with the Contract Documents.

Addenda: Written interpretations or revisions to any of the Contract Documents issued by the Owner before the bid opening.

As Approved: The words "as approved," unless otherwise qualified, shall be understood to be followed by the words "by the Engineer for conformance with the Contract Documents."

As-Built Drawings: Contract plans revised to reflect any modifications resulting during the construction phase.

As Shown and As Indicated: The words "as shown" and "as indicated" shall be understood to be followed by the words "Contract Documents" as appropriate.

Bidder: Any individual, firm, partnership, corporation or combination thereof, submitting a proposal for the work contemplated, acting directly or through a duly authorized representative.

CalTrans: The Department of Transportation, Business & Transportation Agency, State of California.

Contract Change Order: An order authorized by the Owner and issued to the contractor amending the Contract Documents. An "approved Contract Change Order" is an order signed by the Engineer and the General Manager. An "executed Contract Change Order" is an order signed by the Engineer, the General Manager and the Contractor.

Contract: The written agreement covering the performance of the work and the furnishing of labor, materials, tools and equipment in the construction of the work. The Contract shall include the Contract Documents, and any and all supplemental agreements. Supplemental agreements are written agreements covering alterations, amendments or extensions to the Contract and include contract change orders.

Contract Completion: The date the Owner accepts the entire work as being in compliance with the Contract Documents, or formally waives non-conforming work to the extent that non-conforming work does not adversely affect performance of the improvements, and issues the final payment in accordance with Section 9 of the General Conditions.

Contract Documents: The Contract Documents consist of the Notice to Contractors; Instruction to Bidders; Bid Proposal; Agreement; General Conditions; Special Conditions; Technical Conditions; Contract Drawings; Addenda; and Change Orders.

Contractor: The person or persons, firm, partnership, corporation or combination thereof, private or municipal, who enters into the Contract with the Owner.

Contract Drawings: The official plans, profiles, cross sections, elevations, details, and supplemental drawings furnished by the Engineer, which show the locations, character, dimensions and details of the work to be performed. Contract Plans may either be bound in the same book as the balance of the Contract Documents or bound in separate

sets, and are a part of the Contract Documents regardless of the method of binding. Also referred to as "Contract Plans," "Plans," and "Drawings."

Days: Unless otherwise designated, "days" will be understood to mean calendar days.

Engineer: The person or organization identified as such in the Contract Documents, acting directly for the Owner and within the scope of the particular duties delegated to him.

Engineer's Estimate: The list of estimated quantities of work to be performed as contained in the Proposal Form.

Federal Agencies: Whenever, in the Specifications, reference is made to any Federal agency or officer, such reference shall be deemed made to any agency or officer succeeding, in accordance with law, to the powers, duties, jurisdiction and authority of the agency or officer mentioned.

Fixed Costs: Any necessary labor, material and equipment costs directly expended on the item or items under consideration which remain constant regardless of the quantity of the work done.

General Notes: The written instructions, provisions, conditions or other requirements appearing on the Contract Drawings, and so identified thereon, which pertain to the performance of the work.

Inspector/Construction Manager: The engineering or technical inspector(s) duly authorized or appointed by the Engineer or Owner, limited to the particular duties entrusted to him or them.

Legal Holidays: Those days designated as State holidays by the Public Contract Code or declared by the Owner.

Liquidated Damages: The amount prescribed in the Contract Documents to be paid to the Owner or to be deducted from any payments due or to become due the Contractor.

Notice to Proceed: A written notice given by the Owner to the Contractor fixing the date on which the Contract time will commence to run and on which the Contractor shall start to perform his obligation under the Contract Documents.

Or Equal: The term "or equal" shall mean that the "equal" product is the same or better than the product named in function, performance, reliability, quality and general configuration. Determination of equality in reference to the project design requirements will be made by the Engineer. Such equal products shall not be purchased or installed by the Contractor without written acknowledgment of the Engineer.

Owner: As described in the Contract Documents, shall be the Stege Sanitary District or any person or persons to whom the power belonging to the Owner shall be duly delegated.

Plans: Refer to Contract Drawings.

Professional Engineer: An engineer licensed by the Board of Registration for Professional Engineers, State of California.

Proposal: The offer of the bidder for the work, when made out and submitted on the prescribed proposal form, properly signed and guaranteed.

Proposal Form: The approved form upon which the Owner requires formal bids be prepared and submitted for the work.

Proposal Guaranty: The cash, cashier's check, certified check or bid bond accompanying the proposal submitted by the bidder, as a guaranty that the bidder will enter into a contract with the Owner for the performance of the work, if the Contract is awarded to him.

Provide: The term "provide" shall be understood to mean "furnish and install, complete and in place."

Record Drawings: Contract plans revised to reflect any modifications resulting during the construction phase.

Responsive: A "responsive" Proposal is one that complies with the requirements prescribed herein for Proposals.

Special Conditions: The Special Conditions are specific clauses setting forth conditions or requirements of the work and supplementary to these General Conditions. Also referred to as "Supplementary Conditions."

Specifications: The term "Specifications" refers to those portions of the Contract Documents consisting of written technical descriptions of materials, equipment, construction systems, standards, and workmanship as applied to the work and certain administrative details applicable thereto. Where standard specifications, such as those of ASTM, AASHTO, etc., have been referred to, the applicable portions of such standard specifications shall become a part of these Contract Documents. If referenced specifications conflict with Specifications contained herein, the requirements contained herein shall prevail.

Standard Specifications: State of California Department of Transportation Standard Specifications dated July, 1995 or as superseded by newer editions.

State: The State of California.

Work: The word "work" includes all material, labor, tools, and all appliances, machinery, transportation, and appurtenances necessary to perform and complete the Contract, and such additional items not specifically indicated or described which can be reasonably inferred as belonging to the item described or indicated and as required by good practice to provide a complete and satisfactory system or structure.

Work site: The area of actual construction and the areas immediately adjacent thereto.

G1.03 ABBREVIATIONS. As used herein, unless the context otherwise requires, the following abbreviations have the following meanings:

AAMA	Architectural Aluminum Manufacturers' Association
AAN	American Association of Nurserymen
AASHTO	American Association of State Highway and Transportation Officials
ACI	American Concrete Institute
AGA	American Gas Association
AIA	American Institute of Architects
AIEE	American Institute of Electrical Engineers
AISC	American Institute of Steel Construction
AISI	American Iron and Steel Institute
AITC	American Institute of Timber Construction
AMCA	Air Movement and Control Association
ANSI	American National Standards Institute
APA	American Plywood Association
APWA	American Public Works Association
API	American Petroleum Institute
AREA	American Railway Engineering Association
ARI	American Refrigeration Institute
ASA	American Standards Association
ASHRAE	American Society of Heating, Refrigeration and Air Conditioning Engineers
ASME	American Society of Mechanical Engineers
ASTM	American Society for Testing and Materials
AT&T	American Telephone and Telegraph
AWG	American Wire Gage
AWPA	American Wood Preservers' Association
AWS	American Welding Society
AWWA	American Water Works Association

CS	Commercial Standards (US Department of Commerce)
CSI	Construction Specifications Institute
DOT	United States Department of Transportation
EIA	Electronic Industries Association
EPA	Environmental Protection Agency
FGMA	Flat Glass Marketing Association
FHwA	Federal Highway Administration
FM	Factory Mutual
FS	Federal Specification
IAMPO	International Association of Mechanical and Plumbing Officials
ICBO	International Conference of Building Officials
IEEE	Institute of Electrical and Electronics Engineers
NAAMM	National Association of Architectural Metal Manufacturers
NBFU	National Board Fire Underwriters
NEC	National Electrical Code
NEMA	National Electrical Manufacturers' Association
NFC	National Fire Code
NFPA	National Fire Protection Association
OSHA	Occupational Safety and Health Administration
PEI	Porcelain Enamel Institute
PG&E	Pacific Gas and Electric Company
PS	Product Standard (US Department of Commerce)
PacBell	Pacific Bell
SAE	Society of Automotive Engineers
SCPO	Structural Clay Products Institute
SMACNA	Sheet Metal and Air Conditioning Contractors' National Association
SSPC	Steel Structures Painting Council
TCA	Tile Council of America
TPI	Truss Plate Institute
UBC	Uniform Building Code
UL	Underwriters Laboratory
UMC	Uniform Mechanical Code
UPC	Uniform Plumbing Code
WCLIB	West Coast Lumber Inspection Bureau
WIC	Woodwork Institute of California
WWPA	Western Wood Products Association

SECTION 2

PROPOSAL REQUIREMENTS

G2.01 OBTAINING PROPOSAL FORMS. Proposal forms and other bid documents may be obtained from the Owner or Engineer.

G2.02 ENGINEER'S ESTIMATE. If an Engineer's Estimate of quantities is given in the Proposal, the quantities are approximate only, being given as a basis for the comparison of bids. The Owner does not, expressly or by implication, agree that the actual amount of work will correspond to the estimate. The Owner reserves the right to increase or decrease the amount of any class or portion of the work or to omit portions of the work.

G2.03 EXAMINATION OF CONTRACT DOCUMENTS AND SITE OF WORK. The bidder shall examine carefully the Contract Documents and the site of work and shall inform himself of the conditions relating to the execution of the work. Failure to do so will not relieve the successful bidder of his obligation to enter into a Contract and complete the work in strict accordance with the Contract Documents. "Conditions relating to the execution of the work" include the requirements of federal, state and local laws, statutes and ordinances relative to the execution of the work, including, but not limited to, applicable regulations concerning minimum wage rates, non-discrimination in the employment of labor, protection of public and employee health and safety, and environmental protection. The submission of a Proposal shall be conclusive evidence that the bidder has investigated and is satisfied as to the conditions to be encountered, the character, quality and scope of work to be performed, the quantities of materials to be furnished and the requirements of the Contract Documents.

G2.04 SURFACE TOPOGRAPHY; SUBSURFACE CONDITIONS DATA. Where an investigation of surface topography and/or subsurface conditions has been conducted in areas where work is to be performed, prospective bidders may inspect the records of such investigations at the Owner's office.

G2.05 EXPLANATIONS. Any explanation of the Contract Documents desired by a prospective bidder shall be requested in writing from the Engineer, and delivered to Owner no less than 14 calendar days prior to the date for opening of proposals. Any explanation, instruction, or change to Contract Documents will be made by written addendum, which will be mailed or delivered to each firm receiving a set of the Contract Documents. Upon mailing or delivery, such addendum will become a part of Contract Documents and binding on all bidders. The receipt of the addendum by the bidder shall be acknowledged and so noted in the space provided on the Proposal Form. All addenda shall be attached to the Proposal. Only written explanations, instructions or changes so given by the Owner will be effective. Verbal explanations or instructions will not be binding on the Owner.

G2.06 PREPARATION OF PROPOSALS. The form of Proposal in this book, when filled out and executed by the bidder, shall be submitted as his bid. Bids not presented on such forms will be disregarded.

All blank spaces in the Proposal form must be filled in, as required, preferably in black ink. All price information shall be shown, clearly legible, in both words and figures, where required. No changes shall be made in the phraseology of the forms. Written amounts shall govern in the case of discrepancy between the amounts stated in writing and the amounts stated in figures. In case of discrepancy between unit prices and extended totals, unit prices shall prevail.

The bid submitted must not contain any erasure, interlineations, or other corrections unless each correction is suitably authenticated by affixing in the margin immediately opposite the correction the signature or signatures of the person or persons submitting the bid.

The bidder shall sign his Proposal in the blank space provided therefor. If bidder is the sole owner, the owner shall sign the Proposal. If bidder is a corporation, the legal name of the corporation and its State of incorporation shall be set forth above and the Proposal shall be signed by the officer or officers authorized to sign contracts on behalf of the corporation. If bidder is a partnership, the true name of the firm shall be set forth above, the names and addresses of all partners shall be given and a partner in the firm shall sign the Proposal authorized to sign contracts on behalf of the partnership. If the bidder is a joint venture, the Proposal shall be signed by each participating company by

officers or other individuals who have the full and proper authorization to do so. If the Proposal is signed by an agent of the bidder other than an officer of a corporation or a member of a partnership, a notarized power-of-attorney must be on file with the Owner prior to opening of Proposals or must be submitted with the Proposal. If requested by the Owner, the bidder shall promptly submit evidence satisfactory to the Owner of the authority of the person signing the Proposal.

G2.07 SUBMISSION OF PROPOSALS. All Proposals must be submitted not later than the time prescribed, at the place, and in the manner set forth in the Notice to Contractors. Proposals may be made on the separate Proposal forms provided herewith. Any Proposal received after the prescribed time shall be rejected, regardless of whether or not Proposals are opened exactly at the prescribed time.

Each Proposal must be submitted in a sealed envelope. The envelope must be clearly marked to show the bidder's name and the Contract name, without being opened, and be addressed in conformance with the instructions in the Notice to Contractors.

G2.08 LIST OF SUBCONTRACTORS. The bidder shall submit with his Proposal, on the List of Subcontractors provided, the names and business addresses of each subcontractor who will perform work under this Contract in excess of ½ of 1 percent of the amount of the total Proposal, and shall list the portion of the work which will be done by each such subcontractor. If the bidder fails to specify a subcontractor for any portion of the work, the bidder agrees to perform that portion of the work himself, and represents that he is qualified to perform that portion of the work himself.

G2.09 PROPOSAL GUARANTY. The proposal shall be accompanied by a proposal guaranty bond duly completed on the form bound herewith, by a corporation which is listed in the latest Form 356 of the United States Treasury Department as being acceptable as surety on Federal bonds and is duly licensed and admitted by the State of California to be a surety insurer in the State, in the sum of at least twenty (20) percent of the total bid amount as described in the bidding schedule and/or other parts of the contract documents; or alternatively there is attached a certified or cashier's check payable to the Owner in the amount of at least twenty (20) percent of the total bid amount.

The amount payable to the Owner under the proposal guaranty bond, or the certified or the cashier's check and the amount thereof, as the case may be, shall be forfeited to the Owner as liquidated damages in case of a failure or neglect of the bidder to furnish, execute and deliver to the Owner the required performance bond, labor and material bond, evidence of insurance, and to enter into, execute and deliver to the Owner the agreement on the form provided herewith within 10 days after being notified in writing by the Owner that the award has been made and the agreement is ready for execution.

G2.10 WITHDRAWAL OF PROPOSALS. A bidder may withdraw his Proposal at any time prior to the time fixed in the Notice to Contractors for the opening of bids only by filing a written notice with the Owner. The notice shall be executed by the bidder in conformance with Section G2.06. A telegraphic notice of withdrawal is not effective. Withdrawal of a Proposal does not prejudice the right of a bidder to submit a new Proposal. No Proposal may be withdrawn after the time for opening of Proposals, unless and until the time specified in Section G3.02, Time of Award has elapsed.

G2.11 PUBLIC OPENING OF PROPOSALS. Proposals will be opened and read aloud publicly at the date, time and place designated in the Notice to Contractors Inviting Sealed Proposals. Bidders and their authorized representatives are invited to be present.

G2.12 REJECTION OF PROPOSALS, The OWNER may make such investigations as deemed necessary to determine the ability of the Bidder to perform the work, and the Bidder shall furnish to the OWNER all such information and data for this purpose as the OWNER may request.

The OWNER reserves the right to reject any Bid if the evidence submitted by, or investigation of such Bidder fails to satisfy the OWNER that such Bidder is properly qualified to carry out the obligations of the Agreement and to complete the work contemplated therein.

The Owner reserves the right to reject any and all proposals and to waive any informality in any proposal or bid.

G2.13 LICENSING OF BIDDERS. Bidders and their proposed subcontractors shall hold such licenses as may be required by the laws of the State of California for the performance of the work specified in the Contract Documents.

G2.14 ENGINEER OF WORK: The Engineer for the project is Paul Soo, Jr. The Engineer can be reached via the District Office, whose address is 7500 Schmidt Lane, El Cerrito, CA 94530, telephone (510) 524-4668, fax: (510) 524-4697.

(This page left blank intentionally)

SECTION 3

AWARD AND EXECUTION OF CONTRACT

G3.01 AWARD OF CONTRACT. The Owner reserves, in its sole discretion, the right to reject any or all Proposals and to waive any informalities and irregularities in Proposals received, other conditions in the Contract Documents notwithstanding.

The Proposals will be compared on the basis of Contract Total Bid Price. The Total Bid Price is the sum of the lump sum bid items and, for unit price items, the sum of the products of the Engineer's Estimate of quantities shown in the Proposal multiplied by the unit bid price. In the event of a discrepancy between the unit bid price and the extension price, the unit price shall govern.

The award of the Contract, if it were awarded, will be made to the lowest responsible, responsive bidder or bidders.

G3.02 TIME OF AWARD. Within one-hundred twenty (120) days after the opening of Proposals, the Owner will either reject all Proposals or award the Contract to the lowest responsible, responsive bidder. If the lowest responsible, responsive bidder refuses or fails to execute the Contract and provide an acceptable Performance Bond, Labor and Material Bond and insurance certificate(s), the Owner may award the Contract to the second lowest responsible, responsive bidder. Such award, if made, will be made within one-hundred twenty (120) days after the opening of Proposals. If the second lowest responsible, responsive bidder refuses or fails to execute the Contract and provide an acceptable Performance Bond, Labor and Material Bond and insurance certificate(s), the Owner may award the Contract to the third lowest responsible, responsive bidder. Such award, if made, will be made within one-hundred-twenty (120) days after the opening of Proposals. The periods of time specified above within which an award of Contract may be made shall be subject to extension for such further period as may be agreed upon in writing by the Owner and the bidder or bidders concerned.

G3.03 EXECUTION OF CONTRACT. The successful bidder shall, within ten (10) days after having received notice that the Contract has been awarded, sign and deliver to the Owner a Contract in the form hereto attached together with the Performance Bond, Labor and Material Bond and insurance certificate(s) executed as required in the Contract Documents. Within sixty (60) days after receiving the signed Contract with acceptable bonds and insurance certificates from the successful bidder, the Owner will sign the Contract.

G3.04 CONTRACT BONDS. The Contractor shall furnish two bonds each in the amount of one million dollars (\$1,000,000) as security for the faithful performance of the work, and the other as security for the faithful payment and satisfaction of all persons furnishing materials and performing labor on the work. The Contractor shall use the bond forms found at pages BP.21 and BP.23 of these contract specifications. However, the scope of the bonds or the bond forms prescribed in those pages shall in no way affect or alter the liabilities of the Contractor to the Owner under Section G7.21.

The bonds shall be issued by a corporation which is listed in the latest Form 356 of the United States Treasury Department as being acceptable as surety on Federal bonds and is duly licensed and admitted by the State of California to be a surety insurer in the State.

Notwithstanding the language of the preceding paragraph, Owner may disqualify the Contractor's proposed surety if the Owner has cause to believe the surety is likely to be incapable of fulfilling its obligations under the bonds.

The bonds shall remain in force throughout the period required to complete the work and thereafter for a period of three-hundred sixty-five (365) days after final completion and acceptance of the work by the Owner to cover any defects in workmanship, materials, or equipment which develop in that time.

G3.05 FAILURE TO EXECUTE CONTRACT. Failure of a bidder to whom the Contract is awarded to execute the Contract or furnish acceptable Performance Bond, Labor and Material Bond and insurance certificate(s) within ten (10) days of delivery of Notice of Award to bidder shall be just cause for the annulment of the award and the forfeiture of such bidder's Proposal Guaranty. The Proposal Guaranty shall be retained by the Owner as

liquidated damages and it is agreed that this sum is a fair estimate of the amount of damages the Owner will sustain in case the successful bidder fails to enter into a Contract.

G3.06 RETURN OF PROPOSAL GUARANTY. Upon inspection and comparison of Bid prices by the Owner, the Owner will return the Proposal Guaranties of all except the three lowest responsive, responsible Bidders for the Contract. Retained Proposal Guaranties will be held until one-hundred-twenty (120) days after opening of Proposals or until the Contract has been executed, whichever occurs first, after which all Proposal Guaranties other than those that have been forfeited shall be returned. The Proposal Guaranty of the successful Bidder will be retained until the performance bond and labor and material bond have been executed and approved, after which it will be returned.

SECTION 4

SCOPE OF WORK

G4.01 INTENT OF CONTRACT DOCUMENTS. The Contract Documents are complementary, and what is called for by one shall be as binding as if called for by all. The intent of the Contract Documents is to describe a functionally complete project (or part thereof) to be constructed in accordance with the Contract Documents. When the Contract Documents describe portions of the work in general terms, but not in complete detail, it is understood that the best general practice shall be followed and only materials and workmanship of the best standard quality shall be used. Any work, materials or equipment that may reasonably be inferred from the Contract Documents as being required to produce the intended result shall be supplied, whether or not specifically called for. When words, which have a well-known technical or trade meaning are used to describe work, materials or equipment, such words shall be interpreted in accordance with that meaning.

Reference to standard specifications, manuals or codes of any technical society, organization or association, or to the laws or regulations of any governmental authority, whether such reference be specific or by implication, shall mean the latest standard specification, manual, code or laws or regulations in effect on the first published date of the Notice to Contractors, except as may be otherwise specifically stated. However, no provision of any referenced standard specification, manual or code (whether or not specifically incorporated by reference in the Contract Documents) shall be effective to change the duties and responsibilities of Owner or Contractor, or any of their consultants, agents or employees from those set forth in the Contract Documents, nor shall it be effective to assign to Owner, or any of Owner's consultants, agents or employees, any duty or authority to supervise or direct the furnishing or performance of the work or any duty or authority to undertake responsibility contrary to the other conditions of the Contract Documents.

The Contract Documents are divided into parts, divisions and sections for convenient organization and reference. Generally, there has been no attempt to divide the specification sections into work performed by the various building trades, work by separate subcontractors, or work required for separate facilities in the project.

G4.02 EXAMINATION AND VERIFICATION OF CONTRACT DOCUMENTS. The Contractor shall thoroughly examine and become familiar with all of the various parts of these Contract Documents and determine the nature and location of the work, the general and local conditions, and all other matters that can in any way affect the work under this Contract. Failure to make an examination necessary for this determination shall not release the Contractor from the obligations of this Contract. No oral agreement or conversation with any officer, agent or employee of the Owner, or with the Engineer either before or after the execution of this Contract, shall affect or modify any of the terms or obligations herein contained.

G4.03 CHANGES; CONTRACT CHANGE ORDER. The Owner may, without notice to the sureties, and without invalidating the Contract, at any time make alterations, deviations, additions to or deletions from the Contract Documents, and may increase or decrease the quantity of any item or portion of the work, or delete any item or portion of the work, and may require extra work, as determined by the Owner to be necessary or advisable. All such work shall be performed under applicable conditions of the Contract Documents, unless specifically provided otherwise at the time the change is ordered.

Any such changes will be set forth in a written Contract Change Order issued by the Owner. The Contract Change Order will specify: (1) the work to be done in connection with the change to be made; (2) the amount of the adjustment of the Contract price, if any, and the basis for compensation for the work ordered; and (3) the extent of the adjustment in the Contract time, if any. A Contract Change Order shall not become effective until the Engineer and the Owner have signed it; when signed by both the Engineer and the Owner, it is an "approved Contract Change Order."

No changes or deviations from the Contract Documents shall be made without the authority of an approved Contract Change Order, except that in cases of emergency the Engineer may direct a change in writing. Upon receipt of such written directive, the Contractor shall proceed with the ordered work and the Engineer will prepare a written Contract Change Order for approval by the Owner and issuance to the Contractor as soon thereafter as practicable.

Compensation for Emergency Work shall be determined on a time and materials basis.

Upon receipt of an approved Contract Change Order, the Contractor shall sign approved Contract Change Order and promptly proceed with the ordered work, unless otherwise provided in the approved Contract Change Order.

When ordered by the Engineer, the Contractor shall halt work in the area affected by a proposed change. Whenever it appears to the Contractor that a change is necessary, the Contractor shall immediately notify the Engineer of the change he believes necessary and the reasons for such change; however, work in the area affected shall not be discontinued unless ordered by the Engineer.

G4.04 REQUEST FOR QUOTATIONS FOR CHANGE IN WORK. Owner may request Contractor to provide quotations for performing proposed changes to the work. Such requests for quotations shall not be considered authorization to proceed with the change prior to issuance of an approved Contract Change Order, nor shall such request justify any delay in executing existing work. Contractor shall, upon such a request, provide quotations for increases or decreases in the Contract Price and the Contract time associated with performing the proposed change. Quotations shall include substantiating documentation with an itemized breakdown of Contractor and Subcontractor costs, including labor, materials, rentals, services, overhead and profit. The cost of preparing such quotations is included in the Contract price and Contractor shall not be entitled to any additional compensation for preparing them.

G4.05 PROPOSED CONTRACT CHANGE ORDER. A Contract Change Order may be presented to the Contractor for his consideration prior to its having been signed by the Owner. If the Contractor accepts the terms and conditions of such proposed Contract Change Order, and if the Contract Change Order is thereafter signed by the Owner and issued to the Contractor, the Contract Change Order shall be considered to be an executed Contract Change Order for all purposes to the same extent as if the Contract Change Order had been initially issued to the Contractor as an approved Contract Change Order. The Owner need not present a proposed Contract Change Order to the Contractor for his review prior to issuing it as an approved Contract Change Order.

G4.06 EXECUTED CONTRACT CHANGE ORDER. An approved Contract Change Order, which has been signed by the Contractor, is an "executed Contract Change Order." Compensation paid pursuant to Contract Change Orders shall comprise the total compensation for the work described in the Contract Change Order. By signing the Contract Change Order, the Contractor agrees that the specified compensation constitutes full compensation for the work or change, including payment for interruption of schedules, extended overhead, delay or any other "impact" claim or "ripple effect" claim, and by signing, the Contractor specifically waives any reservation or claim for additional compensation in respect to the Contract Change Order.

G4.07 CONTRACT PRICE ADJUSTMENT. If a Contract Change Order provides for an adjustment to the Contract price, the increased payment to Contractor, or the deduction to the credit of the Owner, shall be determined by one of the following methods, or a combination thereof, as determined by the Owner and at its sole option:

A. Unit Prices. The unit prices set forth in the Proposal shall be utilized where they are applicable. If the Contract Change Order increases or decreases the quantity of an item of work by more than twenty-five percent (25%), such that the application of unit prices in the Proposal will cause substantial inequity to the Owner or Contractor, unit prices for quantities in excess of the original bid quantities will be adjusted by mutual agreement. Unit prices for new items included in the Contract Change Order shall be as mutually agreed upon.

Payment for any contract item of work which has a final total value of less than five percent of the total contract bid price will be made at the contract unit price regardless of increased or decreased quantities.

B. Lump Sum. A total lump sum addition or deduction from the Contract Price as mutually agreed upon.

Lump sum quotations for changes to the work shall include substantiating documentation with an itemized breakdown of Contractor and Subcontractor costs, including labor, materials, equipment rental, approved services, overhead and profit, all calculated as set forth in Section G9.03, "Force Account Payment."

C. Force Account Payment. Payment for the work will be made on a time and expense basis, that is, on an accounting of the Contractor's forces, materials, equipment and other items of cost as required to do the work.

If compensation for work done under a Contract Change Order is to be made on a force account basis, the compensation will be calculated as set forth in Section G9.03, "Force Account Payment." Contractor agrees that the markups provided in Section G9.03 are adequate.

In any case in which the method of payment cannot be agreed upon prior to the beginning of the work, the Owner may direct that the work be done on a force account basis.

G4.08 PROTEST PROCEDURE. If the Contractor disagrees with any terms or conditions set forth in an approved Contract Change Order, which he has not executed, he shall submit a written protest to the Engineer within fifteen (15) days after receipt of such approved Contract Change Order. The protest shall state the points of disagreement, Contract Document references, and quantities and costs involved and shall propose a modification of the items with which he does not agree. If a written protest is not submitted within this fifteen (15) day period, payment will be made as set forth in the approved Contract Change Order. Approved Contract Change Orders which are not protested within fifteen (15) days will be considered as executed Contract Change Orders and such payment will constitute full compensation for all work included therein or required thereby.

When the protest of an approved Contract Change Order relates to compensation, the Contractor shall keep full and complete records of such work and shall permit the Owner and the Engineer to have access to all records relating to the protested Contract Change Order to determine the compensation payable. The Contractor shall cooperate with the Engineer to reach agreement at the earliest practical date on the terms of compensation for the Contract Change Order. When agreement has been reached, a revised Contract Change Order may be approved by the Owner and issued to the Contractor for signature. Unless and until the Owner and Contractor agree upon other terms of compensation incorporated in a revised executed Contract Change Order, the compensation shall be as specified under the protested approved Contract Change Order.

When the protest of an approved Contract Change Order relates to the adjustment of Contract Time for the completion of the work, the time will be determined in accordance with the conditions of Section G8.12.

G4.09 CONTINUANCE OF CONSTRUCTION. Disagreement by the Contractor with the Owner's determination of the need for, or amount of, an adjustment in Contract price or Contract time associated with an approved Contract Change Order (or disagreement by the Contractor with the Owner's determination that a change has not occurred and no Contract Change Order is needed) shall not, under any circumstances, relieve the Contractor from its obligation to promptly begin and diligently prosecute the work, including the change, as described in the approved Contract Change Order.

G4.10 DETOURS. When required by the Special Conditions, Technical Conditions, or shown on the Contract Plans, or required by responsible public agencies, the Contractor shall construct, maintain and remove detours for the use of public traffic, without additional cost to the Owner, unless separate payment is specified in the Special Conditions or Technical Conditions.

The failure or refusal of the Contractor to construct and maintain detours at the proper time shall be sufficient cause for closing down the work until such detours are in satisfactory condition for use by public traffic.

G4.11 ARCHAEOLOGICAL DISCOVERIES. All articles of archaeological interest, which may be uncovered by the Contractor during the progress of the work, shall be reported immediately to the Engineer. Progress of the Work with respect to said find shall be in accordance with the requirements of the Special Conditions or Technical Conditions to this Contract.

G4.12 PRESERVATION AND CLEANING. The Contractor shall clean up the work at intervals with a minimum frequency of street sweeping of two (2) times per week and at other times as directed by the Engineer.

Before final inspection of the work, the Contractor shall clean the project site, material sites and all ground occupied by him in connection with the work, of all rubbish, excess materials, false work, temporary structures and equipment. All parts of the work shall be left in a neat and presentable condition. Full compensation for final cleaning up will be considered as included in the prices paid for the various Contract items of work and no separate payment will be made therefor.

G4.13 GUARANTY OF WORK. Notwithstanding inspections and acceptance by the Owner of work furnished under this Contract, the Contractor warrants to the Owner for a period of one (1) year from the date of CONTRACT COMPLETION that all materials and equipment furnished under the Contract, including that provided pursuant to Change Orders, will be of good quality and new, that the work will be free from defects in material or workmanship, and that the work will conform to the requirements of the Contract Documents. Work not conforming to these requirements, including substitutions not properly approved and authorized, may be considered defective.

This warranty by the Contractor is in addition to any warranties or guarantees required by the Special Conditions or Technical Conditions for specified items of equipment or materials. This warranty shall be in effect notwithstanding any disclaimers, or limiting or conditional terms contained in such separate warranties furnished by manufacturers or suppliers.

G4.14 CORRECTION OF WORK DURING WARRANTY PERIOD. If, within the warranty period stated in the Performance Bond after the date of final acceptance of the work by the Owner, any of the work is found not to be in accordance with the Contract Documents, specifically including Section G4.13 ("Guaranty of Work") the Contractor shall correct it promptly after written notice from the Owner to do so, and pay for any damage to other property resulting from such non-conforming work. If the Contractor fails to make the repairs or replacements promptly, or in an emergency when delay could cause risk of damage or loss, the Owner may have the non-conforming work removed, replaced or corrected at the expense of the Contractor and his surety. Non-conforming work which is remedied under this Section shall be subject to an extended warranty obligation, identical in terms to that provided by Section G4.13 and this Section after the non-conforming work has been remedied.

Nothing contained in this Section G4.14 shall be construed to establish a period of limitation with respect to other obligations the Contractor may have under the Contract Documents. Establishment of the warranty period stated in the Performance Bond as described in this Section relates only to the specific obligation of the Contractor to correct the work, and has no relationship to the time within which the obligation to comply with the Contract Documents may be sought to be enforced, nor to the time within which proceedings may be commenced to establish the Contractor's liability with respect to the Contractor's obligations other than specifically to correct the work.

SECTION 5

CONTROL OF WORK

G5.01 AUTHORITY OF ENGINEER. The Engineer shall decide all questions which may arise as to the quality or acceptability of materials furnished and work performed and as to the manner of performance and rate of progress of the work; all questions which may arise as to the interpretation of the Contract Documents; all questions as to the acceptable fulfillment of the Contract on the part of the Contractor; and all questions as to compensation. The Engineer shall have authority to reject work which does not conform to the Contract Documents. His decision shall be final and he shall have authority to enforce and make effective such decisions and orders which the Contractor fails to carry out promptly.

G5.02 CONTRACT DRAWINGS. Upon written request, the Owner will furnish to the Contractor for his use, at no expense to the Contractor, five (5) copies of all Contract Documents, including the Contract Drawings. Additional copies may be obtained at cost.

G5.03 SHOP DRAWINGS. The Contract Drawings shall be supplemented by shop drawings furnished by the Contractor. The Engineer shall have reviewed shop drawings before any work involving such drawings is performed or equipment purchased. The Contractor shall make no change in any shop drawing after it has been reviewed by the Engineer and stamped "No Exceptions Taken."

Shop drawing submittals shall contain adequate information to permit the Engineer to evaluate each submission for conformance with the Contract Documents. Each submittal shall be complete; partial submittals will not be reviewed. All drawings shall include a graphical scale and indicate the amount of reduction used, if any. The quality of lettering and draftsmanship shall be such as to insure easily read reproductions by microfilming process.

Each shop drawing submitted by the Contractor shall bear the approval stamp of the Contractor, and shall be marked to indicate any deviation in the shop drawing from the requirements of the Contract Documents. By approving and submitting shop drawings, the Contractor thereby represents that he has determined and verified all field measurements, field construction criteria, materials, catalog numbers and similar data, and that he has checked and coordinated each shop drawing with the requirements of the work and the Contract Documents. Where applicable, shop drawings will be certified for construction by the manufacturer.

Each submittal shall be accompanied by a transmittal letter from the Contractor stating the name of the material or equipment items as shown on the Contract Documents, a specification reference consisting of a section number, and any proposed deviations from the Contract Documents requested or shown on the submittal.

Review of shop drawings is only for general conformance with the design concept of the project and general compliance with the information given in the Contract Documents. Review of the Contractor's shop drawings shall not relieve Contractor of any of his responsibility for the successful completion of the work in conformity with the requirements of the Contract Documents. The Contractor is responsible for conformance with all requirements of the Contract Documents, including, but not limited to, dimensions which shall be conformed and correlated at the job site, fabrication processes and techniques of construction, coordination of work with that of all others, and satisfactory performance of all work. Review of shop drawings shall not waive any requirement of the Contract Documents and defective work may be rejected notwithstanding such review.

It is the Contractor's responsibilities to submit shop drawings and other submittals so as to allow sufficient time for review, and for possible revisions and resubmits. Normal review time by the Engineer shall be thirty (30) calendar days; complex submittals may require up to forty-five (45) days. Contractor shall submit all shop drawings to the Engineer within forty-five (45) days after date of Award of Contract.

Owner will make its best efforts to review submittals within the time period scheduled by the Contractor, provided it is consistent with the time period specified in the preceding paragraph, but the Owner's inability to do so shall not automatically entitle the Contractor to additional time to complete the Contract. If the Engineer fails to complete his review of shop drawing submittals within a reasonable time (not to be less than the time period specified in this

section), and if the Contractor's controlling operation is delayed by reason of the delay in review, an extension of time commensurate with the delay in completion of the work thus caused will be granted pursuant to Section G8.11, but no additional compensation will be allowed for such delay.

Shop drawings reviewed by the Engineer will be returned to the Contractor. The Engineer's action on each submittal will consist of one of the following: "No Exceptions Taken," "Exceptions Taken as Noted," "Revise and Resubmit" or "Rejected." If the Engineer takes exception to any drawings, the Contractor shall make the necessary revisions and resubmit them to the Engineer for review. When shop drawings are required to be resubmitted, the revisions are to be clearly defined on the revised drawings. Resubmits will be reviewed in accordance with the provisions applicable to initial submittals and the time period for the Engineer's review shall be equal to that for initial submittals.

Submittal and processing of shop drawings shall conform to the requirements of the Special Conditions and Technical Conditions.

Full compensation for furnishing all shop drawings shall be considered as included in the prices paid for the Contract items of work to which such drawings relate and no additional compensation will be allowed therefor.

When the shop drawings have been completed to the satisfaction of the Engineer, the Contractor shall carry out the construction in strict accordance therewith. Any further changes will require a resubmits of the drawings.

Contractor shall be charged for the review of submittals for items that have been previously rejected by the Engineer two or more times. Contractor shall be charged for the review of submittals as a result of a request for substitution by the Contractor. The basis for such charges shall be the cost actually incurred by the Owner for the review of the submittal.

G5.04 CONFORMITY WITH CONTRACT DOCUMENTS. Work and materials shall conform to the lines, grades, cross sections, dimensions and material requirements, including tolerances, shown on the Contract Drawings or indicated in the Specifications. Although measurement, sampling and testing may be considered evidence as to such conformity, the Engineer shall be the sole judge as to whether the work or materials deviate from the Contract Drawings and Specifications, and his decision as to any allowable deviations therefrom shall be final.

G5.05 COORDINATION AND INTERPRETATION OF CONTRACT DOCUMENTS. The General Conditions, Special Conditions, Technical Conditions, Contract Drawings, Contract Change Orders and all supplementary documents are essential parts of the Contract, and a requirement occurring in one is as binding as though occurring in all. They are intended to be complementary, and to describe and provide for a complete work.

If there is a conflict between Contract Documents, the document highest in precedence shall control. The precedence shall be:

- A. Permit requirements of the other agencies.
- B. Special Conditions.
- C. Technical Conditions.
- D. Plans.
- E. General Conditions.
- F. Standard Specifications.

Change Orders, Supplemental Agreements and approved revisions to Plans and Specifications will take precedence over Items B through F above.

The Contract Documents of the highest precedence shall in no way nullify non-conflicting portions of the Contract Documents of lower precedence.

In the event of inconsistencies between requirements in the Special Conditions and requirements in the General Conditions, the Special Conditions shall govern.

In case of differences between small and large-scale drawings, the large-scale drawings shall govern. Schedules or

drawings shall take precedence over conflicting notations on drawings. In the event of discrepancy between any drawing and the figures written thereon, the figures, unless otherwise directed, will govern over scaled dimensions.

Should it appear that the work to be done or any of the matters relative thereto is not sufficiently detailed or explained in the Contract Documents, the Contractor shall apply to the Engineer for such further written explanations as may be necessary and shall conform to them as part of the Contract. In the event of any doubt or question arising respecting the true meaning of the Contract Documents, clarification shall be sought from the Engineer, whose decision thereon shall be final.

G5.06 ORDER OF WORK. When required by the Special Conditions or Contract Drawings, the Contractor shall follow the sequence of operations as set forth therein.

Full compensation for conforming to such requirements will be considered as included in the prices paid for the various Contract items of work and no additional compensation will be allowed therefor.

G5.07 SUPERINTENDENCE. The Contractor shall supervise and direct the work using his best skill and attention and shall keep at the project site competent supervisory personnel at all times while work is in progress. The Contractor shall designate, in writing, before starting work, a project superintendent who shall be an employee of Contractor and shall have complete authority to represent and act for the Contractor. The Contractor shall notify the Engineer in writing prior to any change in superintendent assignment.

The Contractor shall be solely responsible for and have control over construction means, methods, techniques and procedures for providing adequate safety precautions and coordinating all portions of the work under the Contract, unless the Contract Documents give other specific instructions concerning these matters.

G5.08 LINES AND GRADES. Only such primary control lines, monuments and bench marks will be set by the Engineer as he determines to be necessary to control establishment of the lines and grades required for the completion of the work. In general, these will consist of the primary horizontal and vertical control points shown on the Contract Drawings. The Contractor shall notify Engineer a minimum of five (5) working days before such stakes or marks are needed.

The Contractor shall carefully preserve monuments, stakes and marks set by the Engineer. If such monuments, stakes or marks are destroyed or damaged, the Engineer at his earliest convenience will replace them. The Contractor shall be charged for the cost of replacing or restoring monuments, stakes and marks destroyed or damaged by reason of his operations. This charge will be deducted from any monies due or to become due the Contractor.

The Contractor shall temporarily suspend work at such points and for such reasonable times as the Engineer may require for transferring or setting monuments, stakes or marks, and the Contractor shall not be entitled to any additional compensation or extension of time therefor.

All other stakes or marks required to establish the lines and grades required for the completion of the work shall be the responsibility of the Contractor. Payment for such work shall be considered as included in the prices paid for the various Contract items of work and no additional compensation will be allowed therefor.

Contractor shall take field measurements and verify field conditions consistent with prudent construction industry standards and shall carefully compare such field measurements and conditions and other information known to Contractor with the Contract Documents before commencing construction activities on the work site. Errors, inconsistencies or omissions in the Contract Documents discovered by Contractor shall be reported to the Engineer at once.

G5.09 INSPECTION. The Engineer, and all authorized representatives of the Owner, shall at all times have safe access to the work during its construction, and shall be furnished with every reasonable facility for ascertaining that the materials and the workmanship are in accordance with the requirements and intentions of the Contract Documents. All work done and all materials furnished shall be subject to the Engineer's on-site and off-site inspection.

The inspection and observation of the work or materials by the Engineer shall not relieve the Contractor of any obligations to fulfill his Contract as prescribed. Work and materials not meeting such requirements shall be corrected, and unsuitable work or material may be rejected, notwithstanding that such work or materials have been previously inspected by the Engineer, or that payment therefor has been included in a progress estimate.

The Engineer may order re-examination of questioned work at any time before final acceptance. If so ordered, the Contractor shall uncover the work. If such work is found to be in accordance with the Contract Documents, the Owner will pay for the cost of uncovering; removal, recovering and replacing of the parts removed; but if such work so exposed or examined is not in accordance with the Contract Documents, the uncovering, removal, recovering and replacement shall be at the Contractor's expense. Work which has been covered prior to observation by the Engineer does not qualify as re-examined work; the Owner may order it uncovered for observation without payment of costs.

The Contractor shall give due notice to the Engineer before backfilling so that the Engineer may observe the materials and installation.

The Contractor shall notify the Engineer in advance as to those times when no construction activities will take place. Absent such notification, all costs incurred by the Owner as a result of attending to the project site at times when no construction is taking place will be charged to the Contractor.

Whenever the Contractor intends to perform work on Saturday, Sunday, or a legal holiday, he shall give notice to the Engineer of such intention twenty-four (24) hours prior to performing such work, or such longer period as may be specified, so that the Engineer may make necessary arrangements.

The observations and inspections performed by the Engineer shall not relieve the Contractor of his responsibility to conduct comprehensive inspections of the work and to furnish materials and perform work in conformance with the Contract Documents.

G5.10 DOCUMENTS ON JOB SITE. The Contractor shall keep one copy of all Contract Documents (including Change Orders), approved Shop Drawings and approved progress payments on the job site, in good order, available to the Engineer and all authorized representatives of the Owner.

G5.11 CORRECTION, REMOVAL OF REJECTED WORK. The Contractor shall promptly correct work rejected by the Engineer as failing to conform to the requirements of the Contract Documents, whether or not fabricated, installed or completed, so that it does comply with the Contract Documents. The Contractor shall bear the costs of correcting such rejected work, including additional testing, inspections and compensation for the Engineer's services and expenses made necessary thereby.

The Contractor shall remove, at his cost, from the site portions of the work which are not in accordance with the Contract Documents or which are not corrected by the Contractor.

The Contractor shall correct, at his cost, damaged or destroyed construction, whether completed or partially completed.

Any work done beyond the lines shown on the Contract Drawings or established by the Engineer, and all extra work done without written authority, will be considered as unauthorized work. Upon order of the Engineer, unauthorized work shall be remedied, removed or replaced at the Contractor's cost.

If the Contractor fails to promptly correct non-conforming or rejected work, or to comply promptly with any order of the Engineer under this Section, the Owner may cause such work to be remedied, removed or replaced and the costs thereof will be deducted from any monies due or to become due the Contractor.

Failure on the part of the Engineer to reject non-conforming work shall not be construed to imply acceptance of such work.

G5.12 EQUIPMENT AND PLANTS. The Contractor shall use or permit only equipment and plants suitable to produce the quality of work and materials required, and meeting all State and Federal safety requirements.

Plants shall be designed and constructed in accordance with general practice for such equipment and shall be of sufficient capacity to insure the production of materials needed to complete the work in accordance with the Contractor's schedule and the Contract time.

When ordered by the Engineer, the Contractor shall remove unsuitable equipment from the work and discontinue the operations of unsafe or unsatisfactory plants.

All equipment used shall be selected such that construction loads do not exceed the bearing capacity of structures, highways, streets, and subsurface conduits. The Contractor's attention is directed to Section G7.08 of these General Conditions.

G5.13 CHARACTER OF WORKERS. The Contractor shall enforce strict discipline and good order among the Contractor's employees and other persons carrying out the Contract. The Contractor shall not permit employment of unfit persons nor persons unskilled in tasks assigned to them. Engineer shall have the authority to require Contractor to remove undisciplined workers from the work.

G5.14 FINAL INSPECTION. When the work has been completed, the Engineer will make the final inspection. The Contractor shall notify the Engineer in writing when it considers the work complete and shall request a final inspection.

G5.15 SUBMITTAL OF AS-BUILT DATA. The Contractor shall submit to the Engineer all information required by the Engineer to verify as-built drawings for all permanent Contract work.

In order to provide for the timely submission of data, and avoid loss of information, the Contractor shall submit acceptable as-built data to the Engineer on a monthly basis.

G5.16 EMERGENCIES. In an emergency affecting the safety of life, the work, or adjoining property, the Contractor, without special instructions or authorization from the Engineer, shall act at his discretion to prevent such threatened loss or injury. In such an emergency, the Contractor shall perform such additional work as is required. Any compensation claimed by the Contractor on account of emergency work shall be determined in accordance with the conditions of Section 9.

(This page left blank intentionally)

SECTION 6

CONTROL OF MATERIALS

G6.01 SOURCE OF SUPPLY AND QUALITY OF MATERIALS. The Contractor shall furnish all materials required to complete the work, except materials that are designated in the Specifications to be furnished by the Owner and materials furnished by the Owner in accordance with force account work as described in Section G9.03. As used in this Section, the term "materials" shall mean materials and equipment furnished for incorporation in the work.

Notwithstanding any prior inspection, only materials conforming to the requirements of the Contract Documents shall be incorporated in the work.

The materials furnished and used shall be new, except as may specifically be provided elsewhere in the Contract Documents. The materials shall be manufactured, handled, and used in a workmanlike manner to ensure completed work in accordance with the Contract Documents.

Whenever it is provided that the Contractor shall furnish materials or manufactured articles, or shall do work, for which no detailed specifications are set forth, the materials or manufactured articles shall be of the best grade in quality and workmanship obtainable in the market from firms of established good reputation; or if not ordinarily carried in stock, shall conform to the usual standards for first-class materials of the kind required, with due consideration for the use they are to be put to.

The Contractor shall submit to the Engineer a list of his sources of materials and the locations at which such materials will be available for inspection. The list shall be submitted in sufficient time to permit proper inspection and testing of materials to be furnished from such listed sources in advance of their use. The Contractor shall assure that the Engineer or his authorized representative has free access at all times to the material to be inspected, sampled or tested. The Engineer may inspect, sample or test materials at the source of supply or other locations. It is understood that such inspections and tests in no way shall be considered as a guaranty of acceptance of such material nor of continued acceptance of material presumed to be similar to that upon which inspections and tests have been made, and that inspection and testing performed by the Owner shall not relieve the Contractor or his suppliers of responsibility for quality control.

Manufacturers' warranties, guaranties, instruction sheets and parts lists, which are furnished with certain materials incorporated in the work, shall be delivered to the Engineer before acceptance of the Contract.

Reports and records of inspections made and tests performed, when available at the site of the work, may be examined by the Contractor and the Engineer.

G6.02 OWNER-FURNISHED MATERIALS. Materials furnished by the Owner will be available at locations designated in the Specifications, or if not designated in the Specifications, they will be available at the Owner's Office. The Contractor, at his own expense, including any necessary loading and unloading that may be involved shall haul them to the site of the work. The cost of handling and placing Owner-furnished material shall be considered as included in the price paid for the Contract item involving such Owner-furnished material.

The Contractor shall be held responsible for all materials furnished to him, and he shall pay all demurrage and storage charges. Owner-furnished materials lost or damaged from any cause whatsoever shall be replaced by the Contractor, at his expense. The Contractor will be liable to the Owner for the cost of replacing Owner-furnished material, and such costs may be deducted from any monies due or to become due the Contractor. All Owner-furnished materials that are not used on the work shall remain the property of the Owner and will be delivered to the Owner's corporation yard.

G6.03 STORAGE OF MATERIALS. Materials shall be stored by the Contractor in such a manner as to ensure the preservation of their quality and fitness for the work and to facilitate inspection.

G6.04 DEFECTIVE MATERIALS. All Contractor-furnished materials not conforming to the requirements of the Contract Documents may be rejected, whether in place or not. They shall be removed immediately from the site of the work unless otherwise permitted by the Engineer. No rejected material, the defects of which have been subsequently corrected, shall be used in the work unless approval in writing has been given by the Engineer. Upon failure of the Contractor to comply promptly with any order of the Engineer made under the conditions of this Section, the Engineer may cause the removal and replacement of rejected material and deducts the cost thereof from any monies due or to become due the Contractor.

G6.05 MATERIAL AND EQUIPMENT SPECIFIED BY NAME. Whenever any material or equipment is specified by two patent or proprietary names or by the names of two manufacturers, such specifications shall be considered as used for the purpose of describing the material or equipment desired and shall be considered as if followed by the words "or acceptable equal", whether or not such words appear. The Contractor may offer material or equipment with equal or better qualities and performance in substitution for those specified which he considers would be in the District's interest to accept. No offers for substitution will be acknowledged or considered from suppliers, distributors, manufacturers or subcontractors. Any such offer shall be made in writing to the District Manager for his consideration within thirty-five days after award of the contract. The Contractor shall include with his offer sufficient data which, together with any other data the District may require, will enable the District to assess the acceptability of the material or equipment. When the substitute equipment or material necessitates changes to or coordination with any other portion of the work, the data submitted shall include drawings and details showing all such changes, and the Contractor shall perform these changes as part of any acceptance of substitute material or equipment. The use of any material or equipment so offered will be permitted only after written acceptance of his offer by the District. Such acceptance by the District shall not relieve the Contractor from full responsibility for the efficiency, sufficiency and quality and performance of the substitute material or equipment, in the same manner and degree as the material and equipment specified by name.

Whenever any material or equipment is specified by only one patent or proprietary name or by the name of only one manufacturer, such material or equipment shall be so specified for the purpose of standardization with existing equipment or materials or has no known equal.

G6.06 PLANT INSPECTION. The Engineer may inspect the production of material, or the manufacture of products, at the source of supply. Plant inspection, however, will not be undertaken until the Engineer is assured of the cooperation and assistance of both the Contractor and the material producer. The Engineer or his authorized representative shall have free entry at all times to such parts of the plant as concern the manufacture or production of the materials. Adequate facilities shall be furnished free of charge to make the necessary inspection. The Engineer assumes no obligation to inspect materials at the source of supply. The responsibility of incorporating satisfactory materials in the work rests entirely with the Contractor, notwithstanding any prior inspections or tests.

G6.07 PRODUCT AND REFERENCE STANDARDS. When descriptive catalog designations, including manufacturer's name, product brand name or model number are referred to in the Contract Documents, such designations shall be considered as being those found in industry publications in effect on the day the Notice to Contractors for the work is dated.

G6.08 SAMPLES. After the award of the Contract, the Contractor shall furnish to the Engineer samples indicated in the Specifications or requested by the Engineer. Samples shall be submitted without charge, with shipping charges prepaid. Materials for which samples are required shall not be used in the work until approved in writing by the Engineer.

Each sample shall be submitted in duplicate unless otherwise directed, and shall be labeled with the following data: name of project; name of Contractor; material represented and location in the project including specification reference; and producer information including brand, model, place of origin, and other pertinent information.

The Contractor shall forward a transmittal letter to the Engineer with each shipment of samples containing the information required in the previous paragraph. Approval of a sample shall be only for the characteristics and use named in the submittal and approval shall not be construed to change or modify any Contract requirement. Before submitting samples, the Contractor shall assure himself that the materials or equipment will be available in the quantities required in the project, as no change or substitution will be permitted after a sample has been approved

unless approved by the Engineer in writing.

Samples of material from local sources shall be taken by or in the presence of the Engineer if so required by the Engineer; otherwise the samples will not be considered for testing.

Approved samples not damaged in testing may be incorporated in the finished work if marked for identification and approved by the Engineer. Materials incorporated in the work shall match the approved samples.

Failure of any material to pass the specified tests will be sufficient cause for refusal to consider under this Contract any further samples of the same brand, make or source of that material. The Engineer reserves the right to disapprove any material which has previously proven unsatisfactory in service.

Samples of material delivered on the site or in place may be taken by the Engineer for testing. Failure of samples to meet Contract requirements will annul previous approvals of the item tested.

G6.09 TESTING OF MATERIALS OR WORK. Materials to be used in the work will be subject to inspection and tests by the Engineer or his designated representative. The Contractor shall furnish, without charge, such samples as may be required.

Materials and work shall be tested in accordance with the methods in use by the State of California, Department of Transportation, or by nationally recognized testing organizations or as specified in the Contract Documents. The Engineer will make or approve all testing. Unless otherwise noted in the Specifications, testing will be made at the expense of the Owner. In the event that any materials and work fail to pass tests, the cost of subsequent testing of similar materials and work as may be required by the Engineer shall be borne by the Contractor.

Test methods developed by the State of California, Department of Transportation are identified by the prefix Calif., followed by the serial number. Copies of individual test methods are available at the Transportation Laboratory, Sacramento, California.

Whenever a reference is made in the Specifications to a test method by California number, it shall mean the test method in effect on the date of the Notice to Contractors for the work. Whenever a reference is made in the Specifications to a specification or test designation of the American Society for Testing and Materials, the American Association of State Highway Officials, Underwriters' Laboratories, Inc., or any other recognized national organization, and the number accompanying the test designation representing the year of adoption of the test has been omitted, the reference shall mean the test method in effect on the date of the Notice to Contractors for the work.

Whenever the Contract Documents provide an option between two or more test methods, the Engineer will determine the test method to be used.

Whenever a specification, manual or test designation provides for test reports (such as certified mill test reports) from the manufacturer, copies of such reports, identified as to the lot of material, shall be furnished to the Engineer. The manufacturer's test report shall supplement the inspection, sampling and testing conditions of this Section and shall not constitute a waiver of the Owner's right to inspect. When material which cannot be identified with specific test reports is proposed for use, the Engineer may, at his discretion, select random samples from the lot for testing. Testing specimens from the random samples, including those required for retest, shall be prepared in accordance with the referenced specification and furnished by the Contractor at his expense. The number of such samples and test specimens shall be entirely at the discretion of the Engineer.

G6.10 CERTIFICATE OF COMPLIANCE. A Certificate of Compliance shall be furnished prior to the use of any materials for which the Special Conditions or Specifications require that such Certificate be furnished. In addition, the Engineer may permit the use of certain materials prior to sampling and testing if accompanied by a Certificate of Compliance stating that the materials involved comply in all respects with the requirements of the Specifications. The Certificate shall be signed by the manufacturer of the material. A Certificate of Compliance shall be furnished with each lot of material delivered to the work and the lots so certified shall be clearly identified in the Certificate.

All materials used on the basis of a Certificate of Compliance may be sampled and tested at any time. The fact that material is used on the basis of a Certificate of Compliance shall not relieve the Contractor of responsibility for incorporating material in the work which conforms to the requirements of the Contract Documents, and any such material not conforming to such requirements will be subject to rejection whether in place or not.

The Owner reserves the right to refuse to permit the use of material on the basis of a Certificate of Compliance.

The form of the Certificate of Compliance and its disposition shall be as approved by the Engineer.

SECTION 7

LEGAL RELATIONS AND RESPONSIBILITIES

G7.01 LAWS TO BE OBSERVED. The Contractor shall keep himself fully informed concerning all requirements of law, including but not limited to all State and Federal laws and county and municipal ordinances and regulations which in any manner affect those engaged or employed in the work, the materials used in the work, or which in any way affect the conduct of the work, and of all such orders and decrees of bodies or tribunals having any jurisdiction or authority over the same. The Contractor shall at all times observe, and shall cause all his agents and employees to observe, all such requirements of laws and shall protect, indemnify and hold harmless the Owner, the Engineer, and all of their respective officers, agents and employees against all claims and liabilities arising from or based on the violation of any such requirement of law whether by the Contractor or his employees. If any discrepancy or inconsistency is discovered in the Contract Documents for the work in relation to any such requirements of laws, the Contractor shall immediately report the same to the Engineer in writing. The Contract Documents shall be governed by the laws of the State of California.

G7.02 LABOR CODE REQUIREMENTS. Attention is directed to the following requirements of the Labor Code:

A. Hours of Labor. Eight hours labor constitutes a legal day's work. The Contractor shall forfeit, as penalty to the Owner, twenty-five (\$25.00) for each workman employed in the performance of the Contract by the Contractor or by any subcontractor under him for each calendar day during which such workman is required or permitted to work more than eight (8) hours in any one day and forty (40) hours in any one calendar week in violation of the provisions of the California Labor Code and in particular, Sections 1810 to 1815 thereof, inclusive, except that work performed by employees of the Contractor in excess of eight (8) hours per day and forty (40) hours during any one week shall be permitted upon compensation for all hours worked in excess of eight (8) hours per day at not less than one-and-one-half (1½) times the basic rate of pay, as provided in said Section 1815.

B. Labor Non-Discrimination. Attention is directed to Section 1735 of the Labor Code which provides the Contractor shall not discriminate against any employee who is employed on the work because of race, religious creed, color, national origin, ancestry, physical handicap, medical condition, marital status, sex or age of such persons, except as provided in Section 12940 of the Government Code.

C. Prevailing Wages. The Contractor shall comply with California Labor Code Sections 1770 to 1780, inclusive. In accordance with said Section 1775, the Contractor shall forfeit as a penalty to the Owner fifty (\$50.00) for each calendar day or portion thereof for each workman paid less than stipulated prevailing wage rates for such work or craft in which such worker is employed for any work done under the Contract by him or by any subcontractor under him in violation of the provisions of the Labor Code and in particular, Labor Code Sections 1770 to 1780, inclusive. In addition to said penalty and pursuant to said Section 1775, the difference between such stipulated prevailing wage rates and the amount paid to each worker for each calendar day or portion thereof for which each worker was paid less than the stipulated prevailing wage rate shall be paid to each worker by the Contractor.

Pursuant to the provisions of Section 1773 of the Labor Code, the Owner has obtained the general prevailing rate of per diem wages and the general prevailing rate for holiday and overtime work applicable to the work to be done from the Director of the Department of Industrial Relations. Copies of the prevailing rates are on file at the Owner Office and are available to any interested party on request. Such wage rates must be prominently posted at the construction site.

The Owner will not recognize any claim for additional compensation because of the payment by the Contractor of any wage rate in excess of the prevailing wage rate set forth in the Contract. The possibility of wage increases is one of the elements to be considered by the Contractor in determining his bid, and will not under any circumstances be considered as the basis of a claim against the Owner on the Contract.

Attention is directed to the requirements of Section 1773.8 of the Labor Code. The Contractor shall make

travel and subsistence payments to each worker needed to execute the work in accordance with the requirements of said Section 1773.8.

D. Payroll Records. The Contractor's attention is directed to the following provisions of Labor Code Section 1776. The Contractor shall be responsible for the compliance with these provisions by his subcontractors.

(a) Each contractor and subcontractor shall keep an accurate payroll record, showing the name, address, social security number, work classification, straight time and overtime hours worked each day and week, and the actual per diem wages paid to each journeyman, apprentice, worker, or other employee employed by him or her in connection with the public work.

(b) The payroll records enumerated under subdivision (a) shall be certified and shall be available for inspection at all reasonable hours at the principal office of the Contractor on the following basis:

(1) A certified copy of an employee's payroll record shall be made available for inspection or furnished to the employee or his or her authorized representative on request.

(2) A certified copy of all payroll records enumerated in subdivision (a) shall be made available for inspection or furnished upon request to the Owner, the Division of Labor Standards Enforcement, and the Division of Apprenticeship Standards of the Department of Industrial Relations.

(3) A certified copy of all payroll records enumerated in subdivision (a) shall be made available upon request to the public for inspection or copies thereof made; provided, however, that a request by the public shall be made through either the Owner, the Division of Apprenticeship Standards, or the Division of Labor Standards Enforcement. If the requested payroll records have not been provided pursuant to paragraph (b)(2), herein, the requesting party shall, prior to being provided the records, reimburse the costs of preparation by the Contractor, subcontractor and the entity through which the request was made. The public shall not be given access to such records at the principal office of the Contractor.

(c) Each contractor shall file a certified copy of the records enumerated in subdivision (a) with the entity that requested the records within ten (10) days after receipt of a written request.

(d) Any copy of records made available for inspection and copies furnished upon request to the public or any public agency by the Owner, the Division of Apprenticeship Standards, or the Division of Labor Standards Enforcement shall be marked or obliterated in such a manner as to prevent disclosure of an individual's name, address, and social security number. The name and address of the Contractor awarded the contract or performing the contract, shall not be marked or obliterated.

(e) The Contractor shall inform the Owner of the location of records enumerated under subdivision (a), including the street address, city and county, and shall, within five (5) working days, provide a notice of a change of location and address.

(f) In the event of noncompliance with the requirements of this Section, the Contractor shall have ten (10) days in which to comply subsequent to receipt of written notice specifying in what respects the contractor must comply with this Section. Should noncompliance still be evident after the ten-day (10) period, the Contractor shall, as a penalty to the State or the Owner, forfeit twenty-five (\$25.00) for each calendar day, or portion thereof, for each worker, until strict compliance is effectuated. Upon the request of the Division of Apprenticeship Standards or the Division of Labor Standards Enforcement, these penalties shall be withheld from progress payments then due. Responsibility for compliance with these Paragraphs (a) through (f) lies with the Contractor.

The penalties specified in subdivision (f) of Labor Code Section 1776 for noncompliance with the provisions of said Section 1776 may be deducted from any monies due or which may become due to the Contractor.

The Contractor and each subcontractor shall preserve their payroll records for a period of 3 years from the date of completion of the Contract.

E. Apprentices. The Contractor shall fully comply with the requirements of Sections 1777.5, 1777.6 and 1777.7 (as amended) of the California Labor Code and the regulations of the California Apprenticeship Council. In accordance with Section 1777.5, the Contractor shall secure the necessary certificates and shall contribute to the apprenticeship fund or funds, as provided for therein. The Contractor shall require each subcontractor who will perform work or labor or render service to the Contractor in or about the construction of the work to comply fully with Sections 1777.5 and 1777.6 of the Labor Code. Information relative to apprenticeship standards, wage schedules and other requirements may be obtained from the State Division of Apprenticeship Standards and its branch offices.

F. Worker's Compensation. Pursuant to the requirements of Section 1860 of the California Labor Code, the Contractor will be required to secure the payment of workers' compensation to his employees in accordance with the provisions of Section 3700 of the Labor code.

Prior to commencement of work, the Contractor shall sign and file with the Owner, a certification in the following form:

"I am aware of the provisions of Section 3700 of the California Labor Code which require every employer to be insured against liability for workers, compensation or to undertake self accordance with the provisions of that code, and I will comply with such provisions before commencing the performance of the work of this contract."

Said certification is included in the Contract, and signature and return of the Contract as provided in Section G3.03, "Execution of Contract," of the General Conditions, shall constitute signing and filing of the said certificate.

G7.03 CONTRACTORS' LICENSING LAWS. Attention is directed to the provisions of Chapter 9 of Division 3 of the California Business and Professions Code concerning the licensing of contractors. All bidders and contractors shall be licensed in accordance with the laws of the State of California and any bidder or contractor not so licensed is subject to the penalties imposed by such laws.

G7.04 AIR POLLUTION CONTROL. The Contractor shall comply with all air pollution control rules, regulations, ordinances and statutes which apply to any work performed pursuant to the Contract, including any air pollution control rules, regulations, ordinances and statutes specified in Section 11017 of the Government Code.

Material to be disposed of shall not be burned, either inside or outside the work site.

G7.05 WATER POLLUTION CONTROL. The Contractor shall exercise every reasonable precaution to protect streams, lakes, reservoirs, bays and coastal waters from pollution with fuels, oils, bitumen, calcium chloride and other harmful materials and shall conduct and schedule his operations so as to avoid or minimize muddying and silting of said streams, lakes, reservoirs, bays and coastal waters. Care shall be exercised to preserve roadside vegetation beyond the limits of construction.

Water pollution control work is intended to provide prevention, control, and abatement of water pollution to streams, waterways and other bodies of water, and shall consist of constructing those facilities which may be shown on the plans, specified herein or in the Special Conditions, or directed by the Engineer.

In order to provide effective and continuous control of water pollution it may be necessary for the Contractor to perform the Contract work in small or multiple units, on an out of phase schedule, and with modified construction procedures. The Contractor shall provide temporary water pollution control measures, including but not limited to,

dikes, basins, ditches, and applying straw and seed, which become necessary as a result of his operations. The Contractor shall coordinate water pollution control work with all other work done on the Contract.

Before starting any work on the project, the Contractor shall submit, for acceptance by the Engineer, a program to control water pollution effectively during construction of the project. Such program shall show the schedule for the erosion control work and for all water pollution control measures which the Contractor proposes to take in connection with construction of the project to minimize the effects of his operations upon adjacent streams and other bodies of water. The Contractor shall not perform any clearing and grubbing or earthwork on the project, other than that specifically authorized in writing by the Engineer, until such program has been accepted.

If the measures being taken by the Contractor are inadequate to control water pollution effectively, the Engineer may direct the Contractor to revise his operations and his water pollution control program. Such directions will be in writing and will specify the items of work for which the Contractor's water pollution control measures are inadequate. No further work shall be performed on said items until the water pollution control measures are adequate and, if also required, a revised water pollution control program has been accepted.

The Engineer will notify the Contractor of the acceptance or rejection of any submitted or revised water pollution control program in not more than five (5) days.

The Owner will not be liable to the Contractor for failure to accept all or any portion of an originally submitted or revised water pollution control program, nor for any delays to the work due to the Contractor's failure to submit an acceptable water pollution control program.

The Contractor may request the Engineer to waive the requirement for submission of a written program for control of water pollution when the nature of the Contractor's operation is such that erosion is not likely to occur. Waiver of this requirement will not relieve the Contractor from responsibility for compliance with the other conditions of this Section. Waiver of the requirement for a written program for control of water pollution will not preclude requiring submittal of a written program at a later time if the Engineer deems it necessary because of the effect of the Contractor's operations.

Where erosion which will cause water pollution is probable due to the nature of the material or the season of the year, the Contractor's operations shall be so scheduled that permanent erosion control features will be installed concurrently with or immediately following grading operations.

Nothing in the terms of the Contract nor in the conditions in this Section shall relieve the Contractor of the responsibility for compliance with Sections 5650 and 12015 of the Fish and Game Code, or other applicable statutes relating to prevention or abatement of water pollution.

The Contractor shall also conform to the following conditions:

- A. Where working areas encroach on live streams, barriers adequate to prevent the flow of muddy water into streams shall be constructed and maintained between working areas and streams, and during construction of such barriers, muddying of streams shall be held to a minimum.
- B. Removal of material from beneath a flowing stream shall not be commenced until adequate means, such as a bypass channel, are provided to carry the stream free from mud or silt around the removal operations.
- C. Should the Contractor's operations require transportation of materials across live streams, such operations shall be conducted without muddying the stream. Mechanized equipment shall not be operated in the stream channels of such live streams except as may be necessary to construct crossings or barriers and fills at channel changes.
- D. Water containing mud or silt from aggregate washing or other operations shall be treated by filtration, or retention in a settling pond, or ponds, adequate to prevent muddy water from entering live streams.

E. Oily or greasy substances originating from the Contractor's operations shall not be allowed to enter or be placed where they will later enter a live stream.

F. Portland cement or fresh portland cement concrete shall not be allowed to enter flowing water of streams.

G. When operations are completed, the flow of streams shall be returned as nearly as possible to a meandering thread without creating possible future bank erosion and settling, pond sites shall be graded so they will drain and will blend in with the surrounding terrain.

H. Material derived from roadway work shall not be deposited in a live stream channel where it could be washed away by high stream flows.

I. Where there is possible migration of anadromous fish in streams affected by construction on the project, the Contractor shall conduct his operations so as to allow free passage of such migratory fish.

Compliance with the requirements of this Section shall in no way relieve the Contractor from his responsibility to comply with the other conditions of the Contract, in particular his responsibility for damage and for preservation of property.

Full compensation for conforming to the requirements of this Section shall be considered as included in the prices paid for the various items of work and no additional compensation will be allowed therefor.

G7.06 SOUND CONTROL REQUIREMENTS. The Contractor shall comply with all local sound control and noise level rules, regulations and ordinances which apply to any work performed pursuant to the Contract.

Each internal combustion engine, used for any purpose on the job or related to the job, shall be equipped with a muffler of a type recommended by the manufacturer. No internal combustion engine shall be operated on the project without said muffler.

G7.07 USE OF PESTICIDES. The Contractor shall comply with all rules and regulations of the Department of Food and Agriculture, the Department of Health, the Department of Industrial Relations and all other agencies which govern the use of pesticides required in the performance of the work on the Contract.

Pesticides shall include but shall not be limited to herbicides, insecticides, fungicides, rodenticides, germicides, nematocides, bactericides, inhibitors, fumigants, defoliants, desiccants, soil sterilants, and repellents.

Any substance or mixture of substances intended for preventing, repelling, mitigating or destroying weeds, insects, diseases, rodents or nematodes and any substance or mixture of substances intended for use as a plant regulator, defoliant or desiccant shall be considered as pesticide.

G7.08 WEIGHT LIMITATIONS. Unless expressly permitted in the Technical Conditions, the Contractor shall not operate construction equipment or vehicles of any kind which, laden or unladen, exceed the maximum weight limits set forth in Division 15 of the Vehicle Code, over completed or existing base, surfacing, pavement or structures.

Contractor shall be responsible for any damage he may cause to bridges, culverts, and road structures. He shall determine in advance the allowable safe load for each structure and, if necessary, provide special shoring and support at his expense. Contractor shall seek approval from appropriate jurisdictions for use of designated routes for access to and from the project site.

G7.09 PAYMENT OF TAXES. The Contract prices paid for the work shall include full compensation for all taxes which the Contractor is required to pay, whether imposed by Federal, State or local government, including, without being limited to, Federal excise tax. No tax exemption certificate nor any document designed to exempt the Contractor from payment of any tax will be furnished to the Contractor by the Owner, as to any tax on labor,

services, materials, transportation, or any other items furnished pursuant to the Contract.

The Contractor shall withhold and pay any and all sales and use taxes, withholding taxes, whether State or Federal, Social Security taxes, State Unemployment Insurance charges and all other taxes which are now or hereafter may be required to be paid or withheld under any laws.

G7.10 PERMITS AND LICENSES. The Contractor shall procure all permits and licenses (except those procured or to be procured by the Owner which are listed in the Special Conditions or Specifications), pay all charges and fees, and give all notices necessary and incident to the due and lawful prosecution of the work.

The Environmental Quality Act (Public Resources Code, Section 21000 to 21176) may be applicable to permits, licenses and other authorizations which the Contractor must obtain from State or local agencies in connection with performing the work of the Contract. The Contractor shall comply with the provisions of that Act in obtaining such permits, licenses and other authorizations and they shall be obtained in sufficient time to prevent delays to the work.

The Contractor shall comply with permits obtained by the Owner for the work which are listed in the Special Conditions or Specifications.

G7.11 SUBSURFACE EXCAVATIONS, NOTIFICATION. Attention is directed to Government Code Section 4216 which provides, in part:

"Except in an emergency, every person planning to conduct any excavation shall contact the appropriate regional notification center at least two working days prior to commencing that excavation, if the excavation will be conducted in an area which is known, or reasonably should be known, to contain subsurface installations other than the underground facilities owned or operated by the excavator. The regional notification center shall provide an inquiry identification number to the person who contacts the center and shall notify any member, if known, who has a subsurface installation in the area of the proposed excavation."

The Contractor shall contact the regional notification center, "Underground Service Alert," and schedule the work to allow ample time for the center to notify its members and, if necessary, for any member to field locate and mark its facilities.

G7.12 PATENTS. The Contractor shall assume all costs arising from the use of patented materials, equipment, devices or processes, used on or incorporated in the work and shall indemnify and save harmless the Owner, the Engineer, and their duly authorized representatives from all suits at law, or actions of every nature for, or on account of, the use of patented materials, equipment, devices or processes. In case such materials, equipment, devices or processes are held to constitute an infringement and their use enjoined, the Contractor, at his expense, shall: (a) secure for the Owner the right to continue using said materials, equipment, devices or processes by suspension of the injunction or by procuring a license or licenses, or (b) replace such materials, equipment, devices or processes, or (c) modify them so that they become noninfringing or remove the enjoined materials, equipment, devices or processes and refund the sums paid therefor without prejudice to any other rights of the Owner or the Engineer.

The attention of the Contractor is directed to the following information:

- A. A portion of the pipe replacement work called for on this project will require the Contractor to use a trenchless method of construction.
- B. Some forms of trenchless pipe replacement construction are referred to as "pipe bursting" or "pipe cracking".
- C. The District has been notified by British Gas, 100 Thames Valley Park Drive, Reading, Berkshire, RG6 1PT, Great Britain, that it holds U.S. Patent No. 4738565, which British Gas contends covers pipe bursting or pipe cracking methodologies.
- D. The District is unable to determine whether any form of trenchless pipe replacement which may be

permitted by these project specifications would be covered by the British Gas patent or by any other patent or intellectual property right claim. However, pursuant to the conditions of this Section G7.12, it is the obligation of the Contractor to take whatever measures, including the acquisition of licenses or other rights of use, which are required with respect to any such patents or intellectual property right claims and to defend, indemnify and hold the District harmless from any such patents or claims without any cost or expense to the District.

G7.13 SAFETY REQUIREMENTS. The Contractor shall be solely responsible for initiating, maintaining, and supervising all safety precautions and programs in connection with the Work. Contractor shall submit documentation that designated individuals have received competent person training. The Contractor shall take all necessary precautions for the safety of, and shall provide the necessary protection to prevent damage, injury or loss to:

- A. All persons at the site and other persons and organizations who may be affected thereby;
- B. All the Work and materials and equipment to be incorporated therein, whether in storage on or off the site; and
- C. Other property at the site or adjacent thereto, including trees, shrubs, lawns, walks, pavements, roadways, structures, and utilities not designated for removal, relocation, or replacement in the course of construction.

(a) Safety Measures: The Contractor shall promptly and fully comply with and carry out and shall, without separate charge to the Owner, enforce compliance with safety and health requirements stated herein, prescribed by all applicable Laws and Regulations (whether referred to herein or not) of any public body having jurisdiction or charged with the enforcement thereof, for the safety of persons or property or to protect them from damage, injury, or loss and shall erect and maintain all necessary safeguards for such safety and protection. Where any of these safety regulations are in conflict, the more stringent requirement shall be followed.

The Contractor shall notify Engineer of adjacent property and utilities when performance of the Work may affect them, and shall cooperate with them in the protection, removal, relocation, and replacement of their property. The Contractor shall take such other measures as may be necessary to ensure that work is done in a safe manner and that the safety and health of the employees and people of the local communities is safeguarded.

Compliance with these by subcontractors shall be the sole responsibility of the Contractor.

(b) Personal Hygiene: Persons involved in the work may be exposed to wastewater microorganisms that could cause infections and diseases. The Contractor shall require his personnel to observe proper hygiene such as washing of hands and other exposed portions of the body with disinfecting soap and water before eating, smoking, applying lip balm, etc.

(c) Public Safety and Convenience: The Contractor shall conduct the work so as to ensure the least possible obstruction to traffic and inconvenience to the general public in the vicinity of the work and to ensure the protection of persons and property. No road or street shall be closed to the public except with the permission of the Owner and the proper governmental authorities. Fire hydrants on or adjacent to the work shall be accessible to fire-fighting equipment. Temporary provisions shall be made by the Contractor to insure the use of sidewalks, private and public driveways and proper functioning of gutters, sewer inlets, drainage ditches and culverts, irrigation ditches and natural water courses.

(d) Flammable, Hazardous and/or Toxic Materials: Solvents, gasoline, and other hazardous materials may be in the wastewater, and therefore, the work site may be hazardous to open flames, sparks, or unventilated occupancy. The Contractor shall take measures to ensure his personnel observe proper safety precautions when working in these areas. Any flammable, hazardous or

toxic materials brought into the work area must be pre-approved, in writing, by the Owner and must be accompanied by the most current MSD sheet. Any flammable, hazardous or toxic materials brought into the work area must be properly stored to prevent spontaneous combustion or dispersion, and must be stored using the appropriate level of secondary spill containment. Flammable, hazardous or toxic materials may never be placed into any sewer or drain piping nor buried on the Owner's property. The Contractor shall maintain a current and up-to-date copy of all laws, ordinances, codes, rules, regulations and lawful orders of any regulatory authority having jurisdiction or control over flammable, hazardous or toxic materials and, at Contractor's expense, shall comply with said laws, ordinances, codes, rules, regulations and lawful orders.

The Contractor must provide all certificates and registrations as required by the California Business and Professions Code, CCR Title 22, and other regulations governing the removal or remediation of hazardous substances.

(e) Excavation and Trenching. The Contractor shall promptly, and before the following conditions are disturbed, notify the Owner, in writing, of any:

- (1) Material that the Contractor believes may be material that is hazardous waste, as defined in Section 25117 of the Health and Safety Code, that is required to be removed to a Class I, Class II, or Class III disposal site in accordance with provisions of existing law.
- (2) Subsurface or latent physical conditions at the site differing from those indicated.
- (3) Unknown physical conditions at the site of any unusual nature, different materially from those ordinarily encountered and generally recognized as inherent in work of the character provided for in the contract.

The Owner shall promptly investigate the conditions, and if it finds that the conditions do materially so differ, or do involve hazardous waste, and cause a decrease or increase in the Contractor's cost of, or the time required for, performance of any part of the work shall issue a change order under the procedures described in the contract.

In the event that a dispute arises between the Owner and the Contractor whether the conditions materially differ, or involve hazardous waste, or cause a decrease or increase in the Contractor's cost of, or time required for, performance of any part of the work, the Contractor shall not be excused from any scheduled completion date provided for by the contract, but shall proceed with all work to be performed under the contract. The Contractor shall retain any and all rights provided either by contract or by law, which pertain to the resolution of disputes and protests between the contracting parties.

EMERGENCY WORK:

A. Corrective Action: The Contractor shall perform any and all operations and shall furnish any materials and equipment necessary during an emergency endangering life or property. In all cases, Contractor shall notify the Engineer of the emergency as soon as practicable, but shall not wait for instruction before proceeding to properly protect both life and property.

Adjustments to the contract: If as a result of an emergency, work is added to or deleted from the contract between the Owner and the Contractor, the contract shall be adjusted in terms of compensation, time for performance and/or other relevant contract conditions in accordance with the provisions of the contract governing such matters.

B. Emergency Contacts: The Contractor shall file with the Owner a written list giving the names, addresses, and telephone numbers of at least two of his representatives who can be contacted at any time in case of emergencies. The representative shall be fully authorized and equipped to correct unsafe or

inconvenient conditions on short notice. The Contractor shall promptly notify the Owner of all changes in the listing.

C. Special Corrective Actions: The Owner reserves the right, exercisable without advance notice to the Contractor, to take corrective action and to perform necessary repairs in an emergency if the Owner determines for any reason that the Contractor is or may be unable to respond to the emergency in as timely or effective a manner as the Owner could do so. Emergency work undertaken by the Owner under these circumstances may be performed by the Owner's own forces and resources, by contract with others, or both. The exercise of this right shall not terminate the contract between the Contractor and the Owner.

D. Stop Orders: In the event the Contractor fails to observe any of the necessary safety provisions, the Owner may stop the work and direct the Contractor to comply with the applicable provisions, or may order the necessary work be done by others. All impacts, both monetary and time-related, associated with stoppage of the work in order to comply with the contract specifications pertaining to safety requirements, and all costs of having the necessary work done by others shall be borne by and be the obligation of the Contractor.

G7.14 TRENCH EXCAVATION SAFETY PLAN. Attention is directed to California Labor Code Section 6705. At least five days in advance of excavation of any trench five feet or more in depth, the Contractor shall submit to the Engineer a detailed plan showing the design of shoring, bracing, sloping and other provisions to be made for worker protection from the hazard of caving ground during the excavation of such trench or trenches. If such plan varies from the shoring system standards established by the State Construction Safety Orders, the plan shall be prepared and signed by a registered civil or structural engineer. Nothing in this Section shall be deemed to allow the use of a shoring, sloping or protective system less effective than that required by the Construction Safety Orders of the Division of Industrial Safety. Nothing in this Section shall be construed to impose liability on the Owner, the Engineer or any of their employees.

G7.15 SANITARY PROVISIONS. The Contractor shall conform to the rules and regulations pertaining to sanitary provisions established by the State, and to County, City and municipal laws and ordinances as may be applicable. Toilets for use of employees on the work shall be furnished where needed and shall be maintained by the Contractor. Their use shall be strictly enforced. Owner sanitary facilities will not be available for use by the Contractor's employees, except where specifically designated in writing by the Engineer.

G7.16 PUBLIC CONVENIENCE. The Contractor shall so conduct his operations as to offer the least possible obstruction and inconvenience to the public and he shall have under construction no greater length or amount of work than he can prosecute properly with due regard to the rights of the public.

All public traffic shall be permitted to pass through the work with as little inconvenience and delay as possible. The Contractor shall obtain approval of his plans for the routing and control of traffic from the appropriate city, county or State agency. Where the temporary rerouting or closing to traffic of any public street or highway is necessary, the Contractor shall make all necessary arrangements with the appropriate city, county or State agency.

All trucks coming to the site or leaving the site with materials or loose debris shall be loaded in a manner which will prevent dropping of material or debris on public streets. Spillage resulting from hauling operations along or across any public traveled way shall be removed immediately at the Contractor's expense.

Construction operations shall be conducted in such a manner as to cause as little inconvenience as possible to owners of abutting property. Convenient access to driveways, houses and buildings along the line of work shall be maintained, and temporary approaches to roads or highways shall be provided and kept in good condition. Roadway excavations shall be conducted in such a manner as to provide a reasonably smooth and even surface satisfactory for use by public traffic at all times.

For work in public right-of-way, the Contractor shall comply with the rules and regulations of the State, County or local agency that owns the right-of-way.

All costs of complying with public convenience requirements of the Owner or other agencies shall be included in the

Contract price.

The Engineer shall have the authority, but not the duty, to stop the Contractor from beginning new work until the conditions of this Section have been met and/or to assess liquidated damages.

G7.17 PUBLIC SAFETY. The Contractor shall assume all responsibility for public safety during construction, and all costs arising therefrom shall be included in the Contract amount. Whenever the Contractor's operations create a condition hazardous to traffic or to the public, he shall furnish, erect and maintain, at his expense, such fences, barricades, lights, signs and other devices and take such other protective measures as are necessary to prevent accidents or damage or injury to the public. The Contractor shall also furnish such flagmen as are necessary to give adequate warning to traffic or to the public of any dangerous conditions. For work in public right-of-way, the Contractor shall comply with the rules and regulations of the State, County or local agency that owns the right-of-way.

G7.18 PRESERVATION OF PROPERTY. Due care shall be exercised to avoid injury to existing improvements or facilities, utility facilities, adjacent property and trees, shrubs and other plants that are not to be removed.

Trees, shrubs and other plants that are not to be removed, and pole lines, fences, signs, survey markers and monuments, buildings and structures, conduits, pipe lines, sewer and waterlines, highway facilities, and any other improvements or facilities, under or above ground, that are within or adjacent to the work limit line shall be protected from injury or damage, and the Contractor shall provide and install suitable safeguards to protect such objects from injury or damage. If such objects are injured or damaged by reason of the Contractor's operations, they shall be replaced or restored at the Contractor's expense. The facilities shall be replaced or restored to a condition as good as when the Contractor entered upon the work, or as good as required by the Specifications if any such objects are a part of the work being performed under the Contract. The Engineer may make or cause to be made such temporary repairs as are necessary to restore to service any damaged facility. The cost of such repairs shall be borne by the Contractor and may be deducted from any monies due or to become due to the Contractor under the Contract.

The fact that any underground facility is not shown on the Contract Plans shall not relieve the Contractor of his responsibility under Section G8.15, "Existing Utilities," of the General Conditions. It shall be the Contractor's responsibility, pursuant thereto, to ascertain the location of such underground improvements or facilities which may be subject to damage by reason of his operations.

Full compensation for furnishing all labor, materials, tools, equipment and incidentals, and for doing all the work involved in protecting or repairing property as specified in this Section, shall be considered as included in the prices paid for the various Contract items of work and no additional compensation will be allowed therefor.

G7.19 RESPONSIBILITY FOR DAMAGE. The Owner and all Members of the Owner's governing body, officers, employees and authorized agents thereof connected with the work, the Engineer shall not be answerable or accountable in any manner: for any loss or damage that may happen to the work or any part thereof; for any loss or damage to any of the materials or other things used or employed in performing the work; for injury to or death of any person (including but not limited to workers or the public) from any cause whatsoever; or damage to property from any cause whatsoever.

The Contractor shall be responsible for any liability imposed by law and for any injuries to or death of any person (including but not limited to workers and the public) and for damage to property resulting from defects or from obstructions or from any cause whatsoever during the progress of the work or at any time before its completion and final acceptance.

To the maximum extent permitted by law, the Contractor shall indemnify and save harmless the Owner and all members of the governing body, officers, employees and authorized agents thereof, the Engineer from all claims, suits or actions of every name, kind and description, brought for, or on account of, injuries to or death of any person (including but not limited to employees of Contractor, of subcontractors, or of any other person, firm or entity and the public) or damage to property arising from any cause whatsoever during the progress of the work or at any time before its final completion and acceptance. The duty of the Contractor to indemnify and save harmless includes the

duties to defend (by legal counsel satisfactory to the indemnities) as set forth in Section 2778 of the Civil Code and to pay attorney's fees and litigation costs required by such defense.

With respect to third party claims against Contractor, the Contractor waives any and all rights to any type of express or implied indemnity against the Owner, members of its governing body, officers, employees or authorized agents, and the Engineer. It is the intent of the parties that the Contractor shall indemnify and hold harmless the Owner, members of its governing body, officers, employees and authorized agents, the Engineer from any and all claims, suits, or actions arising from any cause whatsoever as set forth above regardless of the existence or degree of fault or negligence on the part of the Owner, the Engineer, the Contractor, a subcontractor or employee of any of these, other than the active negligence of the Owner or its Directors, officers, employees or authorized agents, and the Engineer.

G7.20 RESPONSIBILITY FOR WORK AND MATERIALS. Until the acceptance of the Contract, the Contractor shall have the charge and care of the work and of the materials to be used therein, including materials for which he has received partial payment, and shall bear the risk of injury, loss or damage to any part thereof by the action of the elements or from any other cause, whether arising from the execution or from the nonexecution of the work. The Owner will not grant relief from maintenance and responsibility for a portion of the total work. The Contractor shall rebuild, repair or restore all injuries, losses or damages to any portion of the work and materials occasioned by any cause before its completion and acceptance and shall bear the expense thereof. Where necessary, the Contractor shall, at his expense, provide suitable drainage and erect such temporary structures as are necessary to protect the work and materials from damage. The suspension of the work from any causes whatever shall not relieve the Contractor of his responsibility for the work and materials as herein specified. The Contractor shall properly store materials which have been partially paid for by the Owner. Such storage by the Contractor shall be on behalf of the Owner and the Owner shall at all times be entitled to the possession of such materials, and the Contractor shall promptly return the same to the site of the work when requested. The Contractor shall not dispose of any of the materials so stored except on written authorization from the Engineer.

G7.21 GENERAL LIABILITY OF CONTRACTOR. Contractor hereby agrees to indemnify and save harmless Owner and the Engineer and their respective Boards, officers, agents and employees of and from any and all claims, suits or actions of every name, kind and description which may be brought against their respective Boards, officers, agents or employees by reason of any injury to or death of any person or property damage suffered or sustained by any person or corporation caused by, or alleged to have been caused by, any act or omission, negligent or otherwise, of Contractor, his officers, agents or employees in the performance of any work required of the Contractor by this Agreement. The Owner shall not be deemed to have waived rights it may have against Contractor because of the acceptance by Owner of any of the insurance policies described in this Agreement.

The duty of Contractor to indemnify and save harmless, as set forth herein, shall include a duty to defend as set forth in Section 2778 of the California Civil Code; provided, however, that nothing herein shall be construed to require Contractor to indemnify Owner and the Engineer and their respective Boards, officers, agents and employees against any responsibility or liability in contravention of Section 2782 of the California Civil Code.

G7.22 PREVAILING WAGE INDEMNITY AND WAIVER

A. Contractor shall, and hereby agrees to, unconditionally indemnify, reimburse, defend, protect and hold harmless Owner and its elective and appointive boards, commissions, officers, agents, attorneys, consultants and employees, and all of their respective successors and assigns, from and against any and all claims, demands, suits and actions at law or in equity, and losses, liabilities, expenses, penalties, fines, orders, judgments, injunctive or other relief, and costs and damages of every kind, nature and description (including but not limited to attorneys' fees and court costs, with counsel reasonably acceptable to Owner), and administrative, enforcement or judicial proceedings, whether known or unknown, and which directly or indirectly, in whole or in part, are caused by, arise from, or relate to, or are alleged to be caused by, arise from, or relate to, the payment or requirement of payment of prevailing wages, or any act or omission of Owner related to this Agreement with respect to the payment or requirement of payment of prevailing wages, whether or not any insurance policies shall have been determined to be applicable to any such claims, demands, suits, actions, losses, liabilities, expenses, penalties, fines, orders, judgments, injunctive or other relief, costs, damages, or administrative, enforcement or judicial proceedings. It is further agreed that Owner does not, and shall not, waive any rights against Contractor which it may have by reason of this indemnity and hold harmless agreement because of the acceptance by Owner, of any of the insurance policies described herein.

B. The Contractor acknowledges that it has been informed of the requirement to pay, at a minimum, prevailing wages in this project. As a result, the Contractor hereby waives any and all claims it might otherwise have against the public agency pursuant to Labor Code Sections 1726 and 1781.

G7.23 PUBLIC LIABILITY INSURANCE. The Contractor shall procure and maintain Broad Form Comprehensive General Liability or Commercial General Liability Insurance, and Code 1 or "Any Auto" Business Automobile Liability Insurance policies in amounts for each policy of not less than:

A. General Liability: One Million Dollars (\$1,000,000.00) per occurrence for bodily injury, personal injury and property damage, and subject to that limitation for the injury to or death of one person of not less than Two Million Dollars (\$2,000,000.00) for injury to or death of two or more persons as a result of any one accident or occurrence, with personal or bodily injury aggregate in an amount not less than Two Million Dollars (\$2,000,000.00). If Commercial General Liability Insurance or other form with a general aggregate limit is used, either the general aggregate limit shall apply separately to this project or the general aggregate limit shall be three times the required occurrence limit.

B. Automobile Liability: One Million Dollar (\$1,000,000.00) per accident for bodily injury, personal injury and property damage, and subject to that limitation for the injury to or death of one person, not less than Two Million Dollars (\$2,000,000.00) for injury to or death of two or more persons as a result of any one accident or occurrence, with personal or bodily injury aggregate in an amount not less than Two Million Dollars (\$2,000,000.00).

Policies shall provide coverage for property damages, personal injuries, bodily injuries or death suffered or alleged to have been suffered by any person or persons by reason of or in the course of operations under the contract, whether occurring by reason of acts or omissions of the Contractor or any subcontractor or both. Coverage shall be at least as broad as Insurance Services Office Commercial General Liability coverage (occurrence form CG 0001) for general liability insurance and Insurance Services Office form number CA 0001 (Ed. 1/87) for automobile liability insurance. Such insurance shall be maintained until final acceptance of the work by the Owner and shall continue of a period of 365 days after acceptance of the work by the Owner. The general liability insurance policy required by this Section shall include explosion, collapse, underground excavation or removal of lateral support.

The general liability insurance policies shall also cover the Owner, its Board, officers, agents, employees, and servants of the Contractor, the Contractor's subcontractors, City of El Cerrito, the City of Richmond, County of Contra Costa, and the District's Engineer as insureds.

The general liability insurance policies required under this Section, shall contain, or be endorsed to contain, the following other conditions:

A. The Contractor's insurance coverage shall be primary insurance. Any insurance or self-insurance maintained by the Owner, its Board, officers, agents, employees and servants of the Contractor, the Contractor's subcontractor's, City of El Cerrito, the City of Richmond, County of Contra Costa, and the District's Engineer shall be excess of Contractor's insurance and shall not contribute with it.

B. The Contractor's insurance coverage shall apply separately to each insured against whom a claim is made or suit is brought, except with respect to the limits of the insurer's liability.

C. The Owner, its Board, officers, agents, employees and servants, the Contractor, the Contractor's subcontractors, City of El Cerrito, the City of Richmond, County of Contra Costa, and the District's Engineer are to be covered as insureds with respect to liability arising out of automobiles owned, leased, hired or borrowed by or on behalf of the Contractor; and with respect to liability arising out of work or operations performed by or on behalf of the Contractor including materials, parts or equipment furnished in connection with such work or operations.

D. Any failure to comply with reporting provisions of the policies shall not affect coverage provided to the Owner, its Board, officers, agents, employees, and servants of the Contractor, the Contractor's

subcontractors, City of El Cerrito, the City of Richmond, County of Contra Costa, and the District's Engineer.

E. The Contractor's liability insurance coverage shall not be suspended, voided, canceled, reduced in coverage or in limits except after forty-five (45) days' prior written notice by certified mail, return receipt requested, has been given to the Owner.

The contractor shall require all subcontractors, whether primary or secondary, if any, to take out and maintain General Liability and Business Automobile Liability in the amounts set out in this Section.

At least ten (10) days prior to commencing work there under, Contractor shall furnish the Owner certificates of each policy of insurance required here under, in form and substance satisfactory to Owner. Such certificates shall show the type, amount, class of operations covered, effective dates and date of expiration of policies.

G7.24 WORKER'S COMPENSATION INSURANCE. The Contractor and all subcontractors shall cover or insure under the applicable laws relating to worker's compensation or employer's liability insurance, all of their employees working on or about the construction site, regardless of whether such coverage or insurance is mandatory or merely elective under the law, and the Contractor shall defend, protect and save harmless the Owner from and against all claims, suits and actions arising from any failure of the Contractor or any such subcontractor to maintain such insurance. The Contractor shall maintain Employer's Liability Insurance with minimum limits of One Million Dollars (\$1,000,000.00) per accident for bodily injury or disease.

G7.25 PROPERTY INSURANCE. Unless otherwise provided in the Special Conditions, the Contractor will purchase and maintain, in a company or companies lawfully authorized to do business in California, and acceptable to the Owner, property insurance upon the entire work, in the amount of fifty percent (50%) the Contract price. Such property insurance shall be maintained until final payment has been made.

Property insurance shall be on an all-risk policy form (commonly known as "Builder's Risk-All Risk") and shall insure against the perils of earthquake, landslide, flood, collapse, loss due to the result of faulty workmanship or design, and all other risks and shall cover reasonable compensation for Engineer's services and expenses required as a result of such insured loss. This insurance shall insure the interests of the Owner, the Contractor, and subcontractors in the work. Contractor and Owner will be named as additional insureds on the policy.

The property insurance may contain deductibles not to exceed the amounts specified in the Special Conditions. If no amounts are specified, the insurance shall be written without deductibles. The Contractor shall pay costs not covered because of such deductibles.

Complete copies of each policy of insurance and certificates of each policy, in form and substance satisfactory to Owner, shall be filed with Owner prior to the commencement of work. The policies and certificates shall provide:

- A. That Owner is included as a named insured;
- B. That losses shall be payable to Contractor and Owner as their interests appear; and
- C. The policy will not be canceled, nor coverage materially altered, without thirty (30) days, prior written notice to Owner.

G7.26 DEDUCTIBLES AND SELF-INSURED RETENTIONS. Any deductibles or self-insured retentions must be declared to and approved by the District. At the option of the District, either: the insurer shall reduce or eliminate such deductibles or self-insured retention's as respects the District, its Board, officers, agents, employees and servants, the City of El Cerrito, the City of Richmond, County of Contra Costa, and the District's Engineer, or the Contractor shall provide a financial guarantee satisfactory to the District guaranteeing payment of losses and related investigations, claim administration and defense expenses.

G7.27 EVIDENCES AND CANCELLATION OF INSURANCE AND INSURER QUALIFICATIONS. Prior to execution of the contract, the Contractor shall file with the District evidences of insurance from the insurer

certifying to the coverage of all insurance required herein. All evidences of insurance shall be certified by a properly authorized officer, agents, general agent or qualified representative of the insurer and shall certify the names of the insured, the type and amount of the insurance, the location and operations to which the insurance applies, the expiration date, and that the insurer will give, by registered mail, notice to the District at least forty-five (45) days prior to the effective date of any cancellation, lapse or material change in the policy.

The Contractor shall deliver to the Owner all such policy or policies of insurance, endorsements and the receipt for payment of premiums thereon; and should the Contractor neglect to obtain and maintain in force any such insurance or deliver such policy or policies, endorsements and receipts to the Owner, then it shall be lawful for the Owner to obtain and maintain such insurance, and the Contractor hereby appoints the Owner his true and lawful attorney to do all things necessary for this purpose. All money expended by the Owner for insurance premiums under the conditions of this Section shall be charged to the Contractor. The Contractor shall use the Owner approved endorsement forms provided in the proposal section of these specifications to comply with this Section.

All insurance required by this contract shall be placed with insurers qualified by the State of California to do business in California as insurers, and all of the insurers shall have a current A.M. Best's Rating of no less than A: VII.

Notwithstanding the language of the preceding paragraph, Owner may disqualify an insurer proposed to provide insurance coverage required by these contract specifications if the Owner has cause to believe the insurer is likely to be incapable of providing that insurance coverage.

G7.28 DISPOSAL OF MATERIAL OUTSIDE THE WORK SITE. Unless otherwise specified in the Specifications, the Contractor shall make his own arrangements for disposing of materials outside the work site and he shall pay all costs involved.

When any material is to be disposed of outside the work site, the Contractor shall first obtain a written permit from the property owner on whose property the disposal is to be made and he shall file with the Engineer said permit or a certified copy thereof, together with a written release from the property owner absolving the Owner from any and all responsibility in connection with the disposal of material on said property, and before any material is disposed of on said property, the Contractor shall obtain written permission from the Engineer to dispose of the material at the location designated in said permit.

When material is disposed of as above provided and the disposal location is visible from a highway, the Contractor shall dispose of the material in a neat and uniform manner to the satisfaction of the Engineer.

G7.29 COOPERATION. Should construction be under way by other forces or by other contractors within or adjacent to the limits of the work specified, or should work of any other nature be under way by other forces within or adjacent to said limits, the Contractor shall cooperate with all such other contractors or other forces to the end that any delay or hindrance to their work will be avoided. The right is reserved to perform other or additional work at or near the site at any time, by the use of other forces.

When two or more contractors are employed on related or adjacent Owner work, each shall conduct his operations in such a manner as not to cause any unnecessary delay or hindrance to the other. Each contractor shall be responsible to the other for all damage to work, to persons or property caused to the other by his operations, and for loss caused the other due to his unnecessary delays or failure to finish the work within the time specified for completion.

G7.30 OCCUPANCY PRIOR TO ACCEPTANCE. The Owner reserves the right to occupy all or any part of the project prior to completion of the entire Contract, upon written order therefor. In such event, the Contractor will be relieved of responsibility for any injury or damage to such part as results from such occupancy and use by the Owner.

If the Contractor carries insurance against damage to such premises or against liability to third persons covering the premises so used and occupied by the Owner, and if such occupancy results in increased premiums for such insurance, the Owner will pay to the Contractor the added cost for such insurance during the period of occupancy. Such occupancy does not constitute acceptance by the Owner either of the complete work or of any portion thereof,

nor will it relieve the Contractor of full responsibility for correcting defective work or materials found at any time before the formal written acceptance of the entire Contract by the Owner or during the full guarantee period after such acceptance.

G7.31 ACCEPTANCE OF THE WORK. When the Engineer has made the final inspection as provided in Section G5.14 and determines that the work has been completed in all respects in accordance with the Contract Documents, he will recommend that the Owner formally accept the work. Immediately upon and after such formal written acceptance by the Owner, the Contractor will be relieved of the duty of maintaining the work as a whole, and he will not be required to perform any further work thereon except as provided in Sections G4.13, "GUARANTY OF WORK" and G4.14, "CORRECTION OF WORK DURING WARRANTY PERIOD."

G7.32 PROPERTY RIGHTS IN MATERIALS. Nothing in the Contract shall be construed as vesting in the Contractor any right of property in the materials used after they have been attached or affixed to the work or soil or after partial payment has been made for material delivered on the ground or stored subject to or under the control of the Owner and unused. All such material shall become the property of the Owner upon being so attached or affixed or upon payment for materials delivered on the ground or stored subject to or under the control of the Owner and unused, as provided in Section 9.

G7.33 RIGHTS IN LAND AND IMPROVEMENTS. The Contractor shall make no arrangements with any person to permit occupancy or use of any land, structure or building within the limits of the work, for any purpose whatsoever, either with or without compensation, in conflict with any agreement between the Owner and any owner, former owner or tenant of such land, structure or buildings. The Contractor shall not occupy Owner-owned property outside the limit of the work as shown on the Contract Drawings unless he obtains prior approval.

G7.34 ANTITRUST CLAIMS. The Contractor's attention is directed to the following provision of Government Code Section 4551 which shall be applicable to the Contractor and his subcontractors:

"In entering into a public works contract or a subcontract to supply goods, services or materials pursuant to a public works contract, the Contractor or subcontractor offers and agrees to assign to the awarding body all right, title and interest in and to all causes of action it may have under Section 4 of the Clayton Act (15 U.S.C. Sec. 15) or under the Cartwright Act (Chapter 2 [commencing with Section 16700] of Part 2 of Division 7 of the Business and Professions Code), arising from purchases of goods, services or materials pursuant to the public works contract or the subcontract. This assignment shall be made and become effective at the time the awarding body tenders final payment to the Contractor, without further acknowledgment by the parties."

G7.35 ACCESS TO THE WORK. The Contractor shall satisfy himself that the jurisdictions through which his operations and haul routes pass will permit such operations with respect to type of vehicle, laden weights, frequency and dimensions of loads, hours of operation and required traffic control. All necessary permits, licenses or bonds shall be obtained and paid for by the Contractor.

G7.36 PERSONAL LIABILITY. Neither the Owner's governing body, its Officers, Agents, Representatives nor Employees nor Engineer shall be personally responsible for any liability arising under or by virtue of this Contract.

G7.37 THIRD PARTY RIGHTS. Nothing in the Contract is intended to create the public or any member thereof a third party beneficiary here under.

G7.38 INDEPENDENT CONTRACTOR STATUS. The Contractor shall independently perform all work under this Contract and shall not be considered as an agent or employee of the Owner, nor shall the Contractor's subcontractors or employees be considered as subagents of the Owner.

SECTION 8

PROSECUTION AND PROGRESS

G8.01 SUBCONTRACTING. The Contractor shall give his personal attention to the fulfillment of the Contract and shall keep the work under his control.

No subcontractor will be recognized as such and nothing in the Contract Documents shall create any contractual relationship between the Owner and any subcontractor. The Contractor is as fully responsible to the Owner for the acts and omissions of his subcontractors and of persons either directly or indirectly employed by them as he is for the acts and omissions of persons directly employed by him.

Attention is directed to the requirements of Sections 4100 to 4113, inclusive, of the California Public Contract Code which are applicable to this Contract. Each bidder shall list in his Bid the name and business address of each subcontractor to whom the bidder proposes to subcontract a portion of the work, and shall list each subcontractor, licensed by the State of California, proposed by the bidder to specially fabricate and install a portion of the work. Said list shall include a description of the portion of the work which shall be done by each subcontractor. The bidder shall execute and submit with his Bid the "List of Subcontractors" on the form included in this book. Additional forms may be obtained from the Engineer. The Contractor shall not, without the consent of the Owner, either substitute any person as subcontractor in place of the subcontractor designated in the original List of Subcontractors, or sublet or subcontract any portion of the work in excess of one-half of one percent of the total amount of his proposal for which he did not originally designate a subcontractor.

When a portion of the work which has been subcontracted by the Contractor is not being prosecuted in a manner satisfactory to the Owner, the subcontractor shall be removed immediately on the request of the Owner, and shall not again be employed on the work.

The on-site production of materials produced by other than the Contractor's forces shall be considered as subcontracted. The erection, establishment or reopening of on-site plants for production of materials and the operation thereof in the production of materials for use on the work, shall conform to the requirements relating to labor set forth in the Contract Documents.

The Contractor shall require, by written agreement, each subcontractor to be bound to the Contractor by terms of the Contract Documents and to assume toward the Contractor all the obligations and responsibilities which the Contractor, by the Contract Documents, assumes toward the Owner, to the extent of the work to be performed by the subcontractor. Each subcontract agreement shall preserve and protect the rights of the Owner under the Contract Documents with respect to the work to be performed by the subcontractor, so that subcontracting will not prejudice such rights.

G8.02 ASSIGNMENT. The Owner and the Contractor, respectively, bind themselves, their partners, successors, assigns, and legal representatives to the other party hereto and to the partners, successors, assigns, and legal representatives of such other party with respect to all covenants, agreements, and obligation contained in the Contract Documents. The performance of the Contract may not be assigned except upon the written consent of the Owner. Consent will not be given to any proposed assignment which would relieve the original Contractor or his surety of their responsibilities under the Contract nor will the Owner consent to any assignment of a part of the work under the Contract.

The Contractor may assign monies due or to become due him under the Contract and such assignment will be recognized by the Owner, if given proper notice thereof, to the extent permitted by law, but any assignment of monies shall be subject to all proper set-off in favor of the Owner and to all deductions provided for in the Contract, and particularly all money withheld, whether assigned or not, shall be subject to being used by the Owner for the completion of the work in the event that the Contractor should be in default therein.

G8.03 NOTICE TO PROCEED. As soon as practicable after execution of the Contract by the Owner, approval by the Owner of Contract Bonds and all other documents listed in the Contract, and after receipt of acceptable

insurance certificates by the Owner, a written Notice to Proceed will be mailed to the Contractor. The effective date of the Notice to Proceed will be the date stated as such in the Notice to Proceed, provided that the effective date will not be earlier than the day following the issuance of the Notice to Proceed.

G8.04 BEGINNING OF WORK. The Contractor is not authorized to perform any work until he has received a Notice to Proceed from the Owner. Within ten (10) days after the effective date of such Notice to Proceed, the Contractor shall commence work and shall diligently prosecute the same to completion within the time limit provided in the Special Conditions.

The Contractor shall notify the Engineer, in writing, of his intent to begin work at least seventy-two (72) hours before work is begun and shall specify the date the Contractor intends to start. If the project has more than one location of work, a separate notice shall be given for each location.

Should the Contractor begin work in advance of receiving the Notice to Proceed and providing notice to the Engineer, any work performed by him in advance of such notice shall be considered as having been done by him at his own risk and as a volunteer.

G8.05 SCHEDULES AND PROGRESS REPORTS. The Contractor shall, within ten (10) days after the effective date of the Notice to Proceed, submit to the Engineer three copies of a construction schedule covering his operations for the work. The construction schedule shall be in the form of a bar chart or arrow diagram, unless a critical path method analysis is required by the Special Conditions or Specifications. The schedule shall show the order in which the Contractor proposes to carry out the work and the dates on which he expects to start and finish each part or division of the work (including procurement of materials, plant and equipment). The construction schedule shall be consistent with the time and order of work requirements of the Contract Documents and shall provide for expeditious and practicable execution of the work. If the Contractor desires to revise his construction schedule, or if it becomes necessary to revise it due to major changes, he shall submit three copies of the revised schedule for review and comment by the Engineer.

The Contractor shall, within ten (10) days after the effective date of the Notice to Proceed, also submit to the Engineer three copies of a schedule of submittals which is coordinated with the Contractor's construction schedule and with the review time provided in the Contract Documents.

The Contractor shall submit to the Engineer, at the time of submittal of the invoice for work completed (See Section G9.08), a schedule summary report in a form and of sufficient detail and character as approved by the Engineer. The schedule summary report shall include the updated current construction schedule and shall specify whether the project is on schedule and, if not, the reasons therefor. The monthly schedule summary report shall also indicate the delivery status of major and critical items of purchased equipment and material, the status of shop drawings and field fabricated work.

G8.06 SITE MEETINGS. The Contractor shall schedule meetings with the Engineer and each active subcontractor at the work site weekly, or at such other frequency as is acceptable to Engineer. Each subcontractor shall have presented a competent representative to report the conditions of his work and to discuss problems.

G8.07 TIME OF COMPLETION. The Contractor shall complete all or any designated portion of the work called for under the Contract in all parts and requirements within the time set forth in the Special Conditions.

G8.08 ADDITIONAL SHIFT WORK. The time limits specified for the completion of the work contemplated may be insufficient to permit completion of the work by the Contractor working a normal number of hours per day or week on a single shift basis. Where additional shifts or premium time pay are necessary to ensure that the work will be completed within the time limits specified, any resulting additional costs will be considered to be included in the price paid for the various Contract items of work and no additional compensation will be allowed therefor.

If the Contractor desires to carry on work at night or outside regular working hours, he shall give timely notice to the Engineer to allow satisfactory arrangements to be made for observing the work in progress.

G8.09 UNUSUAL MATERIALS IN EXCAVATIONS. While digging trenches or excavating, the Contractor

pursuant to Public Contract Code Section 7104 shall promptly, and before the following conditions are disturbed, notify the District and the Engineer, in writing, of any:

- A. Material that the Contractor believes may be material that is hazardous waste, as defined in Section 25117 of the Health and Safety Code, that is required to be removed to a Class I, Class II or Class III disposal site in accordance with provisions of existing law.
- B. Subsurface or latent physical conditions at the site differing from those indicated.
- C. Unknown physical conditions at the site, of any unusual nature, different materially from those ordinarily encountered and generally recognized as inherent in work of the character provided for in the contract.

The Owner shall promptly investigate the conditions, and if he finds that the conditions do materially so differ, or do involve hazardous waste, or cause a decrease or increase in the Contractor's cost of, or the time required for, performance of any part of the work shall issue a change order under the procedures described in Section G4.03.

In the event that a dispute arises between the Owner and the Contractor whether the conditions materially differ, or involve hazardous waste, or cause a decrease or increase in the Contractor's cost of, or time required for, performance of any part of the work, the Contractor shall not be excused from any scheduled completion date provided for by the contract, but shall proceed with all work to be performed under the contract. The Contractor shall retain any and all rights provided either by contract or by law which pertain to the resolution of disputes and protests between the contracting parties as described in Section G4.08.

G8.10 OWNER'S RIGHT TO STOP THE WORK. If the Contractor fails to promptly correct work which is not in accordance with the requirements of the Contract Documents or persistently fails to carry out work in accordance with the Contract Documents, the Engineer may, in writing, order the Contractor to stop the work, or any portion thereof, until the cause for such order has been eliminated. The Contractor shall immediately comply with a written order of the Engineer to stop the work. The work stopped shall be resumed as and when ordered by the Engineer.

G8.11 LIQUIDATED DAMAGES. The parties acknowledge that it would be impractical or extremely difficult, at the time of Contract formation, to ascertain the amount of damages for the injuries listed below. As a result, the parties agree that the Owner may collect liquidated damages, as set forth in this General Condition and in other provisions of the Contract. The assessment of liquidated damages under this provision shall not preclude recovery by the Owner of other damages subject to reasonable quantification, including consequential damages. Consequential and other damages not provided for by this liquidated damages provision may include, but are not limited to, first- and third-party claims for personal injuries and/or property damages, inverse condemnation, environmental claims, or regulatory fees or fines imposed in whole or in part due to Contractor's acts or failures to act.

Liquidated damages shall be deducted from the progress payments or from any other monies due to or to become due the Contractor. If the payments due the Contractor are less than the amount of such liquidated damages, the Contractor or its Surety shall pay the balance to the Owner.

A. Failure to Meet Completion Dates. It is agreed by the parties to the Contract that in case all the work called for under the Contract in all parts and requirements is not completed within the number of days as set forth in the Special Conditions, damage will be sustained by the Owner and that it is and will be impracticable and extremely difficult to ascertain and determine the actual damage which the Owner will sustain in the event of and by reason of such delay; and it is therefore agreed that the Contractor shall pay to the Owner (as liquidated damages for delay and not as a penalty) the sum set forth in the Special Conditions per day for each and every calendar day's delay in finishing the work in excess of the number of days prescribed; and the Contractor agrees to pay said liquidated damages herein provided for, and further agrees that the Owner may deduct the amount thereof from any monies due or that may become due the Contractor under the Contract.

In addition, the Owner shall have the right to charge to the Contractor and to deduct from the final payment for the

work the actual cost to the Owner of engineering, inspection, administration and other overhead expenses which are directly chargeable to the Contract and which accrue during the period of such delay, except that the cost of final surveys and preparation of the final estimate shall not be included in such charges.

B. Public Hardships or Community Impacts. The Owner may also collect liquidated damages in the event that the Contractor fails to comply with Contract requirements in the following areas:

1. Traffic Control
2. Work Hours
3. Public Notification
4. Environmental Compliance

It is recognized that it is and will be impractical to ascertain and determine the exact amount of damages that the Owner and the public will suffer as a result of the public hardships or negative impacts caused by the Contractor's failure to comply with Contract requirements in the aforementioned areas. The factors relating to the impracticability of ascertaining a monetary value for such hardships or negative impacts include, but are not limited to, the fact that: (i) it is difficult to calculate all actual time spent by Owner staff, management, consultants, and other public agencies in dealing with the public hardship or negative impact; (ii) such public hardships or negative impacts cause economic losses, inconvenience, anxiety, and frustration to individual members of the general public in varying degrees of intensity that bear on the Owner and that are incapable of measurement in precise monetary terms; and (iii) the public hardship or negative impact is cumulative with each occurrence. Therefore, the Contractor and the Owner mutually agree that the amounts set forth in the Special Conditions are reasonable as liquidated damage amounts for each situation creating public hardship or negative impact. These liquidated damages are separate and distinct from any other damages subject to quantification that result from the Contractor's activities.

G8.12 DELAYS AND EXTENSIONS OF TIME. The Contractor will be granted an extension of time and will not be assessed with liquidated damages or the cost of engineering and inspection for any portion of the delay in completion of the work beyond the time set forth in the Special Conditions caused by unforeseeable causes beyond the control and without the fault or negligence of the Contractor or subcontractor. Examples of such causes include acts of God or of the public enemy, fire, floods, storms, epidemics, quarantine restrictions, strikes and other work stoppages caused by a labor dispute, shortage of materials and freight embargoes, changes made under Section G4.03 ("Changes") or acts or neglect of the Owner or Engineer not contemplated by the Contract Documents. In all cases, any extension of time is conditional on the following: (1) that the cause is not due to the fault of the Contractor or subcontractor and the Contractor has taken reasonable precautions to prevent delays due to such cause and (2) that the Contractor notifies the Engineer in writing within fifteen (15) days from the beginning of such delay specifying the nature of the delay, the number of days actually delayed and the measures taken to prevent or minimize the delay. Failure to submit written notice within this time shall constitute an absolute waiver of any claim for a time extension; failure to submit the required information will be sufficient cause for denial of the request for a time extension.

No extension of time will be granted for a delay caused by a shortage of materials, unless the Contractor furnishes to the Engineer documentary proof that he has diligently made every effort to obtain such materials from all known sources within reasonable reach of the work and further proof, in the form of schedule data as required in Section G8.05, that the inability to obtain such materials when originally planned did in fact cause a delay in final completion of the entire work which could not be compensated for by revising the sequence of the Contractor's operations. Only the physical shortage of material will be considered as a cause for extension of time, and no consideration will be given to any claim that material could not be obtained at a reasonable, practical or economical cost or price, unless it is shown to the satisfaction of the Engineer that such material could have been obtained only at exorbitant prices entirely out of line with current rates, taking into account the quantities involved and the usual practices in obtaining such quantities.

The term "shortage of materials," as used in this Section, shall apply only to materials, articles, parts or equipment which are standard items and shall not apply to materials, parts, articles or equipment which are processed, made, constructed, fabricated or manufactured to meet the specific requirements of the contract.

No extension of time will be granted for storms or adverse weather conditions which may reasonably be anticipated for the area in which the work is being performed, based on official records of monthly precipitation and other historical data.

No extensions of time will be granted for delays which have no measurable impact on the completion of the total work under the Contract. When extensions of time are granted, they will be limited to the period equivalent to the actual number of days lost on the critical path or controlling operation of construction, taking into account the extent to which that delay could be decreased by reasonable mitigation measures by the Contractor or its subcontractor.

Within a reasonable period of time after the Contractor submits the notice and information required by this Section, the Engineer will present his written opinion to the Owner as to whether an extension of time is justified and, if so, his recommendation as to the number of days for the extension. The Owner will make the final decision on all requirements for extension of time.

The Contractor shall have no claim for damage or compensation for any delay or hindrance and shall be fully compensated by an extension of time provided as set forth in this Section. Notwithstanding the preceding sentence, the Contractor may submit a claim for delay caused by acts or omissions of the Owner but only if such acts or omissions (1) results in a project delay to the critical path which is unreasonable in the circumstances and (2) are not such as to be within the contemplation of the parties. It is expressly agreed that delays by the Owner in providing access to the work site are not within the contemplation of the parties but that delays by the Owner in reviewing shop drawings and submittals and the risk of delays due to errors or omissions in the Contract Drawings are within the contemplation of the parties as expectable events in the construction process.

G8.13 TERMINATION OF RIGHT TO PROCEED. If the Contractor should appear to the Engineer to be in default and the Contractor fails to remedy his default within ten (10) days after receipt from the Engineer of notice of such default, the Owner may terminate the Contractor's right to proceed with the work or that portion which the Engineer determines is most directly affected by the default.

The term "default" for purposes of this Section includes, but is not limited to, the performance of work in violation of the terms of the Contract; abandonment, assignment or subletting of the Contract without approval of the Owner; bankruptcy or appointment of a receiver for Contractor's property; refusal or failure properly to prosecute the work; use of materials, supplies, plant or equipment of improper quality or quantity; refusal or failure to use an adequate number of properly skilled workers; failure to provide proper workmanship; failure to take effective steps to end a prolonged labor dispute; and the performance of the Contract in bad faith.

Upon the Owner's termination of the Contractor's right to proceed with the work, or a portion of it, the Owner shall have the right to complete the work, or the portion involved, by whatever means and methods it deems expedient, including the hiring of others on such terms as the Owner deems advisable. The Owner shall have the right to take possession of the Contractor's materials, plant, tools, equipment and property of any kind provided by or on behalf of the Contractor for the purpose of the work, or a portion of them, without being responsible to the Contractor for fair wear and tear. The Contractor shall have no rights in such property during its use by the Owner. The Owner shall not be required to obtain the lowest prices for completing the work or a portion of it but shall make such expenditures as, in the Owner's sole judgment, best accomplish such completion.

The expense of completing such work or portion thereof, together with a reasonable charge for engineering, managerial and administrative services, as certified by the Owner, shall be charged to the Contractor, and the expense so charged shall be deducted by the Owner out of such monies as may be due or may at any time thereafter become due to the Contractor. In case such expense is more than the sum which otherwise would have been payable to the Contractor under the Contract, then the Contractor or his surety or sureties shall promptly pay the amount of such excess so due. The Owner may, in its sole discretion, withhold all or any part of any progress payments otherwise due the Contractor until completion and final settlement of the work covered by such notice of default.

G8.14 TERMINATION OF CONTRACT. The Owner may terminate the Contract if the Contractor:

- A. Persistently or repeatedly fails or refuses to supply enough properly skilled workers or proper

materials;

- B. Fails to make payment to subcontractors for materials or labor in accordance with the respective agreements between the Contractor and subcontractor;
- C. Persistently disregards laws, ordinances or rules, regulations or orders of a public authority having jurisdiction; or
- D. Otherwise is guilty of a substantial breach of a provision of the Contract Documents. A "default" as defined in Section G8.12 shall constitute a substantial breach of the Contract Documents.

When any of the above reasons exist, the Owner may, without prejudice to any other rights or remedies of the Owner under this Contract or otherwise, upon ten (10) days, written notice, terminate the Contract and may:

- A. Take possession of the site and of all materials, equipment, tools and construction equipment and machinery thereon owned by the Contractor;
- B. Finish the work by whatever means the Owner deems expedient.

When the Owner terminates the Contract under this Section, the Contractor shall not be entitled to receive any further payments until the work is completed and accepted by the Owner.

The conditions of the last two paragraphs of Section G8.13 shall apply if the Owner terminates the Contract.

The Owner will issue the Contractor a written notice specifying that the Contract is to be terminated. Upon receipt of said written notice and, except as otherwise directed in writing by the Engineer, the Contractor shall:

- A. Stop all work under the Contract except that specifically directed to be completed prior to acceptance;
- B. Perform work the Engineer deems necessary to secure the project for termination;
- C. Remove equipment from the site of work;
- D. Take such action as is necessary to protect materials from damage;
- E. Notify all subcontractors and suppliers that the Contract is being terminated and that their contracts or orders are not to be further performed unless otherwise authorized in writing by the Engineer;
- F. Provide the Engineer with an inventory list of all materials previously produced, purchased or ordered from suppliers for use in the work and not yet used in the work, including its storage location, and such other information as the Engineer may request;
- G. Dispose of materials not used in the work as directed by the Engineer. It shall be the Contractor's responsibility to provide the Owner with good title to all materials purchased by the Owner here under, including materials for which partial payment has been made as provided in Section G9.10, "Partial Payments," of these General Conditions and with bills of sale or other documents of title for such materials;
- H. Subject to the prior written approval of the Engineer, settle all outstanding liabilities and all claims arising out of subcontracts or orders for materials terminated here under. To the extent directed by the Engineer, the Contractor shall assign to the Owner all the right, title and interest of the Contractor under subcontracts or orders for materials terminated here under;
- I. Furnish the Engineer with the documentation required to be furnished by the Contractor under the conditions of the Contract including, on projects as to which federal funds are involved, all documentation required under the federal requirements included in the Contract;

J. Take such other actions as the Engineer may direct.

G8.15 EXISTING UTILITIES. In general, the location of existing utilities, whether aboveground or underground, are indicated on the drawings. This information has been obtained from utility maps and from verbal descriptions provided by the various agencies involved. The Owner does not guarantee the accuracy or completeness of this information and it is to be understood that the other aboveground or underground facilities not shown on the drawings may be encountered during the course of the work.

The Contractor shall call the Underground Services Alert Agency and notify the underground utility companies of his intention to work in the vicinity of their service and shall enlist their help to pinpoint the exact location, both in plan and elevation, of their utility. Except as otherwise provided in this Article any required relocation of existing underground utility or special construction techniques required in order to avoid existing utilities shall be performed by the Contractor at no increase in cost to the Owner.

Pursuant to California Government Code Section 4215 the Owner shall assume the responsibility for the timely removal, relocation, or protection of the existing main or trunkline utility facilities located on the construction site if such utilities are not identified by the Owner in the plans and specifications. The Owner shall compensate the Contractor for the costs of locating such utility facilities, repairing damage not due to the failure of the Contractor to exercise reasonable care, and removing or relocating such utility facilities not indicated in the plans and specifications with reasonable accuracy; and for the cost of equipment necessarily idled. However, the Contractor shall make all reasonable efforts to minimize and or mitigate the costs he or she incurs in locating utility facilities not identified by the Owner or for equipment necessarily idled. The Contractor shall not be assessed liquidated damages for delay in completion of the work when such delay was caused by the failure of the Owner or the owner of the utility to provide for removal or relocation of such utility facilities.

Owner is not responsible for indicating the presence of existing service laterals or appurtenances whenever the presence of such utilities can be inferred from the presence of visible facilities, such as buildings, meter and junction boxes, on or adjacent to the construction site.

If the Contractor discovers utility facilities not identified by the Owner in the contract plans or specifications, he shall immediately notify the Owner and the utility in writing.

Existing aboveground utilities, including but not limited to, power transmission and distribution, telegraph, telephone and traffic control systems, whether shown on the drawings or not, shall be maintained, relocated, rerouted, removed and restored as may be necessary by the Contractor with the least possible interference with the use of such facilities at no increase in cost to the Owner.

The right is reserved by the owners of utilities and franchises to enter upon any street, right-of-way or easement for the purpose of maintaining their property and for making necessary repairs or changes caused by the work. The Contractor shall pay all costs thus incurred.

G8.16 TEMPORARY UTILITIES. The Contractor shall make his own arrangements with utility companies for any services he may require in performance of the work of this Contract and shall pay all costs of these services directly to these utility organizations.

G8.17 OFFICE OF CONTRACTOR AT SITE. During the performance of the Contract, Contractor shall maintain a suitable office at the site of work which shall be the headquarters of a representative authorized to receive drawings, instructions or other communications from the Owner or Owner's agents; any such thing given to said representative or delivered at the Contractor's office at the site of work in his absence shall be deemed to have been given to the Contractor. Contractor shall maintain a complete set of plans and specifications at the site office whenever work is in progress.

G8.18 PRESERVATION OF STAKES AND MARKS. Contractor shall preserve carefully bench marks, reference points, and stakes; in case of willful or careless destruction, he will be charged with the resulting expense of replacement and shall be responsible for any mistakes that may be caused by their unnecessary loss or disturbance.

G8.19 SUGGESTIONS TO CONTRACTOR. Any plan or method of work suggested by the Engineer to the Contractor, but not specified or required, if adopted or followed by the Contractor in whole or in part, shall be used at the risk and responsibility of the Contractor, and the Engineer and the Owner shall assume no responsibility thereof.

G8.20 USE OF EXPLOSIVES. When the use of explosives is necessary for the work, Contractor shall use the utmost care not to endanger life or property. Before blasting operations are undertaken, at least twenty-four (24) hours written notice must be given to the Owner and Engineer. Contractor will be responsible for obtaining permits from appropriate authority.

No explosive material shall be transported to, stored or utilized on the site without written permission of Engineer. Only qualified persons who possess a valid permit shall do all blasting work and handling of explosives on the site.

SECTION 9

MEASUREMENT AND PAYMENT

G9.01 MEASUREMENT OF QUANTITIES. All work to be paid for at a Contract price per unit of measurement will be measured by the Engineer in accordance with United States Standard Measures. Pipelines shall be measured horizontally.

G9.02 SCOPE OF PAYMENT. The Contractor shall accept the compensation provided in the Contract as full payment for furnishing all labor, materials, tools, equipment and incidentals necessary to the completed work and for performing all work contemplated and embraced under the Contract; also for loss or damage arising from the nature of the work, or from the action of the elements, or from any unforeseen difficulties which may be encountered during the prosecution of the work until the acceptance by the Owner; and for all risks of every description connected with the prosecution of the work, also for all expense incurred in consequence of the suspension or discontinuance of the work as herein specified; and for completing the work according to the Contract Documents. Neither the payment of any estimate nor of any retained percentage shall relieve the Contractor of any obligation to make good any defective work or materials.

No compensation will be made in any case for loss of anticipated profits.

Except as specifically provided otherwise, no separate payment will be made for work covered in any of these General Conditions and the cost thereof will be considered as included in the prices paid for the various Contract items included in the Bid.

If the "payment" clause in the Contract Documents relating to any unit price in the bid schedule requires that the said unit price cover and be considered compensation for certain work or material essential to the item, this same work or material will not also be measured nor paid for under any other pay item which may appear elsewhere in the Contract Documents.

G9.03 FORCE ACCOUNT PAYMENT. When extra work or other work done pursuant to a Change Order is to be paid for on a force account basis, materials and equipment used in the performance of such work shall be subject to the approval of the Engineer and compensation will be determined as set forth in Section 9-1.03 of the Standard Specifications.

Equipment idled or on standby during a compensable delay will have the right-of-way delay factor applied in accordance with the CalTrans publication, "Labor Surcharge and Equipment Rental Rates." Compensable delays include delays owing to differing site conditions, utility interferences, interferences by other contractors or utility companies, or other delays beyond the control of the Contractor. For equipment not included in the CalTrans publication, the standby rate will be determined by the Blue Book's monthly rental rates divided by 173 less any operating expenses.

G9.04 RECORDS. The Contractor shall maintain his records in such a manner as to provide a clear distinction between the direct costs of work paid for on a force account basis and the costs of other operations.

From the above records, the Contractor shall furnish the Engineer completed daily reports, on forms furnished by or acceptable to the Owner, for each day's work to be paid for on a force account basis. The daily reports shall itemize the materials used, and shall cover the direct cost of labor and the charges for equipment rental, whether furnished by the Contractor, subcontractor, or other forces, except for charges described in Section G9.03 "Force Account Payment," of the General Conditions. The daily reports shall provide names or identifications and classifications of workers, the hourly rate of pay and hours worked, and also the size, type and identification number of equipment, and hours operated. Before presenting the daily reports to the Engineer for payment, the Contractor shall compile the cost of the work to be paid for on a force account basis. The report number shall be left blank for completion by the Engineer.

Material charges shall be substantiated by valid copies of vendor's invoices. Such invoices shall be submitted with

the daily reports, or if not available, they shall be submitted with subsequent daily reports. Should vendor's invoices not be submitted within sixty (60) days after the date of delivery of the materials or within fifteen (15) days after the acceptance of the Contract, whichever occurs first, the Owner reserves the right to establish the cost of such materials at the lowest current wholesale prices at which said materials are available in the quantities concerned delivered to the location of the work, less any discounts provided in Section G9.03.

The daily reports shall be signed by the Contractor or his authorized representative.

The Engineer will compare his records with the completed daily reports furnished by the Contractor and make any necessary adjustments.

When the daily reports are agreed upon and signed by both parties, the reports shall become the basis of payment for the work performed, but shall not preclude subsequent adjustment based on the later audit by the Owner.

G9.05 NOTICE OF POTENTIAL CLAIM. The Contractor shall not be entitled to the payment of any additional compensation for any cause, including any act, or failure to act, by the Engineer (including the failure or refusal to issue a Change Order), or the happening of any event, thing or occurrence, unless he shall have given the Engineer due written notice of potential claim as hereinafter specified, provided, however, that compliance with this Section shall not be a prerequisite as to matters within the scope of the Contract Change Order protest conditions in Section G4.08, "Protest Procedure," or the notice conditions in Section G8.12, "Delays and Extension of Time," nor to any claim which is based on differences in measurement or errors of computation as to correct quantities.

The written notice of potential claim shall set forth the reasons for which the Contractor believes additional compensation will or may be due, the nature of the costs involved and, insofar as possible, the amount of the potential claim. If based on an act or failure to act by the Engineer or the Owner, such notice shall be given to the Engineer prior to the time that the Contractor has started performance of the work giving rise to the potential claim for additional compensation. In all other cases, notice shall be given within fifteen (15) days after the happening of the event or occurrence giving rise to the potential claim.

It is the intention of this Section that differences between the parties arising under and by virtue of the Contract shall be brought to the attention of the Engineer at the earliest possible time in order that such matters may be settled if possible, or other appropriate action promptly taken. The Contractor hereby agrees that he shall have no right to additional compensation for any claim that may be based on any such act, failure to act, event, thing or occurrence for which a written notice of potential claim as herein required was not timely filed.

G9.06 STOP NOTICES. The Owner may, at its option and at any time, retain out of any amounts due the Contractor sums sufficient to cover claims filed pursuant to Section 3081 et seq. of the California Civil Code.

G9.07 PAYMENT SCHEDULES. The Contractor shall submit a Schedule of Anticipated Contract Payments and a Schedule of Pay Items for review and approval by the Engineer prior to the initial partial payment to the Contractor. The Schedule of Pay Items shall be prepared by the Contractor in a format approved by the Engineer and shall include such detail as directed by the Engineer. The Schedule shall be sufficiently clear and detailed so as to facilitate an accurate and realistic appraisal of monthly progress for the purpose of making partial payments. The value for each bid item shall total the bid amount. The values in the Schedule will be used only for determining partial payments.

The Schedule of Anticipated Contract Payments shall be coordinated by the Contractor's construction schedule submitted pursuant to Section G8.05 and shall show the anticipated monthly Contract payments for each of the pay items covered in the Schedule for Pay Items, the total of monthly payments and cumulative total of payments for each month. If the construction schedule is revised, the Schedule of Anticipated Contract Payments shall also be revised and resubmitted for the Engineer's review and approval. No partial payment will be made until the Engineer has approved the Schedules required by this Section.

G9.08 INVOICE FOR WORK COMPLETED. Once each month, at a time, place and location mutually agreeable, the Contractor and Engineer shall meet to discuss the amount of work completed satisfactorily during the work period since the last invoice for partial payment was prepared. A draft invoice for work completed shall be

prepared; the Engineer's judgment will be final if disputes occur regarding the amount of work completed or its value. Following the meeting, the Contractor shall formally submit the invoice for work completed in a form acceptable to the Engineer. The invoice will certify, and be supported by evidence if required by the Engineer, that the work invoiced has been done and that the materials listed are at the storage places indicated. The invoice may include the amount and value of such acceptable material as has been furnished and delivered to the site or has been furnished and stored for use in the work, provided it is stored within the general work area and is designated for incorporation in the work.

G9.09 RETENTION. In addition to amounts, if any, withheld pursuant to any other provision of these General Conditions, including the Owner's right to withhold for the estimated or actual costs of correcting defective work and amounts claimed by the Owner as liquidated damages or other offsets, the Owner will retain an amount equal to 10 percent of the estimated value of the work done and ten (10) percent of the value of materials estimated to have been furnished and delivered and unused or furnished and stored as aforesaid as part security for the fulfillment of the Contract by the Contractor.

G9.10 PARTIAL PAYMENTS. Each acceptable Contractor's invoice will be paid within thirty (30) days of the Engineer's receipt of the invoice, after deducting all previous payments, retentions, and other sums as described in the Contract Documents. No such payment will be made when, in the judgment of the Engineer, the work is not proceeding in accordance with the conditions of the Contract, or when the total value of the work done as shown on the invoice does not exceed five hundred dollars.

No such invoice nor payment will be construed to be an acceptance of any work or materials.

G9.11 PAYMENT OF WITHHELD FUNDS. Upon the Contractor's request, the Owner will make payment of funds withheld from progress payments as described in Section G9.09, pursuant to the requirements of Public Contract Code Section 22300, if the Contractor deposits in escrow with the Owner or with a bank acceptable to the Owner, securities eligible for investment under Government Code Section 16430, bank or savings and loan certificates of deposit, interest bearing demand deposit accounts, standby letters of credit, or any other security mutually agreed to by the Contractor and the Owner, upon the following conditions:

- A. The Contractor shall bear the expense of the Owner and the escrow agent in connection with the escrow deposit made.
- B. Securities or certificates of deposit to be placed in escrow shall be of a value at least equivalent to the amounts of retention to be paid to the Contractor pursuant to this section.
- C. The Contractor shall enter into an escrow agreement satisfactory to the Owner, which agreement shall be substantially similar to the form provided in Public Contract Code Section 22300.
- D. The Contractor shall obtain the written consent of the surety to such agreement.

G9.12 FINAL PAYMENT AND CLAIMS. After the work has been accepted by the Owner, as provided in Section G7.30, "Acceptance of Work," payment will be made to the Contractor in accordance with the conditions of this Section. Upon acceptance, the Owner will record a Notice of Completion covering the project.

Within thirty (30) days after acceptance by the Owner, the Contractor shall prepare and submit a proposed final invoice in writing, prepared in a form acceptable to the Engineer. The proposed final invoice will show the proposed total amount of compensation payable to the Contractor, including an itemization of that amount segregated as to Contract item quantities, extra work and other bases for payment. The proposed final invoice will also show all deductions made or to be made for prior payments and amounts to be kept or retained under the Contract.

The Contractor shall also submit, at the same time as the proposed final invoice is submitted, a statement of all claims he has arising under or by virtue of the Contract, or a statement that he does not intend to file any such claims. No claim for which a notice of potential claim or protest is required under Section G9.05, "Notice of Potential Claim," Section G4.08, "Protest Procedure," or Section G8.12, "Delays and Extension of Time," will be

considered unless the Contractor has fully complied with the notice or protest requirements in said sections.

Claims filed by the Contractor shall be in sufficient detail to enable the Engineer to ascertain the basis and amount of said claims. The Engineer will consider and determine the Contractor's claims and it will be the responsibility of the Contractor to furnish within a reasonable time such further information and details as may be required by the Engineer to determine the facts or contentions involved in the claims. Failure to submit such information and details will be sufficient cause for denying the claims. The procedure for the consideration of all claims is set forth below in Section G9.13 "Claims Procedures."

The Engineer will review the proposed final invoice and claims and will submit his recommendation to the Owner as to the final estimate of the amount due the Contractor and the disposition of all claims. All prior invoices and payments are subject to correction in connection with review of the proposed final invoice.

The Owner will submit any changes or corrections to the proposed final invoice to the Contractor for his consideration. Within ten (10) days thereafter, the Contractor shall submit a final invoice, in a form acceptable to the Engineer, incorporating any changes or corrections made by the Owner, together with any additional claims resulting therefrom. Upon approval by the Owner, this will become the approved final invoice. The Contractor shall submit with the final invoice, certificates of any insurance required to be maintained after acceptance of the work.

If the Contractor files no claims within thirty (30) days after acceptance of the work by the Owner, and agreement is reached on all questions regarding the final invoice, the Owner will pay the entire sum found due upon the final invoice, except that the Owner will withhold sums sufficient to pay all unsettled claims for which stop notices have been filed pursuant to Section 3081 et seq. of the California Civil Code, together with the costs of administering such claims.

If the Contractor does file claims within thirty (30) days after acceptance of the work by the Owner, then upon final determination of all the Contractor's claims, the Owner will pay the entire sum found due upon the final invoice, including the amount, if any, allowed on claims, except that the Owner will withhold sums sufficient to pay all unsettled claims for which stop notices have been filed pursuant to Section 3081 et seq. of the California Civil Code, together with the costs of administering such claims.

Final payment will be made within thirty (30) days after receipt of an approved final invoice and determination of all Contractor's claims, or sixty (60) days after acceptance of the work by the Owner, whichever is later, provided, however, that if an approved final invoice has not been submitted within sixty (60) days after acceptance of the work by the Owner, the Owner may elect to make payment of sums not in dispute without prejudice to the right of either the Owner or the Contractor in connection with such disputed sums.

The acceptance by the Contractor of final payment shall constitute a waiver and release of all claims by the Contractor against the Owner related to the work, except for claims previously made in writing and identified as unsettled by the Contractor at the time of submission of the final invoice. The making of final payment, however, shall not operate to release the Contractor or his sureties from obligations arising under this Contract, the Contract bonds and warranties as herein provided. Specifically, the making of final payment shall not constitute a waiver and release of claims by the Owner arising from (a) unsettled or future liens, (b) failure of the work to comply with the requirements of the Contract Documents, (c) the terms of any warranties required by or contained in the Contract Documents, (d) the right to any insurance proceeds or the right to make any insurance or bond claims, (e) any claims with respect to Contractor's obligation of indemnity provided for in the Contract Documents, or (f) any latent defects or fraud.

G9.13 CLAIMS PROCEDURES

A. The Contractor's and subcontractors' attention is directed to Government Code Section 900 et seq. dealing with claims and actions against public entities and employees. Nothing contained in the Contract, including but not limited to, this General Condition, is intended to modify or remove the requirements set forth in these Government Code sections.

B. The presentation of any claim by the Contractor shall be accompanied by the following certification: :

"CONTRACT PROVISION REQUIRING PERSONAL CERTIFICATION OF ALL CLAIMS"

I, _____, BEING THE _____
(MUST BE AN OFFICER) OF _____ (GENERAL CONTRACTOR), DECLARE UNDER PENALTY OF PERJURY UNDER THE LAWS OF THE STATE OF CALIFORNIA, AND DO PERSONALLY CERTIFY AND ATTEST THAT: I HAVE THOROUGHLY REVIEWED THE ATTACHED CLAIM AND KNOW ITS CONTENTS, AND SAID CLAIM IS MADE IN GOOD FAITH; THE SUPPORTING DATA IS TRUTHFUL AND ACCURATE; THAT THE AMOUNT REQUESTED ACCURATELY REFLECTS THE CONTRACT ADJUSTMENT FOR WHICH THE CONTRACTOR BELIEVES THE OWNER IS LIABLE; AND, FURTHER THAT I AM FAMILIAR WITH CALIFORNIA GOVERNMENT CODE SECTION 12650, ET SEQ. PERTAINING TO FALSE CLAIMS, AND FURTHER KNOW AND UNDERSTAND THAT SUBMISSION OR CERTIFICATION OF A FALSE CLAIM MAY LEAD TO FINES, IMPRISONMENT AND/OR OTHER SEVERE LEGAL CONSEQUENCES."

Signed:

Date

C. Owner incorporates by reference Section 20104, et. seq, of the Cal. Public Contract Code as if fully set forth herein. For claims of less than fifty thousand dollars (\$50,000), the Owner will respond in writing within 45 days of its receipt of the claim, or may request, in writing, within 30 days of its receipt of the claim, submission of additional documentation supporting the claim or relating to defenses or claims the Owner may have against the Contractor.

1. If such additional documentation is requested by the Owner, it shall be provided by the Contractor within 20 days of its receipt of the request from the Owner or as otherwise mutually agreed upon by the Owner and the Contractor.
2. Following the Contractor's submission of all requested additional documentation, the Owner will respond to the claim within 15 days or within the period of time taken by the Contractor in producing the additional documentation, whichever is longer.

D. For claims of over fifty thousand dollars (\$50,000) and less than or equal to three hundred seventy-five thousand dollars (\$375,000), the Owner will respond in writing within 60 days of its receipt of the claim, or may request, in writing, within 30 days of receipt of the claim, submission of additional documentation supporting the claim or relating to defenses or claims the Owner may have against the Contractor.

1. If such additional documentation is requested by the Owner, it shall be provided by the Contractor within 30 days of its receipt of the request or as otherwise mutually agreed upon by the Owner and the Contractor.
2. Following the Contractor's submission of all requested additional documentation, the Owner will respond to the claim within 30 days, or within the period of time taken by the Contractor in producing the additional documentation, whichever is longer.

E. If the Contractor disputes the Owner's written response, or if the Owner fails to respond within the time prescribed, the Contractor may so notify the Owner, in writing, either within fifteen (15) days of receipt of the Owner's response or within fifteen (15) days of the Owner's failure to respond within the time prescribed, respectively, and demand an informal conference to meet and confer for settlement of the issues in dispute. Upon receiving such a demand, the Owner shall schedule a meet and confer conference within (thirty) 30 days.

F. If, following the meet and confer conference, the claim or any portion remains in dispute, the Contractor may file a claim pursuant to Chapter 1 (commencing with Section 900) and Chapter 2 (commencing with Section 910) of Part 3 of Division 3.6 of Title 1 of the Government Code. For purposes of those provisions, the running of the period of time within which a claim must be filed shall be tolled from the time the Contractor submits its written claim pursuant to paragraph 2 above until the time said claim is denied pursuant to the procedures set forth herein, including any period of time utilized by the meet and confer conference.

G. For claims exceeding three hundred seventy-five thousand dollars (\$375,000), the Owner may request, in writing, within 60 days of receipt of the claim, submission of additional documentation supporting the claim or relating to defenses or claims the Owner may have against the Contractor.

1. If such additional documentation is requested by the Owner, it shall be provided by the Contractor within 45 days of its receipt of the request or as otherwise mutually agreed upon by the Owner and the Contractor.
2. Following the Contractor's submission of all requested additional documentation, the Owner will respond to the claim within 45 days, or within the period of time taken by the Contractor in producing the additional documentation, whichever is longer.

H. The Owner, at its exclusive discretion, may schedule a meet and confer conference within 60 days for settlement of the dispute of claims exceeding three hundred seventy-five thousand dollars (\$375,000).

I. Following the meet and confer conference, if the claim or any portion remains in dispute, the claimant may file a claim as provided in Chapter 1 (commencing with Section 900) and Chapter 2 (commencing with Section 910) of Part 3 of Division 3.6 of Title 1 of the Government Code. The period of time within which to file a claim pursuant to Government Code Section 910 is not tolled for claims exceeding three hundred seventy-five thousand dollars (\$375,000), nor does this procedure change the period of time for filing claims pursuant to Government Code Section 910. .

Doc. 810185v1

(This page left blank intentionally)

PART III

SPECIAL CONDITIONS

STEGE SANITARY DISTRICT
PROJECT NO. 12201
JULY 2012

(This page left blank intentionally)

SECTION 1

SPECIAL CONDITIONS

S1.01 PATENTS, ROYALTIES, LICENSING (ADDITIONAL CONDITIONS). In addition to the requirements regarding patents outlined in the General Conditions and Technical Conditions, specific attention of the Contractor is directed to the following information:

1. The pipe replacement work called for on this project will require the Contractor to use a trenchless method of construction.
2. Some forms of trenchless pipe replacement construction are referred to as “pipe bursting” or “pipe cracking”.
3. The District has been notified by British Gas, 100 Thames Valley Park Drive, Reading, Berkshire, RG6 1PT, Great Britain, that it holds U.S. Patent No. 4738565, which British Gas contends covers pipe bursting or pipe cracking methodologies.
4. The District is unable to determine whether any form of trenchless pipe replacement that may be permitted by these project Specifications would be covered by the British Gas patent or by any other patent or intellectual property right claim. However, pursuant to the provisions of the General Conditions, Section G7.12, it is the obligation of the Contractor to take whatever measures, including the acquisition of licenses or other rights of use, which are required with respect to any such patents or intellectual property right claims and to defend, indemnify and hold the District harmless from any such patents or claims without any cost or expense to the District.

S1.02 REPRESENTATIVE SEWER REHABILITATION SECTION: The project specifies two types of representative sections: A representative Right-of-Way section and a representative Easement section.

S1.02A REPRESENTATIVE SEWER REHABILITATION RIGHT-OF-WAY SECTION

The representative Right-of-Way section is located in the public Right-of-Way, typically a paved street or sidewalk. Excavations at these locations can be performed by construction equipment. The Right-of-Way site condition shall consist of a paved environment and work will require, but will not be limited to, CCTV inspection, existing utility location & protection, potholing, saw cutting, no-parking sign posting & public noticing, traffic control, sheeting & shoring, providing temporary protection such as steel plates & cutback, backfill, offhaul & disposal of unsuitable excavated material, and resurfacing & striping restoration to City/County specification as required. For bid purposes, the cost of the work for the representative Right-of-Way section shall be based on the section as shown on the plans consisting of

1. 200 LF of existing pipe, 8 feet deep.
2. Re-connecting and sealing two (2) connections to existing manholes.
3. Locating and re-connecting four (4) lateral connections.
4. Excavation, bedding, backfill, compaction and surface restoration (including CCTV inspection, labor, equipment, sheeting and shoring and all disposal).
5. Existing utility location & protection, potholing, saw cutting, no-parking sign postings and public noticing, traffic control, sheeting & shoring, temporary protection (steel plates, cutback, etc), and striping restoration shall be included in the various bid items in this specification to replace or repair pipe and no additional payment shall be made for the aforementioned items.

6. Resurfacing fees (aka Moratorium fees) and permitting fees shall be paid by the District. No payment shall be made by the District above and beyond the actual cost of the fees or permit.

S1.02B REPRESENTATIVE SEWER REHABILITATION EASEMENT SECTION

The representative section is located in an easement that shall have limited access and requires excavation by hand and the transport of equipment and material by hand. The easement site condition shall consist of a bare environment with no structures and requiring minimal surface restoration. For bid purposes, the cost of the work shall be based on the representative section as shown on the plans consisting of

1. 200 LF of existing pipe, 8 feet deep.
2. Re-connecting and sealing two (2) connections to existing manholes.
3. Locating and re-connecting four (4) lateral connections.
4. Excavation, bedding, backfill, compaction and surface restoration (including CCTV inspection, labor, equipment, sheeting and shoring, temporary protection (steel plates, cutback, etc), and all disposal).

S1.03 VARIATIONS IN THE REPRESENTATIVE SEWER REHABILITATION SECTION

1. Size: District sewer lines consist predominantly of six (6) inch diameter vitrified clay pipe (VCP) but actual sizes will range from six (6) inch diameter up to twelve (12) inch diameter. The Contractor is required under this contract to perform rehabilitation of existing pipe with new pipe of the same internal diameter size. Pipe bursting six (6) inch diameter to eight (8) inch diameter may be substituted as directed by the Engineer.
2. Length: Actual pipe lengths to be pipe burst will vary from the representative bid of two hundred (200) feet. Payments for pipe lengths greater or less than two hundred (200) feet will be adjusted accordingly to the ratio of actual footage to two hundred (200) feet. Refer to Section S1.07 of these Special Conditions for price adjustments.
3. Depth: Actual pipe depths will vary from the representative bid of eight (8) feet deep. For pipe depths less than or equal to eight (8) feet deep, the minimum payment shall be the base bid price for the representative eight (8) foot deep section as shown in the Proposal. Payments for pipe depths in excess of eight (8) feet deep will be adjusted accordingly to the ratio of actual footage to eight (8) feet deep up to twelve (12) feet deep. Refer to Section S1.07 of these Special Conditions for price adjustments deeper than twelve (12) feet.

Sheeting, shoring, bracing, or sloped trench wall is required for trenches deeper than five (5) feet, and may be required for shallower trenches depending on site conditions. All applicable OSHA regulations must be followed.

4. Pipe Materials:

MAIN SEWER: High-Density Polyethylene pipe and fittings shall be PLEXCO EHMW PE 3408, SDR17, gray in color, or approved equal, consisting of virgin high molecular polyethylene, specified under ASTM D3350 as having a cell classification of PE 345434C.

Cured-in-place-pipe (CIPP) may be substituted as directed by the Engineer. See SECTION 2F of the Technical Conditions for approved CIPP materials.

LATERAL SEWER: Vitrified clay pipe (VCP), cast iron pipe (CIP) or High-Density Polyethylene pipe (HDPE), per Section 22.02 C. of the District Construction Specifications and Details.

5. Asphalt Concrete (AC) Paving: See bid items for fixed Bid price for the cost to remove and replace the AC paving and sub base for sections located in paved roadways. The cost shall include any temporary paving & protection that may be required and the disposal of replaced AC and sub base materials to an acceptable disposal site. Refer to Section 2C, Paving.
6. Site Condition Variations: Adjustments to the fixed Bid price will be made for sections which have site conditions that require significant, additional labor to execute. Examples of these conditions are fences, landscaping, and retaining walls that may interfere with the work and result in significant labor to remove, replace, or avoid. Refer to Section S1.07 of these Special Conditions for price adjustments.
7. Contract Change Order: Adjustments to the Bid Price due to variations from the representative section shall be made in accordance with contract change order provisions in Sections G4.03 through G4.09 of the General Conditions. Refer to Section S1.07 of these Special Conditions for price adjustments.

S1.04 CONTRACT DURATION: The Contractor shall be the District's primary Contractor for pipe bursting for a period of three hundred and sixty five (365) calendar days from the date of the start of work designated in the "Notice to Proceed" but may be extended, by mutual agreement, between the District and Contractor for an additional three hundred and sixty five (365) calendar days. The District reserves the right to use the services of other contractors who have bid when the Contractor is not available, cannot meet District schedules or, in the opinion of the District, the job is not within the scope of this agreement.

S1.05 CONTRACT AMOUNT: The total amount to be expended by the District during the contract period shall not exceed \$1,00,000. The total may be increased by approval of the District's Board of Directors. The District makes no representation or guarantee of the minimum amount to be spent by the District.

S1.06 INVOICE FORM: The Invoice Form, or approved equivalent, must be completed for all work. The actual length, diameter and average depth of pipe shall be indicated on the Form. The actual number of manhole and lateral connections, actual permit fees and any variations from the standard pipe burst shall also be indicated on this Form.

S1.07 PAYMENT: The fixed Bid price includes, but is not limited to, excavation, pipe, bedding, disposal of spoils, sheeting, shoring and bracing, backfilling, actual permit fees and miscellaneous incidentals necessary for successful completion of the pipe burst as described in the appropriate representative sewer rehabilitation section. The fixed Bid price may be adjusted in accordance with Section S1.03 of these Special Conditions in the following manner:

1. The Contractor is required to submit the Invoice Form, or approved equivalent, and indicate the actual size, depth, length of pipe installed, the actual number of manhole and lateral connections, actual permit fees and any variations from the standard pipe burst. Payments will be based upon the information submitted. Upon acceptance by the District and completion of a contract change order per Sections G.4.03 through 4.09 of the General Conditions, the Invoice Form shall be the basis of payment.
2. Adjustments included in the fixed Bid price will be made for actual amounts shown on the Invoice Form. Pipe bursting lengths shall be adjusted in accordance to the ratio of actual footage to two hundred (200) feet. Depths in excess of eight (8) feet shall be adjusted in accordance to the ratio of actual depth to eight (8) feet. The final adjusted figures approved by contract change order and included on the Invoice Form shall be the basis for payment.

S1.08 NOTIFICATION: The Contractor shall begin repair work within thirty (30) calendar days after receipt of notification of the need for repairs from the District. Failure by the Contractor to respond within seven (7) calendar days could result in the District awarding the repair work to another contractor. The District reserves the right to terminate the contract as outlined in S1.14 of these Special Conditions. The Contractor shall notify the District prior to initiation of work on a section.

S1.09 MOBILIZATION COSTS AND PAYMENT. Mobilization shall consist of preparatory work and operations, including, but not limited to, those necessary for the movement of personnel, equipment, supplies, and incidentals to the project site; for the establishment of facilities necessary for work on the project, and for all other work and operations which must be performed or costs incurred prior to beginning work on the various contract bid items.

The mobilization contract line item shall be paid as a lump sum price and shall not be determined or relate to the amount of pipe to be installed in any instance. Separate mobilization lump sum payments may be made for each individual jobsite, and jobsite shall refer to all work to be done within a location that consists of connected pipe reaches. The mobilization contract line item shall not be used for work independent of pipe bursting and complete pipe reach replacement activities such as spot/point repairs.

S1.10 PRELIMINARY INSPECTION

1. The Contractor shall perform a preliminary inspection prior to pipe bursting and will notify the District of inconsistencies in the scope of this contract. Failure to notify the District of inconsistencies could result in non-payment of any extra work.
2. The District will provide the Contractor with any available information such as video inspection tapes. However, the District does not guarantee the accuracy of any information supplied, nor does the furnishing of the information preclude the Contractor from performing the required preliminary inspection prior to performing the point repair work.

S1.11 TIME FOR COMPLETION: The maximum completion time allowed for each pipe burst is thirty (30) calendar days. Failure to complete repair work within thirty (30) calendar days shall be considered unsatisfactory performance by the Contractor and subject to the conditions of the termination of the contract as outlined in Section S1.14 of these Special Conditions. The District will consider extenuating circumstances such as excessive rainfall, adverse site conditions and retains the right to determine if the thirty (30) calendar days should be waived.

S1.12 OCCUPANCY PRIOR TO ACCEPTANCE. General Conditions, Section G7.30, Occupancy Prior to Acceptance. Add the following sentence to this section of the General Conditions: “Use of newly constructed sanitary sewers to carry sewage flow prior to project completion shall not constitute occupancy by the Owner. Occupancy shall not apply to newly constructed sanitary sewers unless they have been televised and passed the final inspection of the Engineer.”

S1.13 LIQUIDATED DAMAGES. Following are the amounts for liquidated damages to be assessed under General Condition G8.11, Liquidated Damages.

- A. Failure to Meet Completion Dates

The amount of liquidated damages for delays for which extensions of time have not been granted shall be as listed below for each day of delay beyond each of the required completion dates listed in the Contract.

ITEM	LIQUIDATED DAMAGE
Final Completion of All Work	\$ 250/day
Additional Milestone Dates	\$ 250/day

B. Public Hardship or Negative Impact

1. Traffic Control

Traffic control lasting beyond the prescribed times (applied on a per site, per day basis, and Technical Specifications).

First 15-minute interval	Warning
Second 15-minute interval	\$50
Each additional 15-minute interval or fraction thereof	\$100

2. Work Hours

Maintaining or running equipment outside the permitted hours (see Technical Specifications).

First occurrence	Warning
Second occurrence	\$ 150
Third and subsequent occurrences	\$ 250

3. Public Notification

Failure to comply with notification requirements for residents and commercial establishments in the Project area (see Technical Specifications).

First Occurrence	Warning
Second Occurrence	\$ 150
Third and Subsequent Occurrences	\$ 250

4. Environmental Compliance:

Failure to comply with the Storm Water Compliance requirements (see General Conditions).

First Occurrence	Warning
Second Occurrence	\$ 150
Third and Subsequent Occurrences	\$ 250

S1.14 CONTRACT TERMINATION

1. The District reserves the right to terminate the contract if, in the sole opinion of the District, the Contractor becomes nonresponsive or nonresponsible.
2. The Contractor is considered nonresponsive or nonresponsible if any of the following conditions occur during the contract period:
 - a. Contractor fails to respond within seven (7) calendar days after notification of the need for pipe bursting by the District, per Section S1.08 of these Special Conditions, on two (2) consecutive notifications.
 - b. Contractor fails to complete a pipe burst within thirty (30) calendar days, or otherwise fails to perform work satisfactorily within the scope of the Specifications. The District will consider any extenuating circumstances that may exist and reserves the right to waive

this thirty (30) calendar day limitation, as described in Section S1.11 of these Special Conditions.

3. The District reserves the right to waive any or all of the above conditions provided the Contractor can show evidence of valid reasons causing their failure to respond or perform work, and these reasons are acceptable to the District.

STEGE SANITARY DISTRICT
 (510) 524-4668 / (510) 524-4697 fax

INVOICE

STANDARD SEWER REHABILITATION PROJECT PROJECT #12201

PROJECT NAME/LOCATION: _____

Existing Pipe Diameter: _____ **IN. Ø** NEW Pipe Diameter: _____ **IN. Ø**

Average Pipe Depth: _____ **FEET** Rehab. Pipe Type: **[HDPE] • [CIPP]**

ITEM	QTY / UNIT	DESCRIPTION	UNIT PRICE	TOTALS
1.	- LUMP SUM -	MOBILIZATION, EXCAVATION, BEDDING, BACKFILL, COMPACTION AND SURFACE RESTORATION (INCLUDING LABOR, EQUIPMENT, SHEETING AND SHORING AND ALL DISPOSAL), COMPLETE IN PLACE, FOR THE LUMP SUM OF	\$	\$
2.	LF	[HDPE] • [CIPP] REHABILITATION OF EXISTING PIPE, COMPLETE IN PLACE, PER LINEAR FOOT AT	\$	\$
3.	EA	RECONNECT AND SEAL PIPE CONNECTIONS TO CONCRETE MANHOLE STRUCTURE, COMPLETE IN PLACE, EACH AT	\$	\$
4.	EA	LOCATE AND RECONNECT SEWER LATERALS, COMPLETE IN PLACE, EACH AT	\$	\$
5.	- LUMP SUM -	ACTUAL PERMIT FEES , FOR THE LUMP SUM OF	\$	\$
ADDITIONAL EXPENSES (MANHOLES, RODDING INLETS, LATERALS, CHANGE ORDERS):				
A.	EA		\$	\$
B.	EA		\$	\$
C.				\$
D.				\$
E.				\$
TOTAL INVOICE AMOUNT				\$

Submitted By: _____
Contractor *Date*

Approved By: _____
District *Date*

(This page left blank intentionally)

PART IV

TECHNICAL CONDITIONS

STEGE SANITARY DISTRICT
PROJECT NO. 12201
JULY 2012

(This page left blank intentionally)

SECTION 1A
INSTRUCTIONS

1. DEFINITIONS: Whenever any word or expression defined in this section, or pronoun used in its stead, occurs in these contract documents, it shall have and is mutually understood to have the meaning given:

- 1.1 Engineer: Engineer shall mean the Engineer of Work appointed by the District.
- 1.2 Construction Manager: Construction Manager shall mean the person appointed by the District to act as its representative at the construction site and to perform construction inspection services and administrative functions.
- 1.3 Standard Specifications: Standard Specifications shall mean the latest edition of the Standard Specifications of the California Department of Transportation.
- 1.4 Soils Consultant: The Geotechnical Engineer appointed by the District, acting either directly or through authorized agents for the preparation of the Geotechnical Report, field testing of the work and other particular duties entrusted to him.
- 1.5 District: District shall mean the Stege Sanitary District acting through the Board of Directors or any other board, body, official(s) to which or to whom the power belonging to the Board of Directors has been properly delegated.
- 1.6 Payment Bond: Payment Bond where used herein shall mean Labor and Material Bond.

2. LICENSING OF BIDDERS: Add the following paragraph to General Conditions, Section G2-13 Licensing of Bidders: “All Bidders shall hold an “A” (General), “C-34” (Pipeline), or “C-42” (Sanitation System) California Contractor’s License. Failure to hold required license shall be sufficient basis to consider Bidder’s Proposal unresponsive.”

3. PERMITS: Any costs for permits which the Contractor is required to obtain in connection with this project, shall be paid by the Contractor. The Contractor may include on each invoice the cost of the encroachment permit fee or any applicable paving restoration/moratorium fee for reimbursement. The Contractor shall not be reimbursed for any expenses above and beyond the actual cost of any permit such as travel time or administrative time. The Contractor shall comply with all requirements of all permits. Encroachment permits required for work in the public rights-of-way include but are not limited to the following:

- County of Contra Costa for work in Kensington, contact the Permit Engineer at the Department of Public Works, (925) 646-1607.
- City of El Cerrito for work in that jurisdiction, contact the City Engineer at (510) 215-4300.
- City of Richmond for work in the Richmond Annex, contact the Permit Department at (510) 620-6868.

4. PROJECT SIGNS: The District shall provide project identification signs to be posted by the contractor at prominent locations within the project area where the Contractor is currently working. All project identification signs shall be returned to the District at the end of the project.

5. PUBLIC NOTIFICATION. The Owner shall provide notice to affected homeowners of the impending construction activity.

At least forty-eight (48) hours prior to the start of work on any line segments located on private property the contractor’s representative and the Engineer or his delegate shall contact the individual homeowners to explain the construction activity, when it is to occur, where on the property the work is to occur, the materials and equipment to be used, and the obligation of the Contractor to protect, preserve and restore the property to its original condition

after construction. The homeowner will be presented with a business card and phone number of the Contractor and the Engineer or his delegate.

In easement areas, the Contractor shall provide special notice and arrangements with property owners whose property is to be used for pipe access or pulling pits.

Any area or private property accessed by the Contractor for his operations, shall first be videotaped with a station to station view all along the area of the easement and of any area where equipment, materials or workmen may traverse the private property. On completion of construction and surface restoration of easement and other areas disturbed by the Contractor's operations, the Contractor shall re-videotape the same areas of the property as originally taped for comparison pictures. Still photos shall also be taken along the same route of the video taping with copies to the homeowner and the District.

6. WORK WITHIN EASEMENTS: The right for the Contractor to enter within sewer easement areas will be granted by the District to the Contractor. Whenever the Contractor removes, cuts or otherwise opens an existing fence or gate in such manner that any domestic animals or livestock within the property then have access to the area of the Contractor's activities or to areas outside of the area formerly enclosed by the fence, the Contractor shall erect and maintain temporary fencing or gates to contain the domestic animals or livestock within the property until the Contractor has completed his activities and the original fencing or gates are repositioned.

7. PRESERVATION OF PROPERTY AND CLEANING: General Conditions, Section G4.12, Preservation and Cleaning. Each day and as directed by the Engineer or his delegate, the Contractor shall keep the project site and work areas clean and free of litter, rubbish, excess materials, false work, temporary structures, and equipment, not directly involved in the work.

All parts of the work shall be left in a neat and presentable condition at the completion of each workday. Barricades shall be placed around construction materials and equipment left on public rights-of-way. Loose backfill materials shall be removed from traveled areas.

The Contractor shall cleanup job site at the end of each workday, including covering of any open trenches. If cleanup is not satisfactory, the Engineer or his delegate will notify the Contractor who shall remedy the situation. If the Contractor fails to remedy the cleanup deficiencies immediately, the Owner, at its discretion, can arrange cleanup to be done by others at the Contractor's expense.

The Contractor shall be responsible for preserving all properties adjacent to or directly involved in the work.

Attention is directed to the following related sections of these Specifications:

General Conditions

- G5.13 Character of Workers
- G6.03 Storage of Materials
- G7.16 Public Convenience
- G7.17 Public Safety
- G7.18 Preservation of Property

Special Conditions

- All sections

Before final inspection of the work, the Contractor shall clean the project site, material sites, storage sites, and all other areas occupied by it and restore these sites or properties to their original condition. If requested by the District, the Contractor shall obtain written releases from private property owners stating they are satisfied with their property's restoration. Full compensation for cleanup and restoration will be considered as included in the prices paid for the various contract items of work and no separate payment will be made therefore.

8. STORAGE OF MATERIALS: Construction materials shall not be stored within the public right-of-ways

in such a manner as to impede the flow of public traffic nor create an unsafe condition, nor shall they be stored within fifteen (15) feet of a fire hydrant or in such a manner so as to impede access or visibility of any emergency facilities.

The Contractor shall be responsible for making whatever arrangements are necessary with private property owners to stockpile materials on private property if the Contractor desires storage outside of easements.

9. DEBRIS REMOVAL FROM PIPELINE CONSTRUCTION OPERATIONS: The Contractor shall provide adequate means to protect the sanitary sewer line from the entry of loose soil, rock, debris and broken bits of pipe disturbed during the repair, rehabilitation or reconnection work on the sanitary sewer lines.

The Contractor shall provide and install the mechanisms to trap all loose debris at the downstream manhole. On completion of the repair and/or reconnections on each line segment, the Contractor shall remove the accumulated debris, flush the upstream line segment with water; remove debris again, then remove the downstream trap. A detail of a successful trap installation is available at the District Office.

10. ARBITRATION: Any dispute arising out of this contract or the interpretation or performance thereof may be subject to arbitration under the Construction Industry Arbitration Rules of the American Arbitration Association by mutual agreement by both parties to the contract.

11. INSPECTION. General Conditions, Section G5.09, Inspection. Add the following paragraph to this section of the General Conditions:

“Whenever the Contractor works any overtime, whether weekend, holiday or more than eight (8) hours a day and, in the opinion of the Construction Manager, requires inspection by the Construction Manager, all premium pay in addition to regular pay shall be paid by the Contractor. The District shall bill the Contractor monthly for the total amount of premium pay incurred and shall deduct the amount billed from the Contractor’s monthly payments.”

12. WORK HOURS: Work hours shall be from 8:00am to 5:00pm, except in Cal-Trans right-of-ways, where work hours shall be from 9:00am to 3:00pm. Contractors shall not work on weekends or District holidays.

(This page left blank intentionally)

SECTION 2A

EXCAVATION, TRENCHING AND BACKFILLING

PART 1 - GENERAL

1. APPLICABLE PUBLICATIONS: The publications list below form a part of this specification to the extent referenced. The publications are referred to in the text by the basic designation only.

1.1 American Society for Testing and Materials (ASTM) Publications:

D 1557 Moisture-Density Relations of Soils and Soil-Aggregate Mixtures Using 10-lb. Hammer and 18-inch Drop

D 2487 Soils for Engineering Purposes, Classification

1.2 California Department of Transportation (CALTRANS):

TEST 216 - Relative Compaction of Untreated and Treated Soils and Aggregates

1.3 California Division of Industrial Safety (CALOSHA):

CONSTRUCTION - Title 8 California
SAFETY ORDERS - Administrative Code

2. DEFINITIONS:

2.1 Satisfactory Materials: Imported backfill conforming to the requirements of bedding and structural materials as specified on the plans.

2.2 Unsatisfactory Materials: Unsatisfactory materials shall be materials that do not comply with the requirements for satisfactory material. Unsatisfactory materials include, but are not limited to, those materials containing roots, and other organic matter, trash, debris, and stones larger than 3 inches, recycled Class 2 aggregate base, native material, and materials classified in ASTM D 2487 as PT, OH, and OL. Unsatisfactory materials also include "bay mud," man-made fills, or refuse.

2.3 Unyielding Material: Unyielding material shall consist of rock.

2.4 Unstable Material: Unstable material shall consist of materials too wet to properly support the utility pipe, conduit or appurtenant structure.

2.5 Bedding Material: Unless otherwise indicated, all pipes shall have a minimum of three (3) inches of bedding material below the barrel of the pipe. Bedding shall be placed and compacted as specified for initial trench backfill and shall be shaped around the barrel of the pipe. Bedding material shall be as designated on the Plans.

2.6 Subsequent Backfill: Select imported material as per trench section detail on plans.

2.7 Degree of Compaction: Degree of compaction shall be expressed as a percentage of the maximum density obtained by the test procedure presented in ASTM D 1557, method B or D.

3. SOILS REPORT: All excavations are being performed in existing trench backfill sections. No soils report was conducted for the work. No responsibility is assumed by the Owner for subsoil quality or conditions. It is the Contractor's responsibility to investigate the site soils conditions and to arrive at his own conclusions and

designs regarding excavation, trench stability and bracing, dewatering, safety and other construction aspects of the project.

4. TRENCH EXCAVATION SAFETY PLANS: Any excavation five (5) feet or more in depth shall not begin until the Contractor has submitted to the Engineer the Contractor's detailed plan for worker protection from the hazards of caving ground during the excavation of such trench. Such plan shall be submitted at least five (5) days before the Contractor intends to begin excavation for the trench and shall show the details of the design of shoring, bracing or other Conditions to be made for worker protection during such excavation. Sloping shall not be used under this contract due to limitations of right of way. No such plan shall allow the use of shoring or a protective system less effective than required by the Construction Safety Orders of the Division of Industrial Safety and if such plan varies from the shoring system standards established by the Construction Safety Orders, **the plan shall be prepared and signed by an Engineer who is registered as a Civil or Structural Engineer in the State of California.**

California Labor Code Section 6705 and all applicable Construction Safety Orders and shoring system standards with respect to excavation and construction shall be strictly observed at all times.

5. MAINTAINING TRAFFIC: Attention is directed to Sections G7.16 and G7.17 of the General Conditions. In connection with said sections, it is understood that all lights, signs, barricades, flagmen or other necessary devices shall be furnished and maintained by the Contractor at his own expense.

Construction operations shall be conducted in such a manner as to cause as little inconvenience as possible to abutting property owners; convenient access to any driveways, houses, buildings, public buildings and stores along the line of work shall be maintained. No driveway shall be closed for a period exceeding 6 hours unless such requirement is waived in writing by the Construction Manager.

Lane closures shall conform to the provisions set forth in the Manual of Traffic Controls of the State of California Department of Transportation.

The Contractor shall provide a detailed Traffic Control Plan, including schedule, for any portion of the work that requires closure of any part of a street to traffic. The Traffic Control Plan shall be submitted to the respective permitting authority for review and approval. Work shall not commence without an approved Traffic Control Plan in areas that require closure to any part of any street. After securing approval of the Traffic Control Plan, the Contractor shall notify the respective Police and Fire Departments.

Contractor shall provide a copy of the approved Traffic Control Plan for any work on affected bus routes to AC Transit, Attn.: Mr. Biff Williams, 1600 Franklin St., Oakland, CA 94612, (510) 891-4777, at least seventy-two (72) hours prior to work in said area.

The Contractor shall cooperate with all local authorities in maintaining traffic control. Local residents, as well as fire, school district, postal service, solid waste collectors and sheriff authorities, shall be notified at least twenty-four (24) hours in advance of any street closures as may be allowed by this special provision. Making arrangements for clearing of cars parked along the line of construction shall be the responsibility of the Contractor. Property owners shall be notified by the Contractor at least forty-eight (48) hours in advance of work adjacent to their property on a standard form prepared by the Contractor and approved by the Construction Manager. Should the Contractor appear to be neglectful in performing such notifications, the Engineer will cause such work to be performed and shall deduct the cost of carrying out this work from payments otherwise due the Contractor.

Whenever the Contractor's operations create a condition hazardous to traffic, or to the public, the Contractor shall take the necessary precautions and provide adequate means to protect those who must pass through or over the work. If the Contractor shall appear to be neglectful or negligent in providing such warning or protective measures, the Construction Manager may direct attention to the existence of a hazard, and require that necessary barricades, warning signs, lights or flagmen be installed by the Contractor; the entire cost of such protective measures will be considered as being included in the prices paid for the various items of work, and no additional allowance shall be made therefore. Any action by the Construction Manager as provided herein shall not relieve the Contractor from

responsibility for public safety.

The Contractor shall furnish flagmen for the purpose of expediting the passage of public traffic through the work under one-way controls. Full compensation for this work shall be considered as included in the unit price paid for all other items and no additional payment will be made therefore.

6. ARCHEOLOGICAL DISCOVERIES: General Conditions, Section G4.11, Archaeological Discoveries.

Add the following paragraphs to this section:

In accordance with the National Preservation Act of 1966, (16 U.S.C. 470) and PRM 75-27, the following procedures are implemented to insure historic preservation and fair compensation to the Contractor for delays attendant to cultural resources investigations.

In the event potential Historical, Architectural, Archeological, or Cultural Resources (herein after cultural resources) are discovered during subsurface excavations at the site of construction, the following procedures shall be instituted:

1. The Engineer shall issue a "Stop Work Order" directing the Contractor to cease all construction operations at the location of such potential cultural resources find.
2. Such "Stop Work Order" shall be effective until such time as a qualified archeologist can be called to assess the value of these potential cultural resources and make recommendations to the Owner. Any "Stop Work Order" shall contain the following:
 - a. A clear description of the work to be suspended;
 - b. Any instructions regarding issuance of further orders by the Contractor for material services;
 - c. Guidance as to action to be taken on subcontracts;
 - d. Any suggestions to the Contractor as to minimization of his costs;
 - e. Estimated duration of the temporary suspension.

If the archeologist determines that the potential find is a bona fide cultural resource, at the direction of the Owner, the Engineer shall extend the duration of the "Stop Work Order" in writing, and the Contractor shall suspend work at the location of the find.

Equitable adjustment of the construction contract shall be made in the following manner:

A. Time Extension. If the work temporarily suspended is on the "critical path", to total number of days for which the suspension is in effect shall be added to the number of allowable contract days.

If a portion of work at the time of such suspension is not on the 'critical path', but subsequently becomes work on the critical path, the allowable contract time will be computed from the date such work is classified as on the critical path.

B. Additional Compensation. If, as a result of a suspension of the work, the contractor sustains a loss which could not have been avoided by his judicious handling of forces, and equipment, or redirection of forces or equipment to perform other work on the contract, there shall be paid to the Contractor an amount as determined by the Engineer to be fair and reasonable compensation for the Contractor's actual loss in accordance with the following:

C. Idle Time of Equipment. Compensation for idle time of workers will be determined on a force account (time and materials) basis, and shall include the cost of extra moving of equipment and rental loss. The right-of-way delay factor for each classification of equipment shown in the California Department of Transportation publication entitled, "Equipment Rental Rates and the General Prevailing Wage Rates", will be applied to any equipment rental rates.

D. Idle Time of Labor. Compensation for idle time of workers will be determined by the Engineer as "Labor" less any actual productivity factor of this portion of the work force.

E. Increased Costs of Labor and Materials. Increased costs of labor and materials will be compensated only to the extent such increase was in fact caused by the suspension, as determined by the Engineer.

Compensation for actual loss due to idle time of either equipment or labor shall not include markup for profit.

The hours for which compensation will be paid will be the actual normal working time during which such delay conditions exists, but will in no case exceed eight (8) hours in any one day.

The days for which compensation shall be paid shall be full or partial calendar days, excluding Saturdays, Sundays, and legal holidays, during the existence of such delay.

PART 2 - EXECUTION

7. UTILITY CROSSINGS: It is anticipated that existing pipes, telephone lines, electric and gas lines, water mains, and service laterals may conflict with the planned sanitary sewer facilities. Prior to commencing work, the Contractor shall contact Underground Service Alert (USA) at 1-800-642-2444 to verify the location and depth of the existing utilities and service laterals.

The contract unit price paid per lineal foot of installed pipe shall include full compensation furnishing all labor, materials, tools, equipment and incidentals, any utility related progress delays, and for doing all the work necessary to cross underneath existing utilities and no additional compensation will be allowed therefore.

8. PAVEMENT CUTTING:

8.1 General: All trenches in paved areas, concrete areas or at other areas as determined by the Engineer, shall be cut to a depth of at least two (2) inches by any mechanical means which will produce a neat straight line on the edge of the existing pavement to remain. However, the use of pavement breakers or other pneumatic devices for cutting pavement will not be permitted. If, when determined by the Engineer, the method of cutting the pavement causes cracking of the pavement that is to remain in place, the method shall be discontinued. Cracked or broken pavement or concrete caused by the Contractor's operations shall be removed and replaced with new asphalt concrete or concrete all at the Contractor's expense. Contractor shall re-cut the pavement edge if the edge has deteriorated during construction.

Any such pavement to be removed shall be cut to a neat, trim line and replaced as directed by the Engineer.

8.2 Concrete: Where concrete is removed for installation of sewer pipe, existing concrete shall be saw cut or removed to the nearest joint and replaced with six (6) inches of concrete over four (4) inches of Aggregate Base.

8.3 Measurement and Payment: Pavement cutting of all types shall be included in the unit price bid and paid for the pipeline to be constructed under this contract. There will be no separate measurement or payment for pavement cutting.

9. TRENCH EXCAVATION: Trench excavation of every description, and of whatsoever substances encountered shall be performed to the lines and grades indicated.

There will be no classification of excavated material for payment purposes under this contract.

9.1 Stockpiling of Material: During the excavation, material satisfactory for backfilling shall be stockpiled in an orderly manner at a distance from the banks of the trench sufficient to avoid overloading and to prevent slides or cave-ins. Where traffic control, material quantities, limited room to work or other conditions will not allow stockpiling along the trench route, materials may be stockpiled at other locations off streets and roads. Adequate drainage shall be provided for the stockpiles and surrounding areas by means of ditches, dikes, or other approved means. The stockpiles shall be protected from contamination with unsatisfactory excavated material or other material that may destroy the quality and fitness of the suitable stockpiled material. If the Contractor fails to protect the stockpiles and any material become unsatisfactory as a result of such failure, the Contractor shall remove trench backfill and replace said unsatisfactory material with satisfactory on-site or imported material from approved sources.

9.2 Trench Safety: The Contractor shall furnish, place and maintain all sheet piling, shoring, bracing, lagging shields or other precautions as may be required to support the sides of the excavation, protect the workmen, facilitate the work, and prevent any injury to the work contemplated or to any other structure or work all in accordance with the Trench Excavation Safety Plan, with these specifications, and with the rules of CAL OSHA. The installation of such shoring and bracing as above specified shall be placed immediately after excavation of the trench in order that the requirements for minimum trench width are met.

9.2.1 Measurement: Trench safety shall be measured and paid as one lump sum per job. Mainline sewers, side sewers, and laterals will be included.

9.2.2 Payment: The contract lump sum priced paid for trench safety and protection shall include full compensation for furnishing all labor, material, tools, equipment and doing all the work involved in preparing detailed plans for trench excavation safety and obtaining the necessary permits, and for providing, constructing, installing, and maintaining the shoring and bracing as shown on the Trench Excavation Safety Plan and as directed by the Construction Manager and no additional compensation will be allowed therefore.

9.3 Minimum Cover: The profile of the existing ground as shown on the plans is considered sufficiently accurate to denote the general shape of the existing ground. It does not, however, show the existing ground with sufficient accuracy to be used for an "engineered pipeline". If a profile of this accuracy is required, the Contractor shall make provisions to obtain the required information. The Contractor shall maintain a minimum of three (3) feet of cover over the top of sewer pipes to be installed. In areas of less than minimum cover, the Contractor, as directed by the Engineer, shall lay pipe to a revised profile or encase in concrete or use ductile iron pipe (DIP).

9.4 Control of Line and Grade: All pipe shall be laid to conform to the prescribed line and grade as shown on the plans except as such adjustments are ordered by the Engineer to maintain minimum cover requirements. The grade line shall be established before any pipe is laid in the trench. Each pipe length shall be checked to ensure conformance to the grade line that the Contractor established from the grade stakes.

For pipes with slopes greater than two (2%) percent, the string line set for trenching purposes may be used as the grade line. For pipes with slopes less than two (2%) percent, either: (1) a grade line shall be established in the bottom of the trench such that the top of each bell will touch the line when the pipe has been properly positioned, or (2) a grade line shall be established above the trench on firmly secured batter boards from which the grade of each pipe can be checked by using a grade pole.

Alternate use of commercial LASER grade setting systems in lieu of string lines specified herein is acceptable when the following requirements and conditions are met:

9.4.1 The Contractor shall have the responsibility of providing an instrument operator who is qualified and trained in the operation of the LASER and said operator must adhere to the provisions of the State of California Construction Safety Orders issued by the Division of Industrial Safety. Attention is particularly directed to Sections 1516, and 1800 through 1801, of said Orders for applicable requirements.

9.4.2 All LASER control points shall be established benchmarks or construction offset stakes identified on cut sheets and set in the field for the work. LASER set up points shall be on these control points or on points set directly from them by instrument.

9.5 Trench Width: The maximum allowable width of trench measured six (6) inches above the top of the pipe, exclusive of bells and collars, is shown on the plans, except where trench bracing, shoring and timbers is required. A minimum of six (6) inches shall be maintained between pipe and trench wall. Where shoring is required, the trench width shall be increased only by the thickness of the sheathing.

Wherever the maximum allowable trench width designated on the plans is exceeded for any reason, the Contractor shall, at his expense, encase the pipe in concrete. Concrete encasement shall be monolithic reinforced concrete constructed to the details shown on the plans. Where trenches are over-excavated to remove large rocks or boulders and large voids occur below the bedding plane shown on the plans, and the over-excavation has not been ordered by the Engineer for stabilization of foundation material, the resulting void shall be backfilled with concrete to the limits shown on the plans, all at the Contractor's expense. Where over-excavation of a general nature occurs and large voids are not present below the bedding plane,

the over-excavation shall be backfilled with bedding material at the Contractor's expense. Concrete for encasement and backfill shall be as specified in Section 2D of these Technical Conditions.

9.6 Open Trench: During trenching operations, trenches shall not be excavated farther than 200 feet in advance of pipe laying operations or left in an unbackfilled condition more than 50 feet to the rear thereof unless so authorized by the Engineer. In no case shall a trench remain open overnight. Steel plating of open trenches overnight will be considered as full compliance with this specification. The Engineer may amend such requirements by written notice to the Contractor upon approval of the Contractor's plan for protecting the public safety from trenches left open overnight.

9.7 Temporary Resurfacing: Temporary trench surfacing composed of cutback asphalt shall be placed in all trenches in paved roadway areas at the end of each working day after completion of pipe laying operations in that section of trench. In lieu of temporary surfacing and at the Contractor's option, permanent surfacing may be placed in the trench if testing of the section of pipe has been completed and approved by the Engineer following pipe laying operations. Unpaved trenches in roadway areas shall be delineated for the public safety as specified in Section 7-1.09, "Public Safety," of the Standard Specifications. When pavement lane delineation is removed or obliterated by the Contractor's operations, the Contractor shall replace such delineation in kind as soon after completion of temporary trench resurfacing as, in the judgment of the Engineer, is practical.

9.8 Tree Roots: Major roots (four (4) inches or greater in diameter) encountered in the course of excavation shall be exposed but not severed, and they shall be wrapped in burlap as a protective measure while exposed. Roots (two (2) to four (4) inches in diameter) that are severed in the course of excavation shall be neatly trimmed and coated with a heavy coat of an approved tree seal.

9.9 Trench Dewatering: The Contractor shall take such measures as may be required and shall furnish, install, and operate such pumps or other devices as may be necessary to remove seepage, storm water or sewage that may be found or accumulate in the excavations during the progress of the work. Once seepage or ground water conditions in the trench are encountered, no further trenching will be allowed until suitable dewatering procedures are in operation. The Contractor shall keep all excavations free from water at all times during the construction of the work and until the Engineer gives permission to cease pumping. He shall keep his completed work free from accumulations of water and sewage and shall free it entirely at such times as may be required by the Engineer for inspection or other purposes.

9.10 Trenching in Rock: No blasting will be allowed for this project. When, in the judgment of the Engineer: (1) the excavatability of the subsurface material is such that it cannot be removed by conventional trenching equipment, (including excavator with rock ripping teeth), and (2) the Contractor has demonstrated to the satisfaction of the Engineer that the best available construction equipment cannot remove material from a trench to the specified depth, the Engineer may authorize in writing the use of jackhammers, hoe ram, non-explosive chemical expansion techniques, or such other method as determined by the Contractor.

10. EARTHWORK: Earthwork in connection with the construction of pipelines shall be a subsidiary part of the excavation and backfill for pipelines or structures and no separate measurement or payment will be made for Earthwork.

11. STRUCTURE EXCAVATION: Structure excavation shall conform to Section 19-3, "Structure Excavation and Backfill," of the Standard Specifications and these Technical Conditions.

12. BACKFILL:

12.1 Structural Backfill: Structural backfill shall conform to Section 19-3, "Structure Excavation and Backfill," of the Standard Specifications, these Technical Conditions and as shown on the plans:

The compaction requirements for structure backfill material shall be as shown on the plans and specified in

these Technical Conditions. Unless otherwise as shown for specific zones plans, structure backfill in public streets shall be compacted to a relative compaction of not less than 95 percent as obtained by the test procedure presented in ASTM D 1557, method B or D. Ponding and/or jetting of backfilling will not be allowed.

12.2 Pipeline Backfill: Trench backfill for pipelines shall conform to the following requirements unless otherwise directed by the Plans:

12.2.1 Granular Bedding: Granular bedding or slurry cement placed to the depths shown on drawing shall be compacted to relative density of 95 percent, unless stated otherwise on the plans.

12.2.2 Subsequent Backfill in Streets or Roads: Subsequent backfill for paved City and State roads, streets or lanes shall be select imported material, as per trench detail, compacted in lifts not exceeding eight (8) inches uncompacted thickness to 95 percent relative density.

12.2.3 Testing: Backfill shall be tested utilizing the test procedures specified in Section 19-1.01 of the Standard Specifications and at the intervals therein specified. Any backfill testing costs to the District for testing layers which fail the compaction requirements will be deducted from any progress payments due the Contractor when, in the opinion of the Engineer, such failure results from the Contractor's lack of diligence in pursuing compaction effort.

12.2.4 Temporary Resurfacing: The same day the trench is backfilled, it will be graded to conform to the existing surface, and for trenches in paved areas, within 48 hours a temporary pavement consisting of a minimum of two (2) inches of premixed asphalt paving material shall be placed over the trench. The Contractor shall maintain temporary pavement in a safe and drivable condition until permanent pavement is placed.

13. SURPLUS MATERIAL: The Contractor's attention is directed to the fact that there may be surplus excavated material on the project. Excess excavated material shall become the property of the Contractor and shall be disposed of outside the right of way in accordance with the conditions in Section 7-1.13, "Disposal of Material Outside the Highway Right of Way," of the Standard Specifications. Material from trench excavation that is to be utilized in trench backfill shall be stored in such a manner so as to not interfere with public use of the street right-of-ways, nor shall such storage extend onto private property without written authorization from the private property owner.

Excess materials shall be placed, compacted and graded in conformance with local regulations.

14. DUST CONTROL:

14.1. General: Dust control shall conform to the conditions of these Technical Conditions. The Contractor's attention is directed to the importance of dust control on this project. The Contractor shall provide dust control at all times including Saturdays, Sunday and holidays.

14.2. Application: The Contractor shall diligently control dust resulting from the Contractor's operations and from public traffic passing through the work by the application of water and/or dust palliative. Wherever the Contractor shall appear to be negligent in controlling dust, the Engineer may direct attention to the existence of a dust hazard and instruct the Contractor to alleviate said hazard. The Contractor shall immediately comply with the Engineer's instructions. Binder for dust palliative, when ordered by the Engineer shall conform to Section 18, "Dust Palliative," of the Standard Specifications.

14.3. Measurement and Payment: Payment for dust control shall be included in the unit price bid and paid for the individual items of work for which it is associated and no additional compensation will be allowed therefore, except that binder when ordered by the Engineer shall be paid for as Force Account work.

15. EXISTING FACILITIES: The work performed in connection with various existing facilities shall conform to the conditions in Section 8-1.10, "Utilities and Non-Highway Facilities," and in Section 15, "Existing Highway Facilities," of the Standard Specifications and these Technical Conditions.

It is anticipated that utilities not shown on the plans may exist within the right-of-way and may interfere with construction progress. In the event such utilities are discovered, the Engineer shall be immediately notified. Attention is directed to Section 8-1.10, "Utility and Non-Highway Facilities," of the Standard Specifications.

16. MEASUREMENT AND PAYMENT: All earthwork, excavation, trenching, and backfill, structural excavation and structural backfill, conditioning of materials and disposal of excess, shall be included in the unit price and paid for the individual items of work with which they are associated under the work to be performed under this contract.

(This page left blank intentionally)

SECTION 2B
SANITARY SEWERS

PART 1 – GENERAL

1. APPLICABLE PUBLICATIONS: The publications list below form a part of this specification to the extent referenced. The publications are referred to in the text by the basic designation only.

1.1 American Society for Testing and Materials (ASTM) Publications:

A 307 Carbon Steel Externally Threaded Standard Fasteners

C 425 Compression Joints for Vitrified Clay Pipe and Fittings

C 478 Precast Reinforced Concrete Manhole Sections

C 700 Vitrified Clay Pipe, Extra Strength (R 1983) Standard Strength and Perforated

D 1869 Rubber Rings for Asbestos-Cement Pipe

1.2 American National Standards Institute, Inc. (ANSI) Standards:

A21.10 Ductile-Iron and Gray-Iron Fittings, 3 inch, for Water and Other Liquids

A21.15 Flanged Ductile-Iron and Gray-Iron Pipe with Threaded Flanges

A21.50 Thickness Design of Ductile-Iron Pipe

A21.51 Ductile Iron Pipe, Centrifugally Cast in Metal Molds or San-Lined Molds, for Water and Other Liquids

B16.1 Cast Iron Pipe Flanges and Flanged Fittings, Class 25, 125, 250 and 800

1.3 American Water Works Association (AWWA):

C 104 Cement-Mortar Lining for Ductile-Iron and Gray-Iron Pipe and Fittings for Water

C 105 Polyethylene Encasement for Ductile-Iron Piping for Water and Other Liquids

C 110 Gray-Iron and Ductile-Iron Fittings, 3 inch through 48 inch, for Water and Other Liquids

C 111 Rubber Gasket Joints for Ductile-Iron and Gray-Iron Pressure Pipe and Fittings

1.4 Federal Specifications:

SS-S-00210 Type I, Rope Form

PART 2 – PRODUCTS

2. **GENERAL:** Gravity sanitary sewers shall be constructed in conformance with this section of the specifications. The construction required herein shall include appurtenant structures and lateral sewer reconnections. Backfilling shall be accomplished after inspection by the Engineer. Sewer pipe and sewer structures shall conform to the Standard Specifications and these Technical Conditions.

2.1 Allowable Pipeline Material: At locations where the plans indicate Vitrified Clay Pipe (VCP), pipeline material may be Vitrified Clay Pipe, Ductile Iron Pipe, or equal pipe material. High-Density Polyethylene (HDPE) pipe shall be used where the plans indicate for pipe bursting or pipe sliplining as specified in Section 2E of these Technical Conditions. Uniform pipeline material shall be used between adjacent manholes unless otherwise directed by the plans.

2.2 Vitrified Clay Pipe (VCP):

2.2.1 Governing Standards: Vitrified Clay Pipe shall conform to requirements of ASTM C 700 and C 425 for extra strength pipe with flexible compression joints. At the option of the Contractor, clay sewer shall conform either to the absorption requirements of AASHTO Designation M 65 or to the permeability requirements as specified and as determined by California Test 672.

2.2.2 Materials:

Pipe and Fittings ASTM C 700, extra strength.
Ordinary Joints ASTM C 425.

2.2.3 Testing: Control test shall be made during the manufacture of the pipe to determine crushing strength, absorption, and acid resistance, in accordance with ASTM C 301 and ASTM C 700. Affidavit of compliance, certifying that pipe, fittings and jointing materials are in compliance with the governing standards shall be submitted to the Engineer.

2.3 Ductile Iron Pipe (DIP):

2.3.1 Materials:

Pipe: Ductile Iron, ANSI/AWWA C 151/A21.51 ANSI Thickness Class 50

Push-on Joints: ANSI/AWWA C 111/A21.11, except gaskets shall be neoprene or other synthetic rubber. Natural rubber will not be acceptable.

Shop Coating and Lining:

Asphaltic Coating: Manufacturer's standard.

Polyethylene Tube: Seamless, ANSI/AWWA C 105/A21.5.

2.3.2 Shop Coating and Lining: The interior of all pipe shall be lined with coal tar epoxy coating to a thickness of 25 mils. Exterior surfaces of all pipe shall be asphaltic coated.

Application of the coal tar epoxy shall be in accordance with the manufacturer's recommendations and shall meet AWWA C 210-84 requirements. The coal tar epoxy shall be bitumastic self priming, chemically cured and catalyzed coal tar epoxy and shall be applied in more than one application on the interior of the pipe to achieve the required specified thickness.

2.3.3 Cutting Pipe: Cutting shall be done in a neat manner, without damage to the pipe or the lining. Cuts shall be smooth, straight, and at right angles to the pipe axis. After cutting, the end of

the pipe shall be dressed with a file or power grinder to remove all roughness and sharp edges. The cut ends of push-on pipe shall be suitably beveled.

End of ductile iron pipe shall be cut with a portable guillotine saw, abrasive wheel, saw, milling cutter, or oxyacetylene torch. The use of hydraulic squeeze type cutters will not be permitted.

2.3.4 Polyethylene Tube Protection: Ductile iron pipe shall be provided with polyethylene tube protection installed in accordance with AWWA C 105, Method A.

2.4 High-Density Polyethylene (HDPE) pipe:

2.4.1 Pipe And Fitting: Polyethylene pipe and fittings shall be Plexco EHMW PE 3408 SDR 17 or SDR21, gray in color, or approved equal, consisting of virgin high molecular weight polyethylene, specified under ASTM D3350 as having a cell classification of PE345434C. Manhole adapter rings shall conform to recommendations of manufacturer of PE pipe supplied.

2.4.2 Pipe Joint: Pipe shall be butt welded in accordance with ASTM D2657-67. The joints shall be leak proof, thermal, butt joints. All fusing shall be done using tools recommended by the pipe supplier and approved by the District. Operators shall be certified by the pipe manufacturer. The fusing machine shall have hydraulic pressure control for fusing two pipe ends together. The ends of pipe shall be trimmed to form perpendicular faces prior to fusing. The heating plate on the fusing machine shall be electrically heated and thermostatically controlled and shall contain a temperature gauge for monitoring temperature. The heating plate shall be subject to periodic inspection, using a temperature stick, to assure even heating.

The tensile strength of yield of the butt fusion joints shall not be less than that of the pipe. A specimen of pipe cut across the butt fusion joints shall be tested in accordance with ASTM C638.

Any material may be rejected for failure to meet any of the requirements of this specification. The acceptance of any deviation from these specifications shall be subject to the approval of the District.

The internal bead shall be controlled to protrude no greater than 1/8 inch circumferentially on the inside wall of the pipe barrel. .

2.5 Sewer Manhole: New sewer manholes, drop sewer manholes and junction boxes shall conform to the Standard Specifications and these Technical Conditions. All manhole precast sections shall conform to ASTM C 478 where not otherwise modified in the details of the plans. Manholes shall be water-tight structures. Base for new manhole shall be poured with Class A concrete against a base which is firm and dry. The design, the specifications, and the name of the manufacturer shall be submitted to the Engineer for approval prior to the purchase of any precast manhole units. Brick manholes will not be allowed.

2.6 Concrete: Concrete shall conform to the requirements of SECTION 2D: CONCRETE of these Technical Conditions.

2.7 Polyethylene manhole: Polyethylene manhole cone and barrel sections shall be manufactured by Rhino USA of Oregon LLC or approved equal meeting the following specification:

2.7.1. Standards

ASTM D-833	Definition of terms relating to plastics
ASTM D-3350	Specification for PE plastics molding and extrusions materials
ASTM D-2122	Determining dimensions of thermo plastic pipe and fittings
ASTM F-412	Definition of terms relating to plastic pipe systems
ASTM D-2412	External loading properties of plastic pipe by parallel plate loading
ASTM F-477	Electrometric seals (gaskets) for joining plastic pipe

2.7.2. Materials Manholes shall be produced using polyethylene compounds conforming to the requirement of TYPE III , Category “3” Class B, having a cell classification of 3354433E or higher and color/ultraviolet stabilizer as defined and described in ASTM D-3350. Reworked or reprocessed material shall not be allowed.

2.7.3. Manufacture Manholes shall be produced by the rotational molding process. Interior access shall be provided with non-metallic, factory molded steps. Segmented joints shall be bell-and-spigot with U-shaped gasket conforming to ASTM F-477. Anchor rings shall be at each joint and extend 2.5 inches from manhole outside diameter (O.D.). Stiffener rings shall be equal to or less than 24 inches apart, longitudinally and circumferentially around the barrel.

2.7.4. Requirements Manhole walls shall be 0.5 inches thick and homogenous throughout. Interior and exterior surfaces shall be free of foreign inclusions and surface defects

2.8 Pre-formed Manhole Gaskets: Pre-formed plastic sealing gaskets shall conform to the requirements of FEDERAL SPECIFICATION SS-SS-0021.

2.9 Manhole Adapter Rings: Manhole adapter rings shall conform to recommendations of manufacturer of pipe supplied.

2.10 Manhole Rehabilitation: The materials used shall be designed, manufactured, and intended for sewer manhole rehabilitation and the specific application in which they are used. The materials shall have a proven history of performance in sewer manhole rehabilitation. The materials shall be delivered to the job site in original unopened packages and clearly labeled with the manufacturer’s identification and printed instructions. All material shall be stored and handled in accordance with recommendations of the manufacturer and the American Concrete Institute. Recommended manufacturers shall include Mainstay Composite Liner by Madewell Products Corporation or approved equal. **Provide submittal to engineer for review.** Materials used for specific applications shall be as follows:

2.10.1. Manhole Patching and Repair: Visually inspect, restore and prepare existing manhole for rehabilitation per manufacturer recommendations. Loose debris shall be removed and large cracks and voids shall be cleaned and filled with high strength grout, mortar or similar patching compound. Loose brick from brick manholes shall be carefully restored and stabilized before performing any manhole rehabilitation. Exposed reinforcing steel shall be protected using Madewell 1312P epoxy putty or equal.

2.10.2. Manhole Restoration Mortar: Apply Mainstay ML-72, or approved equal, at a minimum thickness of **1”** or more, as per manufacturer’s recommendations.

2.10.3. Epoxy Coating: Apply Mainstay DS-5, or approved equal, at a minimum thickness of **100 mils** or more, as per manufacturer’s recommendations.

2.10.4. Manhole Frame Seal: Apply Madewell 806, or approved equal, at a minimum thickness of 1/4” or more, as per manufacturer’s recommendations to manhole, grade rings, and frame.

2.10.5. Others: Perform all recommended activities specified by the manufacturer as explained in the Restoration and Corrosion Barrier Composite Liner (Mainstay Composite Liner, or equal) specification.

PART 3 - EXECUTION

3. PIPE INSTALLATION: Gravity sanitary sewers shall be constructed in conformance with this section of the specifications. The construction required herein shall include appurtenant structures and lateral sewer reconnections. Sewer pipe and sewer structures shall conform to the Standard Specifications and of these Technical and Special Conditions.

3.1 Excavation: Excavation shall be in accordance with the applicable provisions of Section 2A: EXCAVATION, TRENCHING AND BACKFILLING of these Technical Provisions except as modified herein:

3.1.1 Minimum Cover: The profile of the existing ground as shown on the plans is considered sufficiently accurate to denote the general shape of the existing ground. It does not, however, show the existing ground with sufficient accuracy to be used for an “engineered pipeline”. If a profile of this accuracy is required, the Contractor shall make provisions to obtain the required information. The Contractor shall maintain a minimum of three (3) feet of cover over the top of sewer pipes to be installed. In areas of less than minimum cover, the Contractor, as directed by the Construction Manager, shall lay pipe to a revised profile or encase in concrete or use ductile iron pipe (DIP).

3.1.2 Control of Line and Grade: All pipe shall be laid to conform to the prescribed line and grade as shown on the plans except as such adjustments are ordered by the Engineer to maintain minimum cover requirements. The grade line shall be established before any pipe is laid in the trench.

3.1.3 Open Trench: During trenching operations, trenches shall not be excavated farther than 200 feet in advance of pipe laying operations or left in an unbackfilled condition more than 50 feet to the rear thereof unless so authorized by the Construction Manger. In no case shall a trench remain open overnight. Steel plating of open trenches overnight will be considered as full compliance with this specification. The Construction Manger may amend such requirements by written notice to the Contractor upon approval of the Contractor’s plan for protecting the public safety from trenches left open overnight.

3.1.4 Temporary Resurfacing: Temporary trench surfacing composed of cutback asphalt shall be placed in all trenches in paved roadway areas at the end of each working day after completion of pipe laying operations in that section of trench. In lieu of temporary surfacing and at the Contractor’s option, permanent surfacing may be placed in the trench if testing of the section of pipe has been completed and approved by the Construction Manager following pipe laying operations. Unpaved trenches in roadway areas shall be delineated for the public safety as specified in Section 7-1.09, “Public Safety,” of the Standard Specifications. When, pavement lane delineation is removed or obliterated by the Contractor’s operations, the Contractor shall replace such delineation in kind as soon after completion of temporary trench resurfacing as, in the judgment of the Construction Manager, is practical.

3.2 Sewer Mains: All main sewer pipe installations shall be accomplished as specified herein.

3.2.1 Transitions Between Pipe Materials: All pipe, pipe joints incorporated into the pipe, and manufactured fittings connecting pipe between structures shall be of the same type, quality, class and size unless otherwise specified or detailed on the plans. Transitions from pipe dissimilar in size and/or material shall be accomplished only at manholes except where directed by the Engineer, and then only by using special adapters, couplings, or expansion blocks approved by the Engineer for such use. All field cut pipe shall be accomplished with equipment recommended by the pipe manufacturer. No hammer and chisel cuts will be permitted.

3.2.2 Clearance to Obstructions: All sewer pipe shall be laid with a minimum of six (6) inches clearance from all other improvements and utilities, unless otherwise directed by the plans or approved by the Engineer.

3.2.3 Control of Line and Grade: All pipe shall be laid to conform to the prescribed line and grade as shown on the plans except as such adjustments are ordered by the Construction Manager to maintain minimum cover requirements. Each pipe length shall be checked to ensure conformance to the grade line which the Contractor establishes from the grade stakes.

For pipes with slopes greater than two (2%) percent, the string line set for trenching purposes may be used as the grade line. For pipes with slopes less than two (2%) percent, either: (1) a grade line shall be established in the bottom of the trench such that the top of each bell will touch the line when the pipe has been properly positioned, or (2) a grade line shall be established above the trench on firmly secured batter boards from which the grade of each pipe can be checked by using a grade pole.

Alternate use of commercial LASER grade setting systems in lieu of string lines specified herein are acceptable when the following requirements and conditions are met:

3.2.3.1 The Contractor shall have the responsibility of providing an instrument operator who is qualified and trained in the operation of the LASER and said operator must adhere to the provisions of the State of California Construction Safety Orders issued by the Division of Industrial Safety. Attention is particularly directed to Sections 1516, and 1800 through 1801 of said Orders for applicable requirements.

3.2.3.2 All LASER control points shall be established bench marks or construction off-set stakes identified on cut sheets and set in the field for the work LASER setup points shall be on these control points or on points set directly from them by instrument.

3.2.4 General Pipe Laying Techniques:

3.2.4.1 Gravity Sewers - Rigid Pipeline Material: Each length of pipe shall be laid on compacted, approved bedding material as specified and as shown on the plans and shall have full bearing for its entire length between bell holes excavated in said bedding material to allow for unobstructed assembly of all bell and spigot joints.

A sewer line, unless otherwise approved by the Engineer, shall be laid, without break, upgrade from point of connection to existing sewer and with the bell end forward or upgrade. Pipe shall not be laid when the Engineer determines that the condition of the trench or the weather is unsuitable. When pipe laying is not in progress, the upgrade end of the pipe shall be kept effectively closed with an approved temporary plug or cap.

3.2.5 Adjustments to Line and Grade: Adjustments of pipe to line and grade shall be made by scraping away or filling in and tamping approved material under the body of the pipe. No wedging or blocking to support the pipe will be permitted.

3.2.6 Capping and Plugging: Sewer pipes, branches, stubs, or other open ends which are not to be immediately connected, shall be plugged or capped with a standard watertight plug or cap, as approved by the Engineer for use in the particular installation. The plug or cap shall be placed on a standard manufactured end. Open pipe ends on which flushing inlets, etc., are to be constructed, shall be plugged with an approved mechanical expanding plug at all times until the structure is completed and the cover is in place.

3.2.7 Bypassing Sewage During Construction: All work under the contract shall be done without interruption of service, except when approved the District. Such interruption of service

shall be only for as long as a period as is reasonably required, and shall be carefully scheduled with operating personnel.

The Contractor shall be responsible for maintaining all flows within the system. The Contractor shall bypass the flows around those sections of pipe to be replaced. Certain individual services and laterals within the project areas may also require bypassing during the pipe bursting operations as determined by the District.

The bypass shall be made by plugging an existing upstream manhole if necessary and pumping the sewage into a downstream manhole or adjacent system. The pump and bypass lines shall be of adequate capacity and size to handle the flow. Contractor shall submit written list of equipment and materials and method proposed to be used for bypassing to District shall in no way be construed as relieving the Contractor of any responsibility under this contract as related to protection of the interests of the District and the general public.

At the end of each working day, a temporary tie-in shall be made between the replaced section by pipe bursting, service connection, and the existing system. The bypass plug will either be removed or the pumps will be manned on a 24-hour basis.

Under no circumstances shall the discharge of raw sewage to other than an approved sanitary sewer be allowed. Bypassing of untreated or partially treated wastewater to surface waters or drainage courses is a violation against the law and will result in assessment of damages.

3.2.8 Bedding: Bedding shall conform to gradation and requirements described in the Plans.

3.2.9 Backfill: Backfill shall be in accordance with the applicable provisions of Section 2A: EXCAVATION, TRENCHING AND BACKFILLING.

3.2.10 Measurement and Payment:

3.2.10.1 Measurement - Pipe Length: Sewer pipe shall be measured as specified herein. The lengths of the sewer pipe to be paid for by the lineal foot shall be the horizontal length designated by the Engineer. The length shall be measured from center of manhole to center of manhole and through casings. No deductions will be made from horizontal length for manholes or lateral fittings.

3.2.10.2 Payment: Items of work, measured as provided above will be paid for at the contract prices per linear foot for the various sizes and types of sewer pipe. The prices paid per linear foot for the various sizes and type of sewer pipe shall be considered full compensation for all pipe, structure excavation, structure backfill, all trench dewatering, and for all temporary resurfacing of trench and all other incidentals required to construct all pipe systems complete in place and no further compensation will be allowed therefore. No measurement will be made or included for surplus pipe (wastage) remaining because of Contractors need to cut standard lengths to fit field conditions.

3.3 Sewer Main Point Repairs Independent of Pipe Replacement: There are instances wherein an isolated sewer main pipe needs to be repaired independent of complete sewer main replacement. Where only a short section of pipe is damaged in a reach of sound pipe in good condition as indicated by the Engineer, a point repair shall be made to realign the pipe. For purposes of measurement and payment, a point repair shall consist of a 15 foot long trench excavation, sheeting and shoring, 8 feet of sewer line replacement, pipe bedding, and backfilling. Payment for point repairs shall be at the unit price for point repairs listed in the bid proposal. **It is assumed that sanitary sewer mains in need of this nature of repair will occur independent of any mainline replacement. The Contractor is therefore required to include any mobilization costs as part of this bid line item.**

3.3.1 Requirements: All repair work shall conform to the installation of new sanitary sewer main as per this section.

3.3.2 Payment: Payment will be made at the unit price bid each to **include mobilization and to perform all repair work independent of any sanitary sewer main line replacement work.** Items of work, measured as provided above will be paid for at the contract prices for each repair at the noted standard measurements for the various sizes and types of sewer pipe. The prices paid per spot repair for the various sizes and type of sewer pipe shall be considered full compensation for all pipe, structure excavation, structure backfill, all trench dewatering, and for all temporary resurfacing of trench and all other incidentals required to construct all pipe systems complete in place and no further compensation will be allowed therefore. No measurement will be made or included for surplus pipe (wastage) remaining because of Contractors need to cut standard lengths to fit field conditions. No separate mobilization costs may be included in this bid item.

4. MANHOLES: Standard, trunk and drop sewer manholes shall be constructed at the locations shown on the plans and in accordance with the details shown on the drawings and with these Technical Conditions.

4.1 Excavation: Manholes shall be excavated in conformance with the requirements of Section 19-3 of the Standard Specifications except as modified herein. Temporary plugs, plates, or covers shall be installed whenever manholes are left in an incomplete state overnight.

4.2 Manhole Bases: Concrete manhole bases shall be constructed to the dimensions and details shown on the plans. Manhole bases for precast manholes shall be poured against native, undisturbed material, which has been excavated to the dimensions shown on the plans. If the Contractor over-excavates beyond the horizontal dimensions shown on the detail drawings, he shall construct forms and pour the base to the specified dimensions, or alternatively, pour the base neat against undisturbed soil. Any excess concrete required because of over-excavation shall be at the Contractor's expense. No precast manhole bases will be allowed.

An approved metal forming ring shall be used to form a level joint groove in fresh concrete of a manhole base; to receive the first precast barrel section of the manhole. The metal forming ring may be removed as soon as the concrete has set sufficiently to eliminate any slump in the joint groove.

Wherever possible, the sewer pipe shall be carried continuously through the location for the manhole, then the manhole shall be constructed and the open channel then formed by splitting the pipe and removing the top half. When it is not possible to carry the pipe continuously through the manhole, the open channel shall be formed of concrete and shall be of the same diameter as the inside of the sewer pipe, segmental in shape, and of a depth equal to one half (1/2) the diameter of the sewer pipe. The floor of each manhole shall have a minimum slope of two (2) inches/foot from the sides toward the open channel. Where sewers enter at elevations above the main sewer manhole base, channels or drops shall be constructed. Pipe shall be used as a form for the channel. After the manhole base concrete has taken a set, the channel shall be carefully shaped and mortared to obtain a smooth channel. All channels shall be checked with the proper template.

Special approval must be obtained from the Engineer prior to any work on a manhole to be constructed in an existing street or other area, which requires that the manhole barrel be set directly into the freshly poured manhole base in order that the manhole may be backfilled the same day that it is excavated.

4.3 Installation: All joint surfaces of precast sections and face of manhole base shall be thoroughly clean prior to setting precast sections. These various sections shall be set in pre-formed plastic sealing gaskets. Care shall be taken to properly align the manhole section with the previously set section before it is lowered into position.

4.3.1 Installation of Gaskets:

4.3.1.1 During cold or wet weather, pass direct heat over the concrete joint surface lightly until ice, frost and moisture are removed and surface to be primed is dry and warm immediately before application of primer. Direct heat shall also be passed over plastic gasket strips immediately prior to attaching them to joint surfaces and immediately prior to insertion of tongue into groove.

4.3.1.2 Apply one coat of primer to clean, dry joint surface (both tongue and groove) and allow to dry. Remove the paper wrapper from one side only of the two-piece wrapper on the gasket. The outside paper will protect the gasket and assure against stretching. Before setting the manhole section in the trench, attach the plastic gasket strips end-to-end to the tongue or groove of each joint, forming a continuous gasket around the entire circumference of the manhole joint.

4.3.1.3 Handling of barrel sections after the plastic gasket has been affixed shall be carefully controlled to avoid bumping the gasket and thus displacing it or covering it with dirt or other foreign material. Any gaskets so disturbed shall be removed and replaced if damaged and repositioned if displaced.

4.4 Manhole Throat: The maximum depth of the manhole throat shall be twelve (12) inches, measured from the top of the manhole cover to the lower extremity of the throat at the top of the cone section.

The throat shall be constructed by use of appropriately sized reinforced concrete grade rings that will bring the manhole cover to finished grade surface. No plastic sealing gaskets shall be used for jointing grade or extension rings in place.

4.5 Manhole Waterproofing and Lining: Outside surface of manhole wall must be thoroughly cleaned prior to the application of the waterproof and liner materials. The surface shall be free of oil, grease, wax and dirt.

The waterproof coating shall be applied over the entire wall of manholes in conformance with the manufacturer's instructions at a thickness of no less than 1/16 inch. A minimum of two coats of the waterproof material is required; however, an additional coat may be required, depending on the depth of the manhole. When completed, the waterproof coating shall be free of all cracks and/or holes and shall be able to withstand a hydrostatic pressure of seven (7) psi without any visible leaks.

Manhole waterproof coating shall be acrylic modified cementitious hydraulic waterproof coating for block and brick manholes, self curing, suitable for brush application, such as BRUSH BOND as manufactured by PERCO Industries Ltd., or TEGRAPROOF CONCENTRATE as produced by Tremcrete Systems, Inc., or equal.

4.6 Polyethylene Manhole Cone and Barrel Sections. Polyethylene manhole cone and barrel sections may be substituted for precast concrete cone and barrel sections as directed by the Engineer for specific use in designated locations. Materials, manufacture and requirements for these manholes shall be in accordance with all applicable provisions of the Technical Conditions of these specifications for standard main manholes and conform to the Standard Specifications.

4.7 Backfill: All precast manholes shall be backfilled in conformance with the requirements of Section 19-3 of the Standard Specifications. All backfill under, around and at least three (3) inches over all pipelines located with five (5) feet of structure bases shall be compacted prior to barrel section placements. All precast manholes shall be constructed to subgrade prior to compacting adjoining sewer pipeline trench and/or structure backfill. All precast manholes shall be backfilled with structural backfill. Structural backfill shall be in accordance with the details shown on the plans.

4.8 Manhole Frame and Collar: Manhole collars for precast manholes are intended to be poured

against native, undisturbed earth or compacted structure backfill material, which has been excavated to the dimensions shown on the drawings. If the Contractor over-excavates beyond or otherwise cannot maintain the horizontal or vertical dimensions shown on the plans, he shall construct forms to the specified dimensions prior to placement of concrete for the collar.

When completed, the top of the manhole cover shall be accurately brought to the elevation called for on the plans, or if no elevation is specified, shall be brought flush with the surface of the surrounding ground or pavement, or to the height above grade shown on the plans for manholes in easement areas and ditches, or as directed by the Engineer.

4.9 Measurement:

4.9.1 Measurement - Standard Manholes: Standard manholes will be measured as standard manholes or drop manholes.

4.9.2 Measurement - Trunk Manholes: Trunk manholes will be measured as trunk manholes.

4.10 Payment - Manholes and Appurtenances: The contract price per each for concrete sewer manholes and concrete drop sewer manholes and the contract unit prices paid per each for concrete trunk sewer manholes shall include full compensation for all saw cutting, complete removal of existing manholes where required, plugging pipes to be abandoned, structure excavation, structure backfill, bar reinforcing steel and concrete, miscellaneous iron and steel (including all frames and covers, manhole steps), bypassing of sewage flow, connecting pipes entering and leaving manhole, channeling of flows at bottom of manhole, disposal of removed materials offsite, all pavement replacement and all other labor, materials, tools, equipment, and incidentals required to complete sewer structures complete in place and no additional compensation will be allowed therefore.

5. MANHOLE REHABILITATION: Rehabilitation of the existing manholes shall include cleaning, sealing, plugging, patching, and coating of the manhole structure, including manhole chimney, corbel/cone, wall, and base with mortars, coatings and sealant.

5.1. Requirements: Contractor shall comply with all relevant provisions of the Safety and Health Regulations for Construction, promulgated by the Secretary of Labor, as set forth in Title 29 C.F.R., and with all provisions of the California Occupational Safety and Health Act of 1973.

Specific attention is directed to OSHA safety rules, regulations and precautions to be taken by the Contractor before entering sanitary sewer manholes, and other sanitation structures with respect to physical and chemical hazards that may be present inside sanitary manholes.

Crack openings on inside of existing manholes shall be sealed by first chipping out a minimum depth and width of 3/4 inch, mix and knead manhole patching compound then force compound into prepared crack. Contractor shall trowel inside surface to conform.

Any loose bricks or pieces of brick, mortar or concrete shall be removed and all voids and joints be filled with mixed kneaded manhole patching compound.

Contractor shall observe standard ACI procedures for storing, mixing and placing concrete for application of manhole patching compound and follow standard concrete curing procedures.

Perform manhole rehabilitation per manufacturers spec as outlined in Section 2.10, rehabilitation work shall be applied to all surfaces, from and including the manhole bench to the bottom of the frame. The material shall be applied to surfaces that are free of cracks or voids wider than 1/16 inch.

5.2. Payment: Manhole rehabilitation shall be measured as the number of manholes rehabilitated. The contract unit price bid for rehabilitating each sanitary sewer manhole shall include all labor, materials, tools

and equipment for cleaning, sealing, plugging, patching, and coating of the manhole structure, including manhole chimney, corbel/cone wall, and base with mortars, coatings and sealant.

6. MANHOLE ABANDONMENT: The existing sanitary sewer manhole and pipe to be abandoned in place shall be done in accordance with the details shown on the plans and the following requirements

6.1 Requirements: All manholes on abandoned sewers shall be abandoned, unless specified otherwise. For manholes to be abandoned, the Contractor shall break holes in the lower portions of the manhole wall and in the manhole base for proper subsurface drainage and remove the upper manhole cone or upper three (3) feet of the manhole including collar and frame and then fill with bedding material compacted to 90 percent relative compaction. The upper three (3) feet shall be backfilled with structural backfill compacted to 95 percent relative compaction. The Contractor shall restore road sections in kind or as per standard trench detail.

Frame and cover shall be removed from manholes to be abandoned, and frame and cover in good condition shall be salvaged and delivered by the Contractor to the District's maintenance yard at 7500 Schmidt Lane, El Cerrito. All other removed materials shall be disposed of offsite by the Contractor in accordance with applicable regulations. All pipes entering or leaving the abandoned manhole shall be plugged with a minimum of twelve (12) inch concrete.

6.2 Payment: Payment will be made at the unit price bid each to include full compensation for the removal of the cone or top section, breaking up the lower portion of wall for drainage, plugging pipes to be abandoned, backfilling with structural backfill material, surface restoration, salvage and delivery of manhole's frame and cover by Contractor to the District's maintenance yard, and disposal of all removed materials offsite.

7. MANHOLE REMOVAL: The removal of existing sanitary sewer manhole shall be in accordance with the details shown on the plans and the following requirements:

7.1 Requirements: Sanitary sewer manholes to be removed at locations as shown on the plans shall be removed completely, including manhole base, wall, cone, collar, frame and cover. Frame and cover in good condition shall be salvaged and delivered by the Contractor to the District's maintenance yard at 7500 Schmidt Lane, El Cerrito. All other removed materials shall be disposed of offsite by the Contractor in accordance with applicable regulations.

7.2 Payment: Payment will be made at the unit price bid each to include full compensation for the complete removal of existing manholes and backfill with structural material, salvage and delivery of manhole's frame and cover by Contractor to the District's maintenance yard, and disposal of all removed materials offsite.

8. MANHOLE FRAME REPAIR: There are instances where an existing sanitary sewer manhole may be of sound condition with the possible exception of inflow and infiltration caused by a cracked concrete surface, damaged collar (labeled as 'top block' in the details) or concrete cone. **It is assumed that sanitary sewer manholes in need of this nature of repair will occur independent of any mainline repair, and it is also assumed that these sanitary sewer manholes will be located in concrete paved areas such as sidewalks, pathways, driveways, concrete stairways and paved easements with private property. The Contractor is therefore required to include any mobilization costs as part of this bid line item.**

8.1. Requirements: Sanitary sewer manhole collars, frames and covers to be repaired and replaced at locations as shown on the plans shall be removed completely. Frame and cover in good condition shall be salvaged and delivered by the Contractor to the District's maintenance yard at 7500 Schmidt Lane, El Cerrito. All other removed materials shall be disposed of offsite by the Contractor in accordance with applicable regulations. In addition any large voids or cracks located inside the concentric cone shall be patched and sealed with appropriate mortar and grout to prevent inflow and infiltration. Frame and covers shall be adjusted to proper flush grade with existing

conditions. All repair work shall conform to the appropriate subsections of the installation of new manholes as per this section.

- 8.2. Payment: Payment will be made at the unit price bid each to **include mobilization and to perform all repair work independent of any main line work**, the full compensation of complete removal of existing manhole collar, frame and cover, salvage and delivery of manhole's frame and cover by Contractor to the District's maintenance yard, and disposal of all removed materials offsite. In addition, unit prices paid per each sewer manhole repair shall include full compensation for all saw cutting, structure excavation, structure backfill, bar reinforcing steel and concrete, miscellaneous iron and steel (including all frames and covers), bypassing of sewage flow, all pavement replacement and all other labor, materials, tools, equipment, and incidentals required to complete sewer structures complete in place and no additional compensation will be allowed therefore. No separate mobilization costs may be included in this bid item.

9. JUNCTION BOXES: Junction boxes shall be constructed at the locations shown on the plans and in accordance with the details shown on the drawings and with these Technical Conditions.

- 9.1 Excavation: Junction boxes shall be excavated in conformance with the requirements of Section 19-3 of the Standard Specifications except as modified herein. Temporary plugs, plates, or covers shall be installed whenever junction boxes are left in an incomplete state overnight.

9.2 Junction Box Bases: Concrete junction box bases shall be constructed to the dimensions and details shown on the plans. Junction box bases shall be poured against native, undisturbed material, which has been excavated to the dimensions shown on the plans. If the Contractor over-excavates beyond the horizontal dimensions shown on the detail drawings, he shall construct forms and pour the base to the specified dimensions, or alternatively, pour the base neat against undisturbed soil. Any excess concrete required because of over-excavation shall be at the Contractor's expense. No precast junction box bases will be allowed.

Wherever possible, the sewer pipe shall be carried continuously through the location for the junction box, then the junction box shall be constructed and the open channel then formed by splitting the pipe and removing the top half. When it is not possible to carry the pipe continuously through the junction box, the open channel shall be formed of concrete and shall be of the same diameter as the inside of the sewer pipe, segmental in shape, and of a depth equal to one half (1/2) the diameter of the sewer pipe. The floor of each junction box shall have a minimum slope of two (2) inches/foot from the sides toward the open channel. Where side sewers enter at elevations above the main sewer junction box base, channels shall be constructed. Pipe shall be used as a form for the channel. After the junction box concrete has taken a set, the channel shall be carefully shaped and mortared to obtain a smooth channel. All channels shall be checked with the proper template.

Special approval must be obtained from the Engineer prior to any work on a junction box to be constructed in an existing street or other areas, which requires that the precast eccentric barrel be set directly into the freshly poured junction box base in order that the junction box may be backfilled the same day that it is excavated.

- 9.3 Installation: All joint surfaces of precast sections and face of junction box base shall be thoroughly clean prior to setting precast sections. These various sections shall be set in pre-formed plastic sealing gaskets. Care shall be taken to properly align the junction box section with the previously set section before it is lowered into position.

9.3.1.1 Installation of Gaskets:

7.3.1.1 During cold or wet weather, pass direct heat over the concrete joint surface lightly until ice, frost and moisture are removed and surface to be primed is dry and warm immediately before application of primer. Direct heat shall also be passed over plastic

gasket strips immediately prior to attaching them to joint surfaces and immediately prior to insertion of tongue into groove.

9.3.1.2 Apply one coat of primer to clean, dry joint surface (both tongue and groove) and allow to dry. Remove the paper wrapper from one side only of the two-piece wrapper on the gasket. The outside paper will protect the gasket and assure against stretching. Before setting the section in the trench, attached the plastic gasket strips end-to-end to the tongue or groove of each joint, forming a continuous gasket around the entire circumference of the junction box joint.

9.3.1.3 Handling of barrel sections after the plastic gasket has been affixed shall be carefully controlled to avoid bumping the gasket and thus displacing it or covering it with dirt or other foreign material. Any gaskets so disturbed shall be removed and replaced if damaged and repositioned if displaced.

9.4 Junction Box Throat: The maximum depth of the junction box throat shall be twelve (12) inches, measured from the top of the manhole cover to the lower extremity of the throat of the top of the cone section.

The throat shall be constructed by use of appropriately sized reinforced concrete grade rings that will bring the junction box cover to finished grade surface. No plastic sealing gaskets shall be used for jointing grade or extension rings in place.

9.5 Backfilling: All junction boxes shall be backfilled in conformance with the requirements of Section 19-3 of the Standard Specifications. All backfill under, around and at least three (3) inches over all pipelines located within five (5) feet of structure bases shall be compacted prior to barrel section placements. All junction boxes shall be constructed to subgrade prior to compacting adjoining sewer pipeline trench and/or structure backfill. All junction boxes shall be backfilled with structural backfill. Structural backfill shall be in accordance with the details shown on the plans.

9.6 Junction Box Frame and Collar: Junction box collars are intended to be poured against native, undisturbed earth or compacted structure backfill material, which has been excavated to the dimensions shown on the drawings. If the Contractor over-excavates beyond or otherwise cannot maintain the horizontal or vertical dimensions shown on the plans, he shall construct forms to the specified dimensions prior to placement of concrete for the collar.

When completed, the top of the junction box cover shall be accurately brought to the elevation called for on the plans, or if no elevation is specified, shall be brought flush with the surface of the surrounding ground or pavement, or to the height above grade shown on the plans for junction box in easement areas and ditches, or as directed by the Engineer.

9.7 Measurement:

9.7.1 Measurement - Junction Boxes: Junction boxes will be measured as junction boxes.

9.8 Payment - Junction Boxes and Appurtenances: The contract price per each for concrete sewer junction boxes shall include full compensation for all saw cutting, structure excavation, structure backfill, bar reinforcing steel and concrete, miscellaneous iron and steel (including all frames and covers, steps), bypassing of sewage flow, connecting pipes entering and leaving junction box, channeling of flows at bottom of box, all pavement replacement and all other labor, materials, tools, equipment, and incidentals required to complete sewer structures complete in place and no additional compensation will be allowed thereof.

10. STUBS: Where stubs are indicated on the plans, or directed to be installed by the Engineer such stubs will

be measured and paid per linear foot of sewer pipe installed.

11. TESTING OF SEWERS:

9.1 General: All leakage tests shall be completed and approved prior to placing of permanent resurfacing.

9.2 Air Testing: The new pipe shall be air tested. Air tests shall be conducted in accordance with the test procedure and details described on the District Standard Specifications or as directed by the Engineer.

9.3 Television Inspection: After completion of construction of the pipeline and prior to final pavement restoration, the Contractor shall inspect the new pipeline for obstructions and shall clean the new line using the Wayne Sewer Ball Method or other approved method. The Contractor shall inspect the new line by television camera. Television inspection shall be witnessed by the Engineer and shall be performed by a television inspection form acceptable to the Engineer. The costs for such television inspection of the line shall be included in the cost for installation of the sewer line and no additional payment will be made therefore. After completion of television inspection, Contractor shall submit TV logs and video to the District for review.

SECTION 2C

PAVING

PART 1 - GENERAL

1. **GENERAL:** The work to be done under this section consists of the restoration of existing paved and finished surfaces including restoration of pavement markings upon completion of pipeline installations.

Trenches in existing streets shall be resurfaced to the dimensions and with the type and thickness of bases, surfacing and pavement in accordance with the provisions and requirements of the appropriate encroachment and/or construction permit.

PART 2 - PRODUCTS

2. **AGGREGATE BASE:** Aggregate base shall be Class 2 conforming to the requirements for 3/4 inch maximum gradation as contained in Section 26 of the Standard Specifications. Recycled Class 2 aggregate base will not be allowed.
3. **ASPHALT CONCRETE:** Asphalt concrete (AC) shall be Type B, 3/4 inch maximum, medium mix conforming to Section 39 of the Standard Specifications.
4. **CONCRETE:** Concrete placed to restore concrete driveways and walks shall be in conformance with Section 3A - CONCRETE of these Specifications.
5. **TRAFFIC MARKINGS:** Paints and traffic marking materials used to restore existing markings shall conform to the requirements of Section 84 of the Standard Specifications.

PART 3 - EXECUTION

6. TRENCH RESURFACING:

6.1 Paved Public Roads: Trenches in paved public roads shall be resurfaced in accordance with the provisions and requirements of the appropriate encroachment and/or construction permit with a minimum of four (4) inches of AC placed over six (6) inches of Class 2 Aggregate Base compacted to 95 percent relative compaction. In areas where the depth from the finished pavement elevation to the top of the pipe or concrete encasement is less than twenty (20) inches, the pavement section shall be four (4) inches of AC placed over Class 2 Aggregate Base placed from the top of the pipe or encasement to four (4) inches below the finished grade and shall be compacted to 95 percent relative compaction.

6.2 Paint Binder: Paint binder shall be applied to the vertical surfaces of all existing pavement, curbs, gutters and construction joints in the surfacing against which additional material is to be placed in conformance with Section 39-4.02 of the Standard Specifications.

7. **TRAFFIC MARKINGS:** Existing traffic markings of centerline or edge striplings, stop bars and cross walks shall be remarked with similar materials and design wherever markings are removed, obliterated or otherwise damaged by the Contractor's operations. Crosswalks and stop bars shall be completely remarked. Centerline or edge strips shall be replaced as required.
8. **INDUCTIVE LOOP DETECTORS:** Contractor shall completely replace any inductive loop detector and lead-in cable that is cut or otherwise damaged as a result of construction operations. The loop detectors shall be Type "A" per CALTRANS Standard Plan ES5B and shall conform to provisions of Section 86-5.01A of the

Standard Specifications.

9. MEASUREMENT AND PAYMENT: All costs for permanent resurfacing of sewer line trenches, shall be paid at the unit prices per cubic yard of trench for asphalt concrete, concrete or aggregate base.

Detector loops that require replacement as a result of damage not directly caused by normally required pavement cutting as described in Section 2A of these Technical Conditions shall be replaced by the Contractor at his own expense and as directed by the Engineer .

SECTION 2D

CONCRETE

PART 1 - GENERAL

1. **APPLICABLE PUBLICATIONS:** The publications listed below form a part of this specification to the extent referenced. The publications are referred to in the text by the basic designation only:

1.1 American Concrete Institute (ACI) Standards:

ACI 318 Building Code Requirements for Reinforced Concrete

SP-66 ACI Detailing Manual - 1980

1.2 American Society for Testing and Materials (ASTM) Publications:

C 94- Ready-Mixed Concrete

C 150- Portland Cement

2. **GENERAL:** The work shall be in conformance with ACI 318; part entitled "Construction Requirements," except as specified herein. Concrete shall conform to ASTM C 94, except as hereinafter specified. The concrete shall not be placed until the underground and/or embedded items have been inspected, tested for mechanical operation, and checked for accuracy of position and alignment as a Contractor Quality Control item.

3. **STORAGE:** Materials shall be stored so as not to deteriorate or become contaminated.

PART 2 - PRODUCTS

4. MATERIALS:

4.1 Anchorage Materials: Anchorage items for anchoring work of other trades to concrete shall be of standard manufacture and of types to engage with anchors provided and installed under other sections.

4.2 Concrete Materials: Concrete materials shall conform to ASTM C 94. Only one brand of cement shall be used for exposed concrete surfaces of any individual structure.

4.2.1 Cement: Cement for concrete exposed to raw sewage shall conform to ASTM C 150, Type III with alkali content 0.6 percent or less. Cement for concrete not exposed to raw sewage shall conform to ASTM C 150, Type II.

4.2.2 Fly Ash: Fly ash may be used in addition to the cement required. If used, it shall conform to ASTM C 618, shall be Class F (non-cementitious) and shall not exceed fifteen (15%) of the weight of the cement used.

4.2.3 Aggregates: Coarse aggregate shall be on one maximum size the least of the following: 1/5 the narrowest dimension of the member, 3/4 minimum clear spacing between reinforcing bars or between bars and forms, or 1/3 the slab depth.

Aggregates shall conform to the requirements of ASTM Designation C 33.

4.3 Curing Materials: Curing materials shall be absorptive materials, impervious sheet or membrane

forming curing compound. Absorptive materials shall be burlap, jute, or fabric-type mats. Impervious sheet shall be white opaque polyethylene, 4-mil thick, waterproof kraft paper, or polyethylene-coated burlap. Membrane forming curing compound shall be of commercial formulation, sprayable, nontoxic, and will form a film highly resistant to moisture loss from concrete while curing and will dry within 4 hours. Compound shall be clear with fugitive dye, resin-base or chlorinated-rubber-base-type.

4.4 Form Coating: Form coating shall be nonstaining form oil, or form release agent that will not deleteriously affect concrete surfaces nor impair subsequent applications.

4.5 Form Materials: Form materials shall be plywood or hardboard especially made for concrete form use or other materials that will produce the specified finished without adversely affecting the concrete surfaces.

4.6 Form Ties: Form ties shall be metal, factory-fabricated removable or snap-off, that will leave holes not less than 1/4 inch, nor more than one (1) inch in diameter, and not more than one (1) inch deep. That portion of the tie remaining permanently in the concrete shall not project beyond the surface of the concrete and shall be recessed at least one (1) inch from any concrete surface that will be exposed, painted, damp proofed, or will receive direct applications of plaster.

4.7 Joint Sealant: Joint sealant shall be hot or cold applied, made specifically for sealing joints in concrete against moisture infiltration.

4.8 Reinforcement: Reinforcement bars shall be formed, Grade 40 billet or axle steel, or Grade 50 rail steel. Mesh shall be welded steel wire fabric with wires at right angles to each other and shall be sheet type only.

5. CONCRETE QUALITY: Concrete and ingredients quality, batching, and mixing shall conform to requirements of ASTM C 94 as designated in Alternate No. 2 of C 94 and the proportioning of concrete mixes to meet the requirements specified shall be the Contractor's responsibility.

5.1 Compressive Strength: Compressive strength in 28 days shall be 3,000 psi for reinforced concrete, and 2,500 psi for non-reinforced concrete. The compressive strengths shall be reached in seven (7) days when high-early-strength cement is used. Six (6) sack minimum of cement shall be used for all concrete except for thrust blocks.

5.2 Entrained-Air Content: Entrained-air content of concrete shall be maintained at four (4) to six (6) percent by volume of concrete.

5.3 Slump: Slump shall be three (3) to four (4) inches for walls and two (2) to three (3) inches for slabs on grade and for other work.

PART 3 - EXECUTION

6. FORM WORK: Form work shall provide for concrete conforming accurately to the indicated shapes, lines, dimensions, and with surfaces free of offset, waviness, or bulges. Where surfaces are to be exposed or painted, panels shall be manufacturer's stock size material, using smaller panels cut to required dimensions only where required by openings and joints. Panel joint in exposed or painted work shall occur at control joints, including alignment with masonry control joints and construction joints. Exposed corners shall be chamfered, beveled, or rounded by moldings placed in the forms. Surfaces shall be thoroughly cleaned and coated before each use. Forms shall be removed at a time and in a manner that will not injure the concrete.

7. REINFORCEMENT: Reinforcement detailing and placement shall conform to ACI SP-66 and ACI 318. Reinforcement shall be installed two (2) inches clear on each side of joints in slabs on grade and perimeter joints. Wire-mesh reinforcement shall be sheet type and be continuous between joints in slabs on grade. Laps shall be at

least one full mesh plus two (2) inches; staggered to avoid continuous lap in either direction; and securely wired or clipped with the standard clips. Mesh shall be supported on precast concrete units in a manner that will support the mesh at the minimum height indicated. Dowels and tie bars in slabs on grade shall be installed at right angles to joints; accurately aligned parallel to the finished surface; and rigidly held in place and supported during concrete placement.

8. INSTALLATION OF ANCHORAGE ITEMS: Anchorage items shall be number, size, and location to ensure sufficient anchorage for purpose intended. Contractor shall furnish details to Engineer for review.

9. PLACING: Concrete footings and exterior slabs shall be placed upon clean undisturbed surfaces free from frost, ice, and water. Dry or previous surfaces receiving concrete shall be covered with impervious sheet materials. Concrete may be placed directly on impervious surfaces that are thoroughly moistened but not muddy. Concrete shall be placed in layers not over twelve (12) inches deep. Concrete shall be protected from freezing. Concrete to receive other construction shall be screeded to the proper level.

10. CONSOLIDATION OF CONCRETE: Consolidation of concrete shall be with internal concrete vibrators supplemented by hand spading, rodding, and tamping. Vibrating equipment shall be adequate to thoroughly consolidate the concrete. Slabs four (4) inches and less in thickness shall not be consolidated by internal vibration; properly designed vibrating screeds or other approved technique shall be used.

11. FIELD QUALITY CONTROL TESTS: Sampling, preparation of test specimens, and testing will be performed by the District.

11.1 Reinforcement: Mill certificates of tests on steel reinforcing bars will not be required for this project.

11.2 Concrete Cylinders: Number and frequency of test cylinders will be decided by the Engineer. If the average strengths of three (3) consecutive tests fall below the specified design strength, the Engineer may require such changes in the proportions of the concrete mix as will be necessary to obtain the required strength. Cylinders required for form work control tests shall be provided in addition to those otherwise required, and shall be field cured at least three-fourths of the proposed period before removal of forms.

12. FINISHES: Fins and loose material shall be removed. Unsound concrete, voids over 1/2 inch in diameter, and tie-rod and bolt holes shall be cut back to solid concrete, reamed, brush coated with cement grout, and filled solid with a stiff portland cement-sand-mortar mix. Patchwork shall finish flush with adjoining concrete surfaces and where exposed, shall match adjoining surfaces in texture and color. Patchwork shall be cured for 72 hours, white portland cement shall be used as needed to attain color match.

13. CURING: Curing shall start as soon as free water has disappeared from concrete surfaces after placing and finishing. Curing materials shall be applied and maintained so as to protect the concrete from moisture loss for seven (7) days. Curing shall be accomplished by moist curing, impervious sheet or membrane forming curing compound. Unformed surfaces shall be covered with absorptive materials wetted before placing. Absorptive materials or forms used in curing shall be kept continually wet. Concrete surfaces shall be thoroughly wetted before covering with impervious sheet materials. Membrane forming curing compound shall be applied with mechanical spraying equipment at a coverage of not more than 200 square feet per gallon. Surfaces damaged during curing shall be resprayed.

(This Page Left Blank Intentionally)

SECTION 2E

TRENCHLESS REPLACEMENT (PIPE SLIPLINING/BURSTING)

PART 1 - GENERAL

1. **GENERAL:** Work under this section shall consist of furnishing all labor, materials, equipment, and supervision to perform all work necessary to replace the existing sanitary sewers in backyard easements, public right-of-ways and other locations as noted on the plans and in accordance with these Specifications. The required method of replacement are pipe bursting utilizing mechanically pulled bursting devices or sliplining using a mechanically pulling head attached to the liner pipe which is inserted into the existing sewer line. Air-driven (pneumatic) bursting tools will not be permitted on this project. New replacement sewer pipeline materials used shall be High-Density Polyethylene (HDPE) pipe and shall be installed uniformly and continuously along the entire length between adjacent manholes unless otherwise shown on the plans. The pipe sliplining/bursting work shall consist of, but not necessarily be limited to, performing the following tasks where specified. The Contractor's attention is directed to the Special Conditions regarding patents and the acquisition of licenses necessary for the use thereof.

- 1.1 Sewage flow bypassing during the pipe sliplining/burst operations,
- 1.2 Cleaning and television inspection of the existing pipelines,
- 1.3 Locating, exposing and disconnection of all existing laterals,
- 1.4 Existing pipe sliplining/burst and new pipe pulling,
- 1.5 Re-connection of existing live laterals,
- 1.6 Rehabilitation and/or replacement of manhole or rodding inlet structures, and
- 1.7 Air test and television inspection,
- 1.7 Landscape and surface restoration.

2. **APPLICABLE PUBLICATIONS:** The publications listed below form a part of these specifications to the extent referenced. The publications are referred to in the text by the basic designation only.

- 2.1 American Society for Testing and Materials (ASTM) Publications:
ASTM C 478
ASTM D 638
ASTM D 2657-67
ASTM D 3350
ASTM F-585
ASTM D-3035

3. **APPROVALS:** Special approvals required under this section of the work include:

- 3.1. Equipment and method of flow bypassing.

PART 2 - EQUIPMENT

4. PIPE SLIPLINING/BURSTING UNIT: The sliplining/bursting unit or mole shall be made of steel and of a diameter that is not more than ¼ inch less than the nominal internal diameter of the carrier pipe. The Contractor shall submit fabrication dimensions and details of the bursting unit.

The backside of the mole shall be firmly connected to the new liner pipe to be pulled in place of the existing sewer.

Where sliplining, it is not intended to burst the existing pipeline while placing the liner pipe, although some breakage will occur.

- 4.1 The design and shape of the mole shall be such that the existing carrier pipe will be preserved to the greatest extent possible and the liner is to be protected from sharp broken bits of pipe.
- 4.2 The method of connection of the inserted pipe to the mole shall be so that stresses transmitted to the inserted pipe are not damaging to the pipe, nor will they exceed the tensile capacity of the pipe.
- 4.3 Provisions shall be made in the equipment to remotely start and stop the mole should it become necessary to temporarily cease moling operations.
- 4.4 Measures shall be taken to ensure that the pipe does not become separated from the mole.

5. SLIPLINING/BURSTING: The polyethylene liner shall be inserted into the existing sewer line with a pulling unit and steel cable connected to the end of the liner by use of an appropriate pulling head (mole). A second pulling head may be attached to the line if necessary. Length of the liner to be inserted at any one time shall be governed by the pulling unit capacity and power available and consideration of the size and condition of the sewer.

- 5.1 Preparatory Procedures for Pipe Sliplining/Bursting:
 - 5.1.1. Cleaning: Prior to any pipe sliplining/bursting of a line so designated, it shall be the responsibility of the Contractor to clean debris out of the sewer line sufficient to allow passage of the liner pipe. Debris includes congestion material of any kind, rocks, broken bits of pipe, entering roots and any other material affecting passage of the pipe sliplining/bursting tools and materials. Costs for the cleaning shall be included in the unit price bid for pipe sliplining/bursting and no additional costs will be allowed therefore.
 - 5.1.2. Television Inspection: Internal inspection of the lines to the extent feasible has been conducted by the District. Copies of the reports and videotape records may be viewed by the Contractor in planning and execution of the work. The District makes no representation as to the accuracy of the District tapes. The Contractor shall televise or otherwise inspect the line and satisfy himself as to the conditions of work and the methodology to be applied to complete the project. Costs of televising shall be included in the unit price bid for pipe sliplining/bursting.
 - 5.1.3. Proofing the existing sewer line: Prior to sliplining operations on any sewer line segment, the Contractor shall proof the line with a suitable proofing device to verify the lines ability to be inserted with a liner without causing significant damage to the liner. The proofing device shall be of a diameter not less than ¼ inch greater than the outside diameter of the liner pipe. Proofing shall be included in the unit prices bid for sliplining. Proofing tests shall be witnessed by and approved by the Engineer prior to lining operations.
 - 5.1.4. Point repairs: If during the preparatory procedures to pipe sliplining/burst, conditions are

found in the existing sewer line that prohibit the passage of the liner pipe without damaging the liner, a point repair shall be made to realign the pipe and allow passage of the proofing device and the HDPE liner. For purposes of measurement and payment, a point repair shall consist of a 15 foot long trench excavation, sheeting and shoring, 8 feet of sewer line replacement, pipe bedding, backfilling and surface restoration. Payment for point repairs shall be at the unit price for point repairs listed in the bid proposal.

6. PULLING UNIT: The pulling unit shall be operated to provide recurrent pull to the pipe sliplining/bursting unit in order that it may operate in an efficient manner with a minimum of recoil. It shall ensure directional stability in keeping the moling unit in line.

- 6.1 The pulling unit shall be on the constant load type, but shall be fitted with a direct reading load gauge to measure the load. It shall also be fitted with a device to automatically disengage when loading exceeds a preset maximum load.
- 6.2 Contractor shall supply sufficient cable in one continuous length so that the pull may be continuous between pulling points.
- 6.3 The Contractor shall also provide a system of guide pulleys and bracing at each manhole to minimize contact of cable with the existing sewer between manholes.
- 6.4 A nose cone shall be fixed to the first pipe or the head of the mole and shall be fitted with a swivel attachment to reduce the twist transmission between the cable and the nose cone.
- 6.5 Supports to the trench sheets in the insertion trench shall remain completely separate from the pipe support system and shall be so designed that neither the pipe nor the cable shall be in contact with them at any time.
- 6.6 Proper clearance shall be provided below the existing pipe to allow for the proper use of pulling unit.

PART 3 - MATERIAL

7. PIPE AND FITTING: Polyethylene pipe and fittings shall be Plexco EHMW PE 3408 SDR 21 or SDR 17 as noted on the plans or approved equal, consisting of virgin high molecular weight polyethylene, specified under ASTM D3350 as having a cell classification of PE345434C. Manhole adapter rings shall conform to recommendations of manufacturer of PE pipe supplied.

8. PIPE JOINT: Pipe shall be fuse welded in accordance with ASTM D2657-67. The joints shall be leak proof, thermal, fuse joints. All fusing shall be done using tools recommended by the pipe supplier and approved by the District. Operators shall be certified by the pipe manufacturer. The fusing machine shall have hydraulic pressure control for fusing two pipe ends together. The ends of pipe shall be trimmed to form perpendicular faces prior to fusing. The heating plate on the fusing machine shall be electrically heated and thermostatically controlled and shall contain a temperature gauge for monitoring temperature. The heating plate shall be subject to periodic inspection, using a temperature stick, to assure even heating.

The tensile strength of yield of the butt fusion joints shall not be less than the pipe. A specimen of pipe cut across the butt fusion joints shall be tested in accordance with ASTM C638.

Any material may be rejected for failure to meet any of the requirements of this specification. The acceptance of any deviation from these specifications shall be subject to the approval of the District.

The internal bead shall be controlled to protrude no greater than 1/8 inch circumferentially on the inside wall of the pipe barrel.

9. CONCRETE: Concrete shall conform to the requirements of SECTION 2D, CONCRETE.

10. MANHOLES: Manholes shall conform to the requirements of SECTION 2B: SANITARY SEWERS.

PART 4 - EXECUTION

11. SEWAGE BYPASSING: All work under the contract shall be done without interruption of service, except when approved the District. Such interruption of service shall be only for as long as a period as is reasonably required, and shall be carefully scheduled with operating personnel.

The Contractor shall be responsible for maintaining all flows within the system. The Contractor shall bypass the flows around those sections of pipe to be replaced. Certain individual services and laterals within the project areas may also require bypassing during the pipe bursting operations as determined by the District.

The bypass shall be made by plugging an existing upstream manhole if necessary and pumping the sewage into a downstream manhole or adjacent system. The pump and bypass lines shall be of adequate capacity and size to handle the flow. Contractor shall submit written list of equipment and materials and method proposed to be used for bypassing to District shall in no way be construed as relieving the Contractor of any responsibility under this contract as related to protection of the interests of the District and the general public.

At the end of each working day, a temporary tie-in shall be made between the replaced section by pipe bursting, service connection, and the existing system. The bypass plug will either be removed or the pumps will be manned on a 24-hour basis.

Under no circumstances shall the discharge of raw sewage to other than an approved sanitary sewer be allowed. Bypassing of untreated or partially treated wastewater to surface waters or drainage courses, is a violation against the law and will result in assessment of damages.

12. METHOD OF SLIPLINING/BURSTING: The method of pipe sliplining/bursting shall be limited to mechanically pulling a pipe-bursting device or tool, commonly known as a "mole," through the existing sewer pipes that are proposed for replacement. The mole is to be inserted in sewer section to be replaced, and shall be pulled by a pulling machine located in a pulling pit, located at a certain distance along the alignment of the sewer section under consideration, away from the mole insertion location. The mole shall pull behind it the new sewer pipe to be placed along the same horizontal and vertical alignments of the existing sewer. Existing manhole walls and channels shall be chipped out as needed to allow mole to be pulled through manholes.

13. MANHOLE CONNECTIONS: At the upstream and downstream ends of the pipe, it shall be cut in an approved manner so the two (2) inches protrudes into the manhole. The invert of the manhole shall be suitably prepared such that a smooth transition shall be made from the existing invert to the new pipe.

The new PE pipe and any existing pipe in use shall be connected to the existing manholes. The annular space between existing concrete base and manhole walls and ends of the PE pipe in the manholes, shall be filled with a link-seal coupling with stainless steel bolts and trim or packed to a depth of 8 inches with activated oakum saturated with a polyurethane sealant, then completely surfaced and sealed in concrete or non-shrinking patching grout, as detailed on the plans.

Payment for connection of sewer mains to manholes shall be included in the unit price bid and paid for the pipe sliplining/burst to be constructed under this contract. There will be no separate measurement or payment for manhole connections.

14. INSERTION AND PULLING PITS: The size, location and method of excavation of all pits on site shall be determined by the Contractor prior to the start of the project. Contractor shall be responsible to make arrangements as necessary with property owners for access to pits from public streets. The excavations shall be supported using trench sheets and speed shoring, or equivalent. The end of the launch pit on which the pusher forces are exerted shall be supported using 12 inches X 12 inches timbers to allow these forces to be dissipated into the

surrounding soil.

Contractor shall use the terminal locations along each major line segment as the location for entry or pulling pits and shall remove and replace manhole and/or rodding inlet structures currently at those locations, if necessary. Costs for the removal and replacement of manhole or rodding inlet structures shall be included in the appropriate bid item of the bid proposal.

In considering locations for intermediate access pits, the Contractor shall consider the size of the sewer, locations of obstructions and services, pulling distances, traffic conditions, and locations of utilities and sewer laterals. When possible, intermediate access excavations can coincide with building service connection excavations or critical obstructions in the sewer. The locations of the excavation points should be such as to minimize traffic disruption.

Insertion pits shall have a maximum slope of 2.5:1 entry slope and a maximum of 1.0:1 back slope (one way insertion only) and a pit floor length of 12 times the pipe diameter. Pit width shall be two (2) feet wider than the outer diameter of the pipe diameter, and shall have a back slope of 1.0:1. The slopes given are maximum and may have to be lessened depending on soil type, water table, whether or not sheeting is used, and other working conditions. A roller or rub shoe shall be installed at pipe entry to prevent pipe shatter as the pipe enters the existing line.

15. PIPE INSERTION:

- 15.1 The installation forces on the pipe shall be kept to a minimum.
- 15.2 Where a continuous length of pipeline is butt fused prior to insertion, the length of insertion pit shall be as defined below:
 - 15.2.1 The bottom of the pit shall be horizontal and its length shall not be less than 12 times the diameter of the pipe to be inserted.
 - 15.2.2 The rear sloping face of the pit shall be not less than 30 times the diameter of the pipe.
 - 15.2.3 The radius of curvature of the inserted pipe shall not be less than 30 times the diameter of the pipe.
- 15.3 Where a device is employed to exert force on the rear of the inserted pipe lengths, the force applied to the inserted pipe shall be evenly distributed around the wall of the pipe.
- 15.4 Maximum force applied to pipe shall be within stress limits of the pipe.
- 15.5 Where lengths of pipe are jointed and a device is employed to exert force to the rear of the inserted pipe lengths, precautions shall be taken by the Contractor to ensure that no buckling, crushing or twisting of the pipe occurs.
- 15.6 Where lengths of polyethylene pipe are pushed, there is no relaxation time required to allow pipe to return to its original length.

16. LATERALS: All lateral connections shall be located and exposed by the Contractor prior to pipe sliplining/burst, disconnected and “live” laterals then permanently reconnected to the new pipe after molding has been completed. Reconnection of laterals shall be accomplished from the ground surface by excavating a small opening approximately 4’ X 5’ to depth and dropping in speed shoring as required so the connections can be made safely.

All “live” service laterals shall be connected using wye or tee saddles constructed of the same materials as the new

sewer pipe and installed in accordance with the manufacturer's written instructions. The wye or tee saddles shall be fused onto the new sewer pipe. The lateral connection shall be watertight and shall have the same structural integrity as the new sewer pipe. The finished connection shall be flush with the new sewer and shall provide a smooth transition to the existing lateral pipe work. The existing lateral line shall be tied in with minimum bends or fittings.

16.1 Measurement:

16.1.1 Measurement - Locating Sewer Lateral: Locating sewer lateral shall be measured as the number of laterals located and exposed, which are connected to the main to be replaced.

16.1.2 Measurement - Live Sewer Lateral Reconnection: Sewer lateral reconnections shall be measured as the number of "live" lateral connections actually installed complete and accepted.

16.2 Payment:

16.2.1 Payment - Locating Sewer Lateral: The contract price per each for locating sewer lateral shall include full compensation for furnishing all labor, materials, equipment and tools required for the investigation, detection and exposing sewer laterals at the main. It shall also include disconnecting, backfilling, and abandonment of laterals not in use and landscape restoration.

16.2.2 Payment - Live Sewer Lateral Reconnection: The contract price per each for this item of work shall include full compensation for furnishing all labor, materials, equipment and tools required for the satisfactory reconnection of service laterals, complete, including connection to the new sewer pipe, pipe, fittings, jointing, backfilling, surface restoration, and all other tasks and costs incidental and necessary to complete the items as specified herein and as indicated.

17. MANHOLES: Manholes shall be in accordance with the applicable provisions of Section 2B: SANITARY SEWERS of these Technical Specifications.

18. BACKFILL AND COMPACTION: Insertion trenches in paved areas shall be backfilled and compacted in accordance with the applicable provisions of Section 2A: EXCAVATION, TRENCHING AND BACKFILLING.

18.1 Backfilling and Compaction in Areas Where HDPE Liner is Exposed. At all points where the new HDPE sewer pipe has been exposed, such as access shafts, service connections, outside of manholes, etc., the Contractor shall bed the exposed PE pipe in a compacted slurry cement bedding to a point three (3) inches over the top of the pipe. Contractor shall take necessary steps to control and avoid flotation of the pipe during the bedding procedure. Contractor may then backfill with suitable trench backfill material. Backfill shall be placed in layers not exceeding eight (8) inches in loose depth, each layer being thoroughly compacted before succeeding layers are placed.

Where an unstable or running soil condition occurs, such as in excavations below ground water, bedding material shall be used according to the trench section detail specified herein this contract. It may be necessary to increase the trench width to obtain the desired lateral support for the pipe. All costs associated with the backfilling and compaction of areas where the new HDPE sewer pipe has been exposed shall be included in the unit prices bid for pipe sliplining/bursting or lateral reconnection and no additional costs will be allowed therefore.

19. TESTING: The new pipe shall be air tested prior to the connection of laterals. Tests shall be conducted as per the procedures specified in the Special Conditions.

After backfilling, prior to asphalt concrete pavement all pipelines shall be inspected for obstructions and shall be cleaned. All pipelines shall be cleaned using the sewer ball method or a high-pressure hydroflusher. If the Contractor elects to use the high pressure hydroflusher, and if, in the opinion of the District, the lines are not cleaned sufficiently by hydroflushing, the Contractor shall re-clean the lines using the sewer ball method at his own expense. Additional costs for television inspection of the work after re-cleaning shall be borne by the Contractor.

After completion of construction and cleaning of the pipeline, prior to asphalt concrete pavement the Contractor shall inspect the new line by a television camera. Any breaks, leaks at joints or sags in sewer main to be repaired at the Contractor's expense. After completion of repairs, if any, the Contractor shall again inspect the line by a television camera to the satisfy

20. RESTORATION: After completion of backfill, all material not used therein shall be removed and disposed of by the Contractor in such a manner and at such point or points he may select, subject to the approval of the District. All roads, sidewalks, and other places on line of work shall be left free, clean and in good order. All removal and cleaning up shall be done by the Contractor without extra compensation, and, if he fails to do such work within a reasonable time, after receipt of notice, the work will be performed by the District, and the cost deducted out of monies due or to become due the Contractor.

All restoration shall be included in the Contractor's unit and/or lump sum prices bid. All cultivated areas, either landscaping, natural vegetation areas, fences and other surface improvements which are damaged by actions of the Contractor, shall be restored as nearly as possible to their original condition with no extra costs to the Owner. Damage to property outside of specified construction limits shall be the responsibility of the Contractor and restoration of same shall be made at the Contractor's expense.

SECTION 2F

TRENCHLESS REPLACEMENT CURED-IN-PLACE PIPE (CIPP)

PART 1 – GENERAL

1. **GENERAL:** Work under this section shall consist of furnishing all labor, materials, equipment, and supervision to perform all work necessary to replace the existing sanitary sewers in the backyard easements, public right-of-ways and other locations as noted on the plans and in accordance with these Specifications. The required method of replacement is cured-in-place pipe installed at the locations shown on the Drawings. The work shall consist of, but not necessarily be limited to, performing the following tasks where specified.
 - 1.1 Sewage flow bypassing during the cured-in-place pipe operations,
 - 1.2 Cleaning and television inspection of the existing pipelines,
 - 1.3 Locating of all existing laterals,
 - 1.4 Existing pipe lining with cured-in-place pipe,
 - 1.5 Re-connection of existing live laterals,
 - 1.6 Reconnection, rehabilitation and/or replacement of manhole or rodding inlet structures,
 - 1.7 Air test and television inspection, and
 - 1.8 Landscape and surface restoration.

2. **APPLICABLE PUBLICATIONS:** The publications listed below form a part of these specifications to the extent referenced and shall be the latest edition thereof. The publications are referred to in the text by the basic designation only.
 - 2.1 American Society for Testing and Materials (ASTM) Publications:

ASTM D 256	Standard Test Methods for Impact Resistance of Plastics and Electrical Insulating Materials
ASTM D 543	Resistance of Plastics to Chemical Reagents
ASTM D 638	Tensile Properties of Plastics
ASTM D 732	Standard Test Method for Shear Strength of Plastics by Punch Tool
ASTM D 790	Flexural Properties of Unreinforced and Reinforced Plastics and Electrical Insulating Materials
ASTM D 2990	Tensile, Compressive, and Flexural Creep and Creep-Rupture of Plastics
ASTM D 3567	Standard Practice for Determining Dimensions of “Fiberglass” (Glass-Fiber-Reinforced Thermosetting Resin) Pipe and Fittings
ASTM D 5813	Cured-in-Place Thermosetting Resin Sewer Pipe
ASTM F 1216	Standard Practice for Rehabilitation of Existing Pipelines and Conduits by the Inversion and Curing of Resin-Impregnated Tube (1991 Revision)
ASTM F 1743	Standard Practice for Rehabilitation of Existing Pipelines and Conduits by Pulled-in-Place Installation of Cured-in-Place Thermosetting Resin Pipe
ASTM F 2019	Standard Practice for Rehabilitation of Existing Pipelines and Conduits by Pulled-in-Place Installation of Glass reinforced Plastic (GRP) Cured-in-Place Thermosetting Resin Pipe (CIPP)

 - 2.2 National Association of Sewer Service Companies (NASSCO): Recommended Specifications for Sewer Collection System Rehabilitation.

3. **APPROVALS:** Special approvals required under this section of the work include:
 - 3.1. Equipment and method of flow bypassing.

PART 2 – DESCRIPTION

4. **CURED-IN-PLACE PIPE:** Installation of the Cured-In-Place Pipe shall be accomplished by the use of an inversion process or a winched-in application. The reconstruction of the existing line shall be accomplished by installing a flexible tube which is first impregnated with a thermosetting resin. The tube is either inverted into the pipeline by using hydrostatic head (water pressure), compressed air pressure or some other approved inversion method, or pulled into the pipeline from manhole to manhole using mechanical equipment (winch). After full insertion, the tube is cured by circulating hot water or introducing controlled air or steam throughout the length of the tube to cure it into a hard, impermeable pipe. This "pipe" shall extend the full length of the original sewer, and shall provide a structurally sound, jointless, tight-fitting, watertight pipe within a pipe.

4.1 Preparatory Procedures for Cured-In-Place Pipe:

- 4.1.1 Cleaning: Prior to any pipe lining so designated, it shall be the responsibility of the Contractor to clean all debris out of the sewer line. Debris includes congestion material of any kind, rocks, broken bits of pipe, entering roots and any other material that would inhibit proper lining. Costs for the cleaning shall be included in the unit price bid for Cured-In-Place Pipe and no additional costs will be allowed therefore.
- 4.1.2 Television Inspection: Internal inspection of the lines to the extent feasible has been conducted by the District. Copies of the reports may be viewed by the Contractor in planning and execution of the work. The District makes no representation as to the accuracy of the reports. The Contractor shall televise or otherwise inspect the line and satisfy himself as to the conditions of work and the methodology to be applied to complete the project. Costs of televising shall be included in the unit price bid for Cured-In-Place Pipe.
- 4.1.3 Point repairs: If during the preparatory procedures to lining, conditions are found in the existing sewer line that prohibits maintaining the designed hydraulic cross section, a point repair shall be made. For purposes of measurement and payment, a point repair shall consist of a 15 foot long trench excavation, sheeting and shoring, 8 feet of sewer line replacement, pipe bedding, backfilling and surface restoration. Payment for point repairs shall be at the unit price for point repairs listed in the bid proposal. If no unit price for point repairs is included in the contract, payment for point repairs shall be by Contract Change Order.

PART 3 - MATERIAL

All materials and procedures used in the cured-in-place pipe rehabilitation process shall be equal to or exceed the manufacturer's standards.

5. **TUBE:** The liner tube shall be fabricated to meet performance requirements as specified in section 7, Finished and Cured Liner Properties, of this specification.

FIBER FELT TUBE SYSTEM: The felt tube shall be a thermoplastic polyester or acrylic tube consisting of one or more layers of flexible needled felt or an equivalent woven and/or non-woven material capable of carrying resin, and with sufficient needling and cross lapping and strength to withstand the installation pressures and curing temperatures. The felt tube to be furnished shall be compatible with the resin and catalyst systems to be utilized.

The tube shall be free of tears, holes, cuts, foreign materials and other defects and will be subject to inspection by the City.

The finished lining shall consist of an inner plastic coating and an outer polyester felt layer (or layers) impregnated with a thermosetting resin and fabricated to fit tight against the existing pipe wall. An allowance shall be made for circumferential stretching during inversion.

Contractor shall determine the minimum tube length necessary to effectively span the designated run between manholes, unless otherwise specified. Contractor shall field verify the lengths in the field prior to impregnation of the tube with resin, to insure that the tube will have sufficient length to extend the entire length of run.

6. **RESIN/CATALYST:** The resin used shall be compatible with the rehabilitation process used, and designed for a wastewater environment. The resin shall be able to cure in the presence or absence of water, and the initiation temperature for cure shall be as recommended by the resin manufacturer and approved by the Engineer. The resin shall have sufficient thixotropic properties to obtain non-draining characteristics when impregnated into the fiber fabric.

Unless otherwise specified or approved by the Engineer, the resin shall be a polyester system for typical residential sewage and shall be able to meet the service conditions specified for the tube system. For commercial, industrial, or other areas with a potential for sewage that affects polyester, epoxy or vinyl ester resin shall be required as determined by the City.

The Engineer shall also be informed in advance, for verification and inspection of the resin material at the "wet out" of the tube. The inspection shall be at the discretion of the Engineer, which shall not relieve the Contractor of his responsibilities. The wet-out procedure shall utilize the resin and catalyst in sufficient quantities to ensure complete impregnation of the liner and provide the properties specified in Section 7, Finished and Cured Liner Properties.

The catalyst system shall be compatible with the resin and other materials to be utilized in the rehabilitation process. Quantity and type of catalyst shall be selected based on the curing conditions and recommendations of the resin manufacturer.

7. **FINISHED AND CURED LINER PROPERTIES:** The finished cured-in-place pipe liner shall fit tightly and neatly against the existing pipe walls. The liner shall be fabricated from materials which, when cured, will be suitable for continuous service in sewerage environments containing hydrogen sulfide, carbon monoxide, carbon dioxide, methane, dilute (10%) sulfuric acid at an average wastewater temperature of 80°F, dilute (10%) phosphoric acid, petroleum hydrocarbons, gasoline, vegetable oil, tap water (pH 6.5 - 9), up to 1 hour per day exposure to 5 percent sodium hydroxide up to a pH of 11, moisture saturation, and

external exposure to soil bacteria and chemical attack which may be due to materials in the surrounding ground or sewage within.

The cured-in-place pipe system shall conform to and comply with the requirements above, and meet or exceed the minimum standard physical properties (in accordance with ASTM D790) as follows:

<u>Property</u>	<u>Minimum</u>	<u>Enhanced Resin</u>
Modulus of Elasticity	1724 Mpa (250,000 psi)	2758 Mpa (400,000 psi)
Flexural Stress	31 Mpa (4,500 psi)	31 Mpa (4,500 psi)

Structural CIPP section requirements shall be in accordance with the design equations in Appendix X1 of ASTM F 1216 and the following design parameters:

1. Design Safety Factor (typically used value) = 2.0
2. Retention Factor for Long-Term Flexural Modulus to be used in Design = 1% - 60% (As determined by long-term tests described above and approved by the Engineer).
3. Groundwater Depth (above invert of existing pipe) to be determined by the Contractor.
4. Soil Depth (above crown of existing pipe) to be determined by the Contractor.
5. Poisson's Ratio = 0.3
6. Enhancement Factor (K) = 7
7. DR = Dimension Ratio = Diameter / thickness -> $t = D/DR$
8. Effective reduction of Ei modulus to approximate effects of creep = 50%
9. Ovality % = $100 \times (\text{Mean Dia.} - \text{Minimum Dia.}) / \text{Mean Dia.}$
 - 2% ovality is typically assumed when the host pipe measurements have not been field verified.
10. Any layers of the tube that are not saturated with resin prior to insertion into the existing pipe shall not be included in the structural CIPP wall thickness computation.

8. CONCRETE: Concrete shall conform to the requirements of SECTION 2D, CONCRETE.

9. MANHOLES: Manholes shall conform to the requirements of SECTION 2B: SANITARY SEWERS.

PART 4 – EXECUTION

- 10. SEWAGE BYPASSING:** All work under the contract shall be done without interruption of service, except when approved the District. Such interruption of service shall be only for as long as a period as is reasonably required, and shall be carefully scheduled with operating personnel.

The Contractor shall be responsible for maintaining all flows within the system. The Contractor shall bypass the flows around those sections of pipe to be replaced. Certain individual services and laterals within the project areas may also require bypassing during operations as determined by the District.

The bypass shall be made by plugging an existing upstream manhole if necessary and pumping the sewage into a downstream manhole or adjacent system. The pump and bypass lines shall be of adequate capacity and size to handle the flow. Contractor shall submit written list of equipment and materials and method proposed to be used for bypassing to District shall in no way be construed as relieving the Contractor of any responsibility under this contract as related to protection of the interests of the District and the general public.

At the end of each working day, a temporary tie-in shall be made between the replaced section, service connection, and the existing system. The bypass plug will either be removed or the pumps will be manned on a 24-hour basis.

Under no circumstances shall the discharge of raw sewage to other than an approved sanitary sewer be allowed. Bypassing of untreated or partially treated wastewater to surface waters or drainage courses, is a violation against the law and will result in assessment of damages.

- 11. INSTALLATION:** The Contractor's operations to furnish and install the lining shall be in strict conformance with the component materials and manufacturer's recommendations.

The host pipeline shall be cleaned and televised in accordance with Section 4, Cured-In-Place Pipe. The outside diameter of the tube being inserted shall be properly sized to allow for expansion so that the CIPP liner can fit tightly against the host pipe.

The tube shall be installed through the existing manholes, in accordance with the manufacturer's recommendations and procedures. The finished pipe on mainline reaches shall be continuous over the entire length between manholes. A sealing material compatible with the liner shall be installed at the entrance to each manhole between the tube and the existing pipe to provide a watertight seal.

The Contractor shall submit to the Engineer a detailed plan of construction including the installation procedures, equipment set-up, and the locations of the proposed access points for approval. The Contractor shall have an approved plan of construction prior to commencing any construction.

During the curing process, the Contractor shall keep logs, charts and/or graphs of the liner temperatures at the upstream and downstream manholes to insure that proper temperatures and cure times have been achieved. These documents may be required by the Engineer at any time during and after the curing process.

Any evidence of infiltration between the service connection and the existing pipe shall be corrected by the Contractor. The method of correction shall be submitted and approved by the Engineer.

- 12. LATERALS:** Immediately after curing of the tube and after testing, within the same working day, the Contractor shall reinstate all existing active service connections, without excavation, by means of an approved remote control cutting device from within the sewer. An initial relief hole shall first be cut on all

services, followed by finish cutting to the approximate original size and shape. The service connection shall be brushed to remove rough edges, strings or other pipe defects that would prevent solids from flowing freely. The Contractor shall have a back-up remote control cutting device on site in case of malfunction.

The lateral connection shall be watertight and shall have the same structural integrity as the new sewer pipe. The finished connection shall be flush with the new sewer and shall provide a smooth transition to the existing lateral pipe work.

12.1 Measurement:

12.1.1 Measurement - Locating Sewer Lateral: Locating sewer lateral shall be measured as the number of laterals located and exposed, which are connected to the main to be replaced.

12.1.2 Measurement - Live Sewer Lateral Reconnection: Sewer lateral reconnections shall be measured as the number of "live" lateral connections actually installed complete and accepted.

12.2 Payment:

12.2.1 Payment - Locating Sewer Lateral: The contract price per each for locating sewer lateral shall include full compensation for furnishing all labor, materials, equipment and tools required for the investigation and detection of sewer laterals at the main.

12.2.2 Payment - Live Sewer Lateral Reconnection: The contract price per each for this item of work shall include full compensation for furnishing all labor, materials, equipment and tools required for the satisfactory reconnection of service laterals, complete, including connection to the new sewer pipe and all other tasks and costs incidental and necessary to complete the items as specified herein and as indicated.

13. MANHOLES: Manholes shall be in accordance with the applicable provisions of Section 2B: SANITARY SEWERS of these Technical Specifications.

14. TESTING: After curing of the tube and before any service connections are reinstated, the Contractor shall perform the following hydrostatic exfiltration test on the tube to determine if it is watertight.

14.1 Hydrostatic Exfiltration Test

The leakage testing shall be in conformance with ASTM F1216. The test shall be conducted for a minimum of one hour.

14.2 Pipe Samples Testing

The Contractor shall prepare a minimum of one CIPP sample for testing per inversion in accordance with ASTM F1216 and ASTM F1743. Sample(s) shall conform to the following two methods:

1. For host pipe diameters 18" and smaller, the sample should be cut from a section of cured CIPP at an intermediate manhole or at the termination point that has been inverted through a like diameter pipe which has been held in place by a suitable heat sink, such as sandbags.
2. For host pipes larger than 18" in diameter, the sample should be fabricated from material taken from the tube and the resin/catalyst system used and cured in a clamped mold placed in the down tube.

The samples for each of these cases should be large enough to provide a minimum of three specimens. The samples shall be tested by a certified independent third party testing laboratory. The lab shall provide the Engineer for approval with certified test results. The following test procedure shall be performed after the sample is cured and removed:

1. Short-Term Flexural (Bending) Properties – The initial tangent flexural modulus of elasticity and flexural stress shall be measured for gravity and pressure pipe applications in accordance with ASTM D790 and should meet the short term flexural modulus and flexural strength values used in the thickness designs of the CIPP previously submitted.
2. Wall thickness at any point shall not be less than 87.5% of the design thickness.

- 15. RESTORATION:** After completion of lining, all material not used therein shall be removed and disposed of by the Contractor in such a manner and at such point or points he may select, subject to the approval of the District. All roads, sidewalks, and other places on line of work shall be left free, clean and in good order. All removal and cleaning up shall be done by the Contractor without extra compensation, and, if he fails to do such work within a reasonable time, after receipt of notice, the work will be performed by the District, and the cost deducted out of monies due or to become due the Contractor.

All restoration shall be included in the Contractor's unit and/or lump sum prices bid. All cultivated areas, either landscaping, natural vegetation areas, fences and other surface improvements which are damaged by actions of the Contractor, shall be restored as nearly as possible to their original condition with no extra costs to the Owner. Damage to property outside of specified construction limits shall be the responsibility of the Contractor and restoration of same shall be made at the Contractor's expense.

16. WARRANTY AND QUALITY ASSURANCE:

- 16.1 The Contractor shall provide a warranty to be in force and effect for a period of two (2) years from the date of acceptance. The warranty shall cause the Contractor to repair or remove and replace the liner should failure result from faulty materials or installation.
- 16.2 Correction of failed liner or liner deemed unacceptable, as a result of the post video inspection and/or test reports for structural values, thickness, chemical resistance, etc., shall always be the responsibility of the Contractor, at no extra cost to the Owner. Method of correction/repair shall be approved by the Owner with prior field demonstration, if required. It shall be understood that minimum criteria of the specification shall not be lowered to compromise with lower than the required test values, unless approved in writing
- 16.3 The finished liner shall be continuous over the entire length of run between two manholes and shall be free from visual defects such as foreign inclusions, dry spots, pinholes, and delamination. The finished liner shall meet or exceed the requirements of Section 7, Finished and Cured Liner Properties.
- 16.4 Wrinkles in the finished liner pipe which exceed 5% of the pipe diameter are unacceptable. Contractor shall remove either the liner or the wrinkled segments which exceed 5% of the pipe diameter. Additionally, any wrinkles that traverse the invert and impede flow shall be removed. Repair of the removed sections shall be proposed by the Contractor and approved by the Engineer.

17. MEASUREMENT AND PAYMENT:

- 17.1 Measurement - Pipe Length: Sewer pipe shall be measured as specified herein. The lengths of the sewer pipe to be paid for by the lineal foot shall be the horizontal length designated by the Engineer. The length shall be measured from center of manhole to center of manhole and through casings. No deductions will be made from horizontal length for manholes or lateral fittings.
- 17.2 Payment: Items of work, measured as provided above will be paid for at the contract prices per linear foot for the various sizes and types of sewer pipe. The prices paid per linear foot for the various sizes and type of sewer pipe shall be considered full compensation for all pipe, structure excavation, structure backfill, all trench dewatering, and for all temporary resurfacing of trench and all other incidentals required to construct all pipe systems complete in place and no further compensation will be allowed therefore. No measurement will be made or included for surplus pipe (wastage) remaining because of Contractors need to cut standard lengths to fit field conditions.

PART V

DRAWINGS

STEGE SANITARY DISTRICT
PROJECT NO. 12201
JULY 2012

(This page left blank intentionally)

REPRESENTATIVE RIGHT-OF-WAY & EASEMENT SECTION
SEE SPECIAL CONDITIONS, SECTION 1 FOR DESCRIPTION

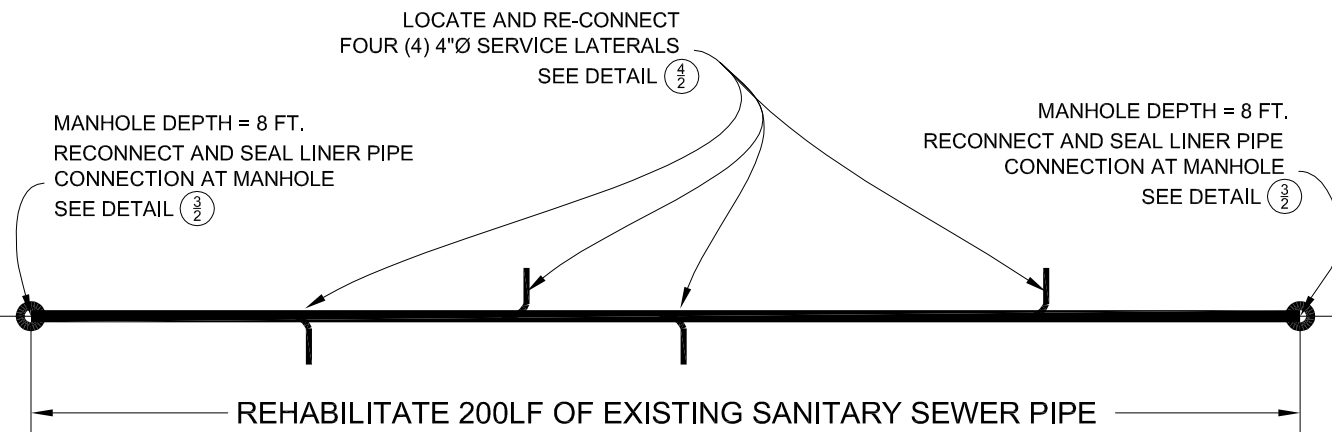

REPRESENTATIVE SANITARY SEWER PIPE SECTION
*** FOR BIDDING PURPOSES ONLY ***

GENERAL NOTES

- The following notes are established merely to guide the contractor as to the general items of work involved and are not intended to cover the complete scope of work. The contractor shall complete all work as per construction documents and specifications.
- The work is being conducted within the jurisdiction of the following permitting authorities:
 - City of El Cerrito
 - City of Richmond
 - Contra Costa County
- All work shall be performed in accordance with the provisions and requirements of the appropriate encroachment and/or construction permit. The contractor is required to obtain permits as required.
- Contractor shall provide a detailed traffic control plan, including schedule, for any portion of the work that requires closure of any part of a street to traffic. The traffic control plan shall be submitted to the respective permitting authority for review and approval prior to the start of work.
- Attention is directed to verifications of depths and exact locations of existing services whether shown on the plan or not and the contractor shall take precautionary measures to preserve and avoid damages to existing utilities encountered. Contractor shall notify PG&E, Pac-Bell, East Bay Municipal Utility District, cable television companies, and Underground Service Alert (USA) for field markings prior to construction. Overhead utility wires exist throughout the project. Extreme caution should be taken when working around these overhead utility wires.
- Contractor must maintain existing flows at all times during construction. Contractor shall notify homeowners of any interruption to sewer services prior to any work on existing sewer pipes. Sewage flows shall be maintained by pumping or temporary cross connection from existing main to new main.

SCALE: NTS

DETAIL 1

REPRESENTATIVE SANITARY SEWER PIPE SECTION

PAVEMENT TO BE RESURFACED IN ACCORDANCE TO THE PROVISIONS AND REQUIREMENTS OF THE ENCROACHMENT PERMIT.

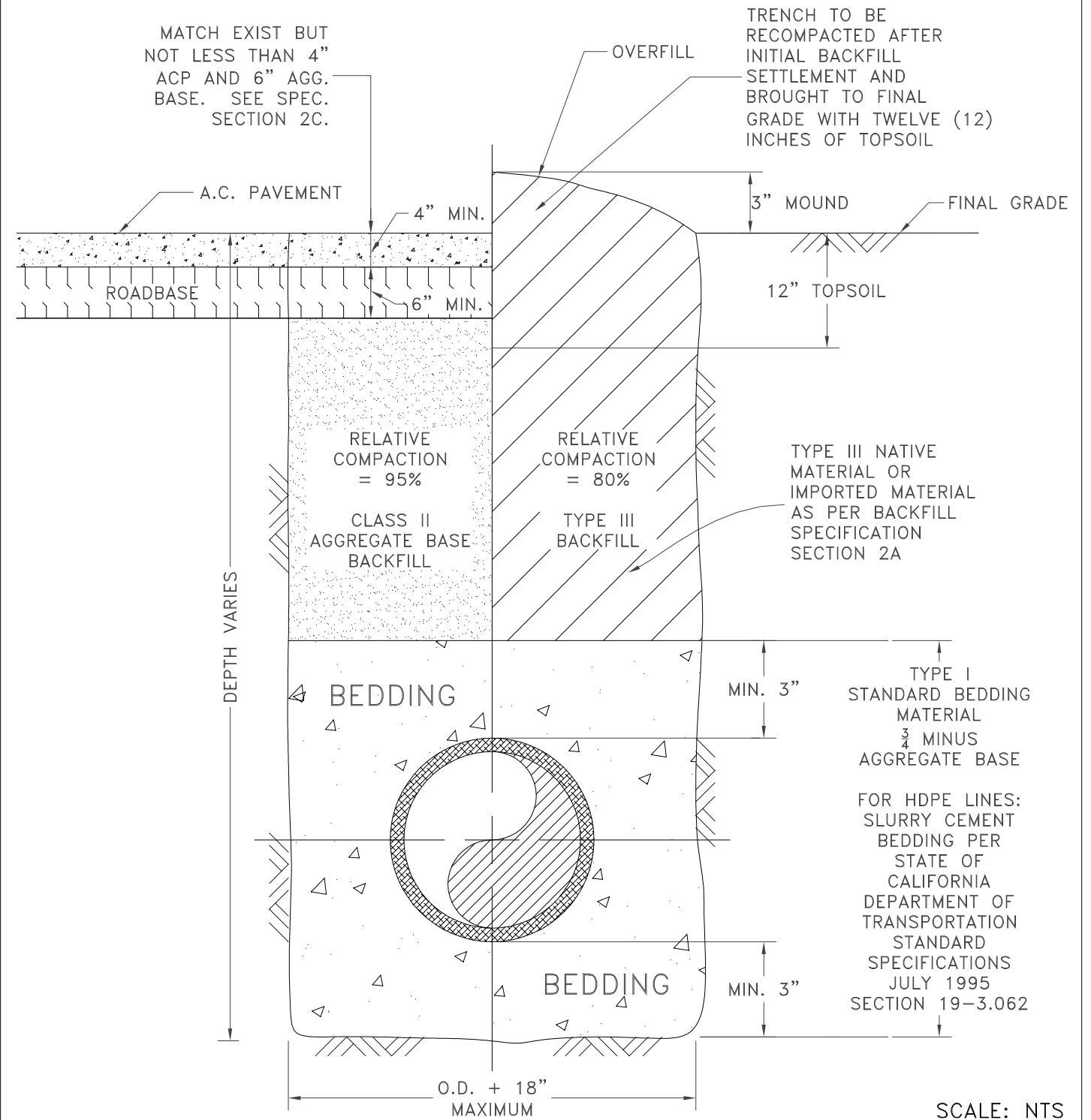

SCALE: NTS

DETAIL 2

BEDDING AND BACKFILL



PROJECT NO. 12201

RAD

Rex Delizo, P.E. C60427

Standard Sewer Rehabilitation Project

Representative Sanitary Sewer Pipe Section +
Bedding and Backfill

DATE	REVISIONS	BY



STEGE SANITARY DISTRICT

7500 Schmidt Lane, El Cerrito, CA 94530-0537

TEL (510) 524-4668 FAX (510) 524-4697

NAME

A

SHEET

1 of 4

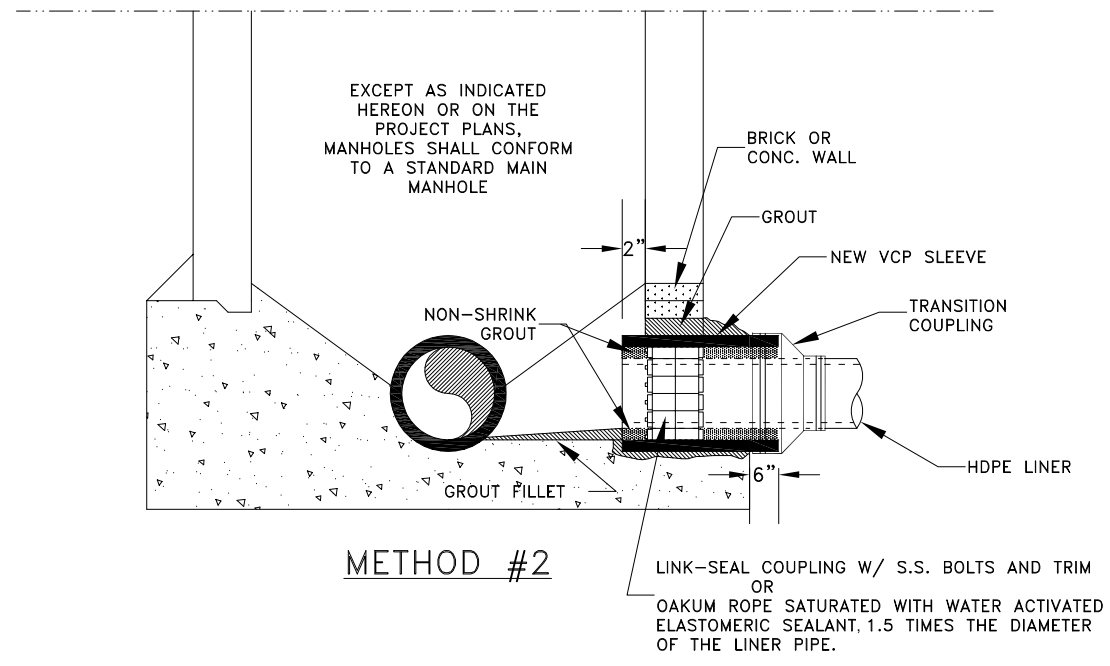
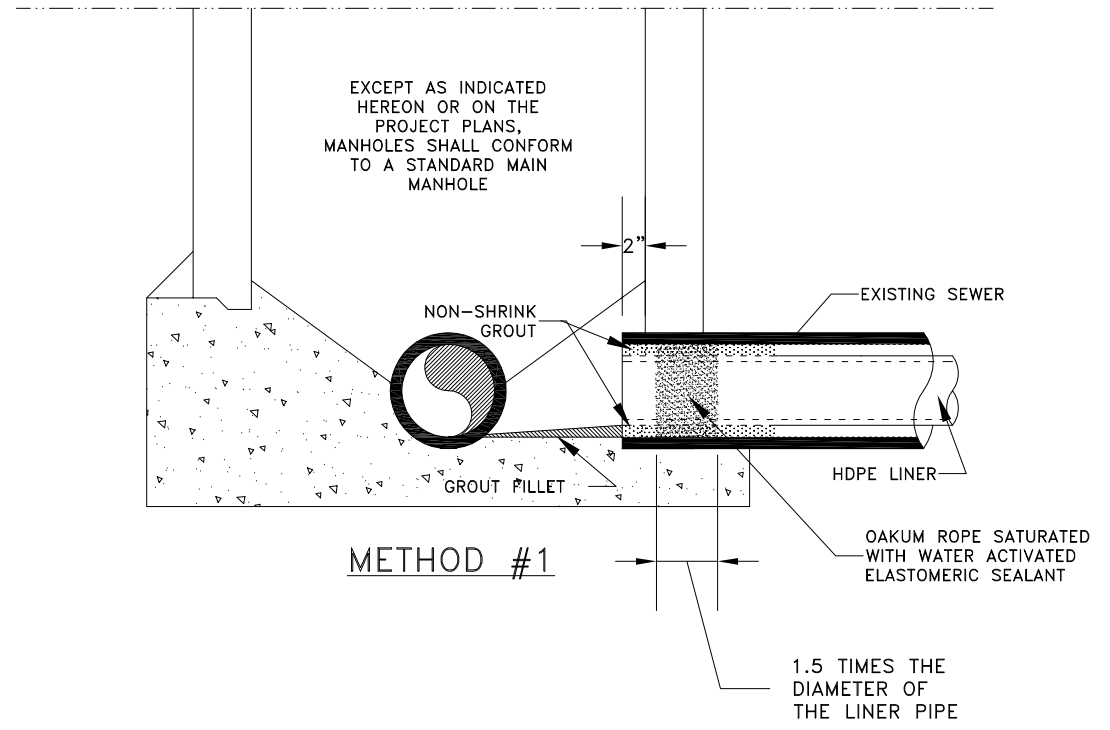

SCALE: NTS

DETAIL 3
MANHOLE CONNECTIONS FOR HDPE LINER PIPE

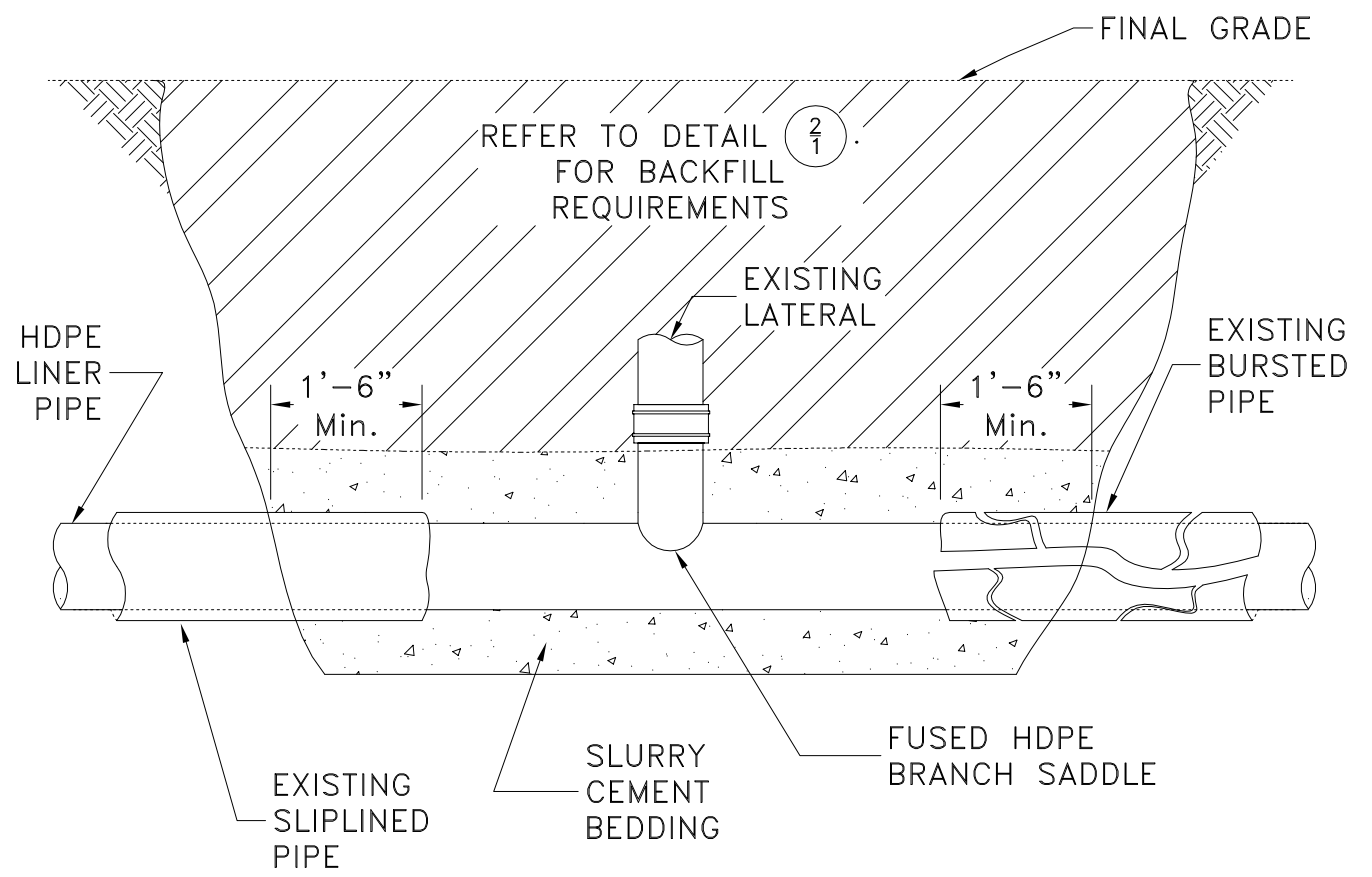

SCALE: NTS

DETAIL 4
LATERAL RECONNECTION FOR HDPE LINER PIPE



PROJECT NO. 12201

RAD

Rex Delizo, P.E. C60427

Standard Sewer Rehabilitation Project

Manhole Connections +
Lateral Reconnection for HDPE Pipe

DATE	REVISIONS	BY



STEGE SANITARY DISTRICT
7500 Schmidt Lane, El Cerrito, CA 94530-0537
TEL (510) 524-4668 FAX (510) 524-4697

NAME
B

SHEET
2 of 4

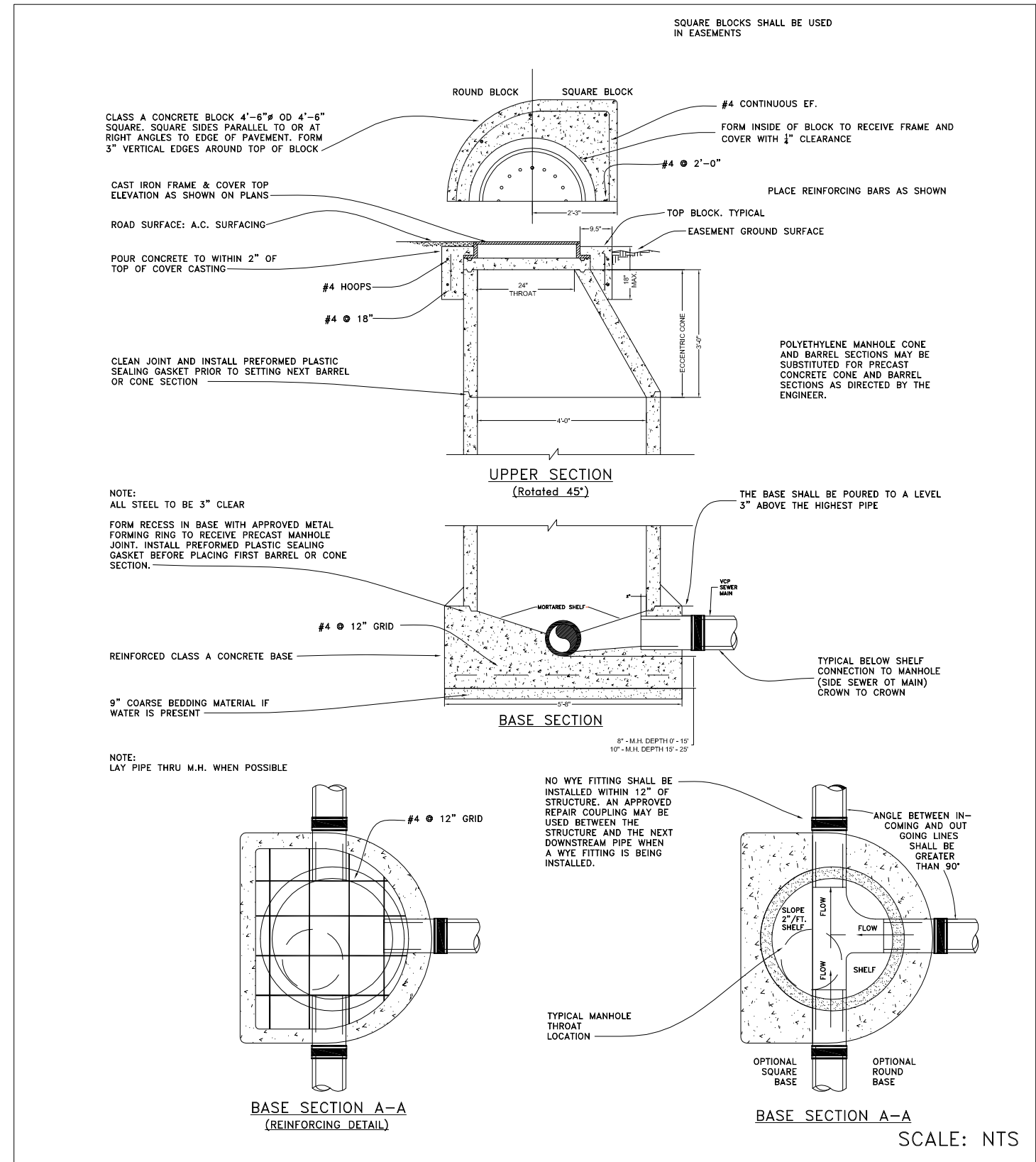

DETAIL 5
STANDARD MAIN MANHOLE STRUCTURE

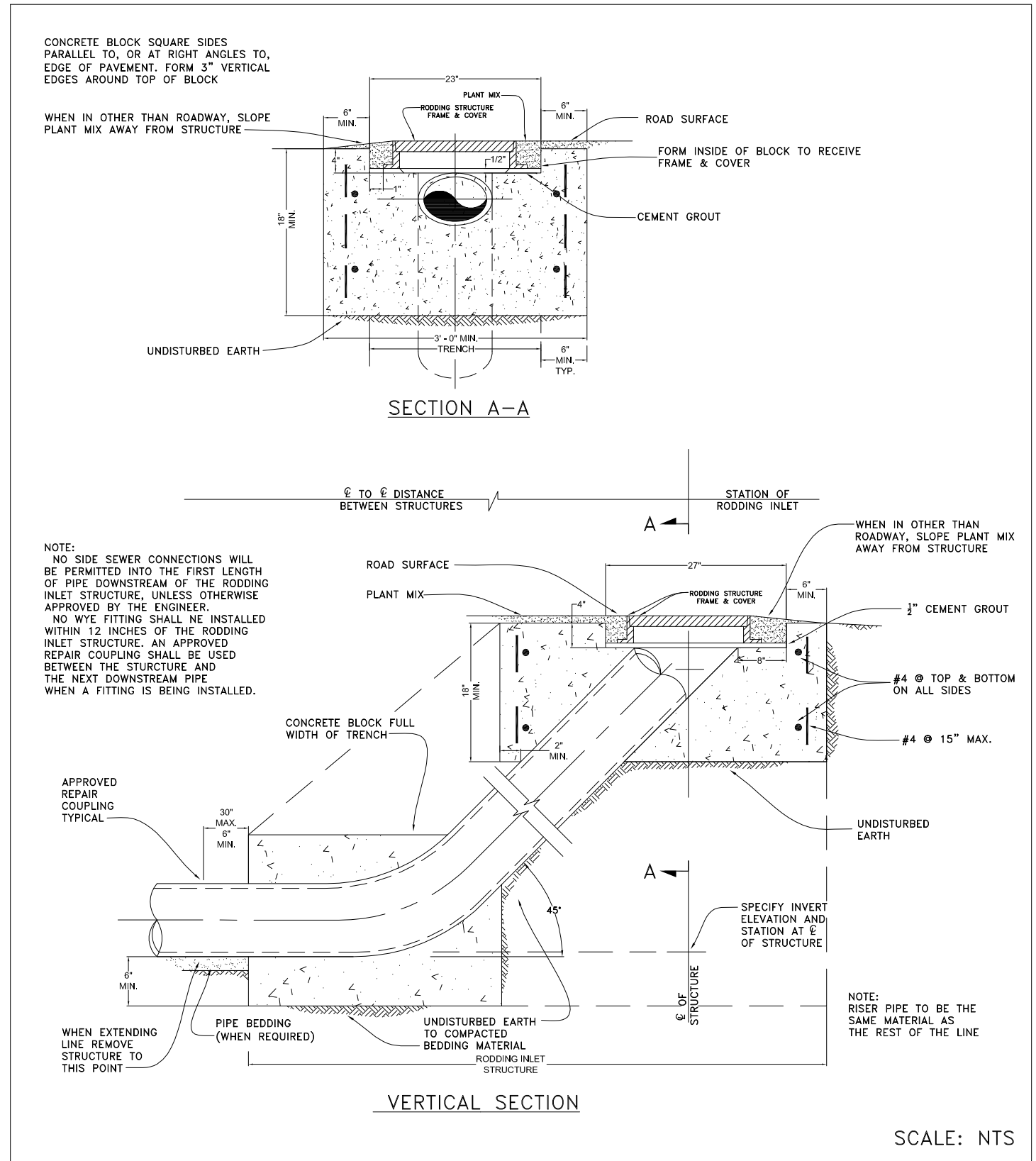

DETAIL 6
RODDING INLET STRUCTURE



PROJECT NO. 12201

RAD

Rex Delizo, P.E. C60427

Standard Sewer Rehabilitation Project

Standard Main Manhole Structure +
Rodding Inlet Structure

DATE	REVISIONS	BY



STEGER SANITARY DISTRICT

7500 Schmidt Lane, El Cerrito, CA 94530-0537

TEL (510) 524-4668 FAX (510) 524-4697

NAME

C

SHEET

3 of 4

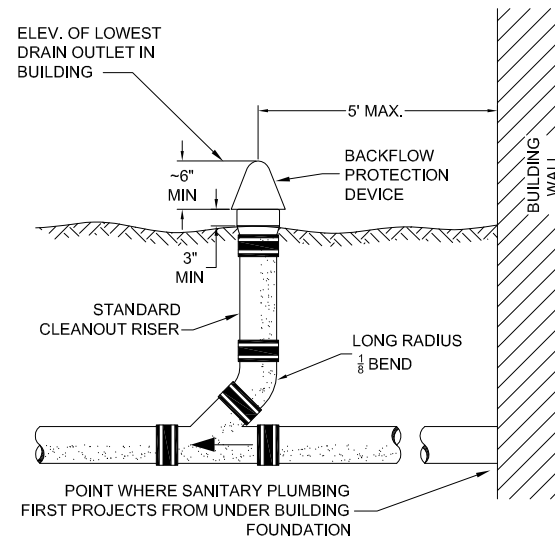

**BACKFLOW PROTECTION DEVICE/
OVERFLOW SYSTEM
TYPE 1**

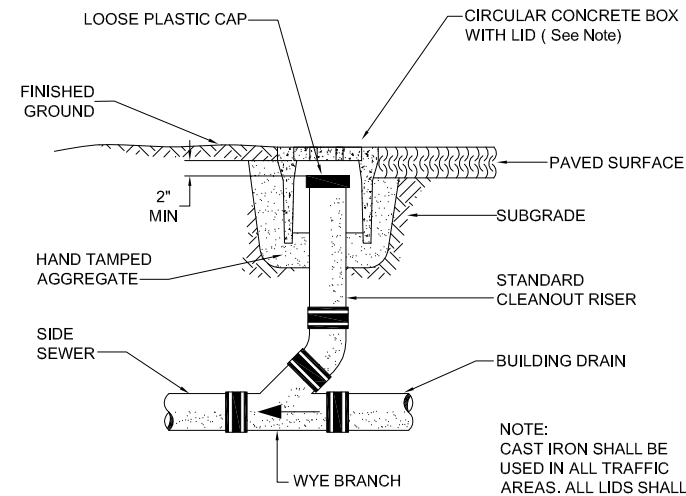

**BACKFLOW PROTECTION DEVICE/
OVERFLOW SYSTEM
TYPE 2**

NOTE:
CAST IRON SHALL BE
USED IN ALL TRAFFIC
AREAS. ALL LIDS SHALL
BE MARKED WITH
AN "S" OR "SEWER"

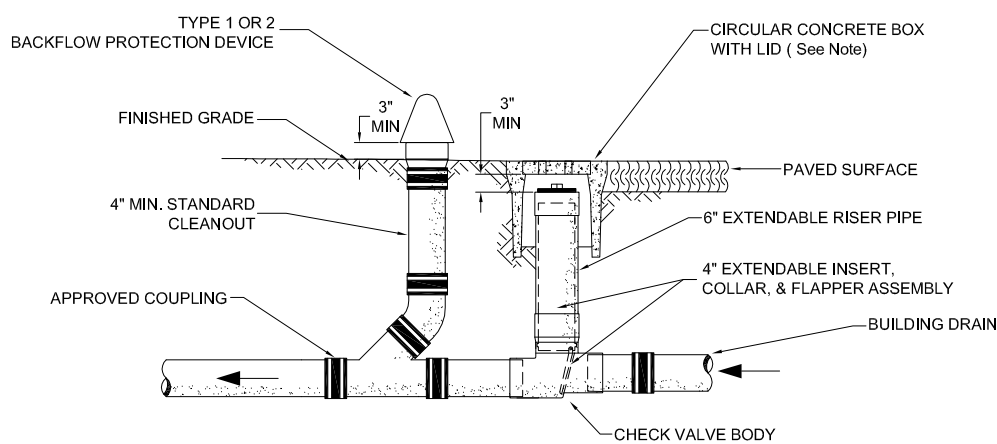

**EXTENDABLE BACKWATER CHECK VALVE
BACKFLOW PROTECTION DEVICE / OVERFLOW SYSTEM
TYPE 3**

NOTES:

ALL CLEANOUTS AND BACKFLOW DEVICES ARE TO BE MAINTAINED BY THE PROPERTY OWNER.

BACKFLOW PROTECTION SYSTEM - TYPE 1 OR 2 SHALL BE INSTALLED IN SEWERS WHERE THE LOWEST DRAIN OUTLET TO BE CONNECTED TO THE MAIN SEWER IS BELOW A POINT 12-INCHES ABOVE THE SURFACE OF THE NEAREST UPSTREAM SEWER STRUCTURE AND IN ALL NEW BUILDINGS.

BACKFLOW CHECK VALVE - TYPE 3 SHALL BE INSTALLED IN SEWERS SERVING BUILDINGS WHERE A BACKFLOW PROTECTION SYSTEM IS REQUIRED AND WHERE SEWAGE CANNOT OVERFLOW TO AN ADJACENT AREA WITHOUT SERIOUS DAMAGE.
(Backwater Valve by Clean Check, Inc. Or Approved Equal)

SCALE: NTS

**DETAIL 7
CLEANOUT WITH BACKFLOW PREVENTION DEVICE**

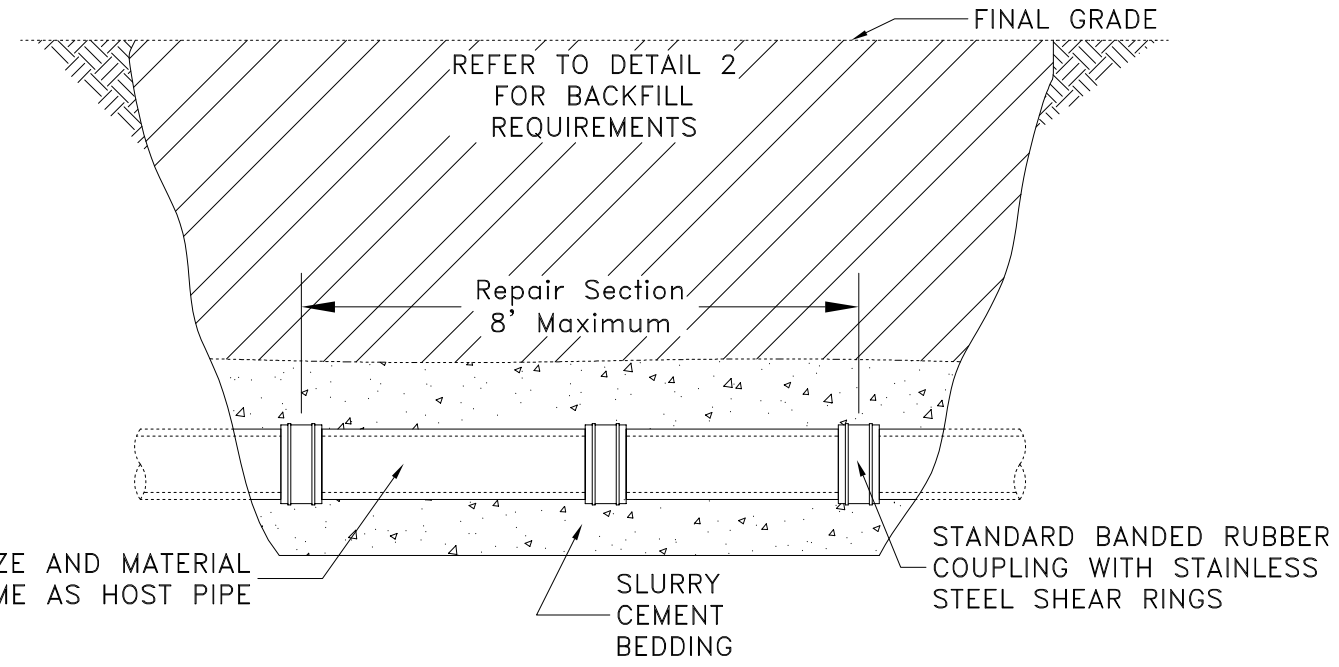

SCALE: NTS

**DETAIL 8
POINT REPAIR**



PROJECT NO. 12201
RAD
Rex Delizo, P.E. C60427

Standard Sewer Rehabilitation Project
Cleanout with Backflow Prevention Device +
Point Repair

DATE	REVISIONS	BY



STEGE SANITARY DISTRICT
7500 Schmidt Lane, El Cerrito, CA 94530-0537
TEL (510) 524-4668 FAX (510) 524-4697

NAME
D
SHEET
4 of 4